

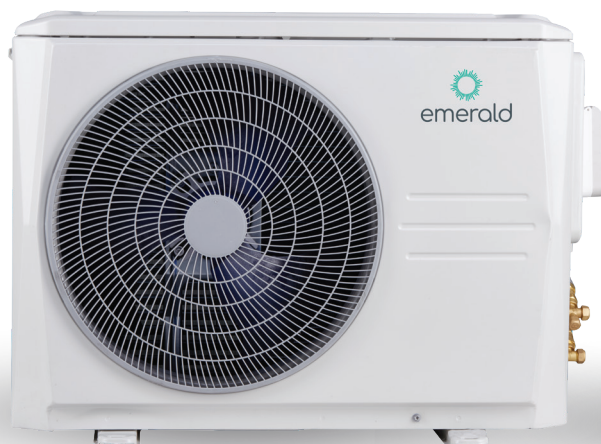

# User guide and installation manual

## Hot Water Heat Pump Split System

HPR200/-1 HPR300/-1  
HPR200E/-1 HPR300E/-1



### IMPORTANT NOTICE

Please read this manual before installing the product and retain for future use. Not following the instructions may result in the product not functioning as intended.

## Installer information

Installer company:

---

Contact number:

---

Installer full name:

---

Install date:

# Contents

<b>Welcome</b>	<b>4</b>
<b>Warranty</b>	<b>4</b>
<b>Important tips</b>	
Air flow	5
Cleaning	5
Servicing	5
<b>Safety precautions</b>	<b>6</b>
<b>Operation instructions</b>	
Control panel	13
Display	13
Keyboard	14
Operating	14
<b>General introduction</b>	
Outdoor unit	32
Water tank	32
Specifications	33
<b>Before installation</b>	
Accessories	35
Space	35
<b>Installation</b>	
Dimension and mounting	37
Drain hole position	38
Pipe connection	39
Quick connect couplings	41
<b>Electrical connection</b>	
Power supply cords	42
Water tank temperature sensor installation	43
Outdoor unit & AUX. power connection	43
Dip switch settings	44
<b>Check</b>	
Quality inspection of electric auxiliary heater	45
System parameters check	45
<b>Error and other code explanation</b>	<b>46</b>
<b>Operations</b>	<b>47</b>
Service and maintenance	48
Confirmation before running	50
Troubleshooting when abnormal situation happens	50
After-sale service	51
Important information for the used refrigerant	51
Water quality limitations	51
About maintenance	51

**Important notice:** Please read and keep this manual carefully before installing this product. Failure to do so may result in the product not working according to its design.

# Welcome to your Emerald hot water heat pump

The Emerald heat pump and Emerald App offer advanced hot water heating.

Engineered to minimise its environmental impact, your Emerald heat pump utilises R290, a natural and non-toxic refrigerant with minimal environmental harm. R290 has zero Ozone Depletion Potential (ODP) and an extremely low Global Warming Potential (GWP) of 3.

Emerald hot water heat pump's can save up to 75% on your hot water costs while enjoying efficient and eco-friendly hot water heating.

Unlike standard electric water heaters, Emerald heat pumps leverage advanced technology to extract heat from the air, delivering exceptional energy and cost savings.

## Registering your warranty gives you more from Emerald

- Priority customer support.
- Tips and advice to maximise savings with your Emerald heat pump.
- Exclusive product updates and promotions.
- Peace of mind knowing your hot water heat pump is protected.

Visit [emerald.com.au/warranty](https://emerald.com.au/warranty) and follow the instructions to complete the warranty registration.

Register now

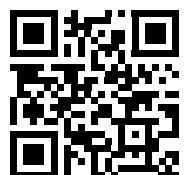

# Important things to remember

There are a few key points to remember to help keep your heat pump running smoothly.

## Allow your heat pump to breathe.

Your heat pump needs air to work properly and heat your hot water. If you block or restrict the air around your heat pump, it won't work as well.

Please don't put items next to your heat pump that can get in the way of the air it needs.

## A routine clean for your heat pump.

For the best performance of your heat pump, we suggest regular cleaning to prevent the accumulation of dirt and leaves that could impact its operation.

## Servicing your heat pump.

For best efficiency, we recommend servicing your heat pump. As with other electrical appliances servicing can identify and resolve issues that could affect your heating system.

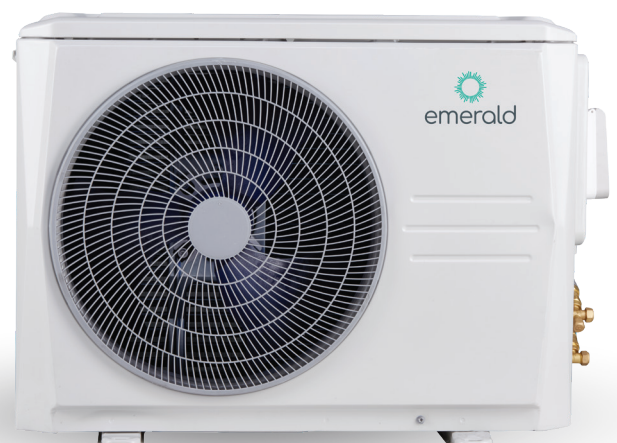

# Safety precautions

Observe the basic safety regulations before starting work and operation.



Hazard which can result in severe personal injury or death.



Hazard or an unsafe practice which may result in severe personal injury or death.

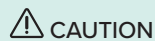

Hazard or an unsafe practice which may result in personal injury, product or property damage.

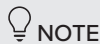

Additional information.

## Symbols on the unit

	<b>WARNING</b>	Indicates this appliance uses a flammable refrigerant. If the refrigerant is leaked and exposed to an external ignition source, there is a risk of fire.
	<b>CAUTION</b>	Indicates the operation manual should be read carefully.
	<b>CAUTION</b>	Indicates a service personnel should be handling this equipment with reference to the installation manual.
	<b>CAUTION</b>	Indicates information is available such as the operating manual or installation manual.

## Target group



These instructions are for qualified contractors and authorised installers only.

- Work on refrigerant circuits with flammable refrigerant (A3) may only be performed by authorised heating contractors trained to EN 378 Part 4 or IEC 60335-2-40, Section HH, with an industry-recognised certificate of competence.
- Brazing or soldering on the refrigerant circuit must only be done by personnel certified to ISO 13585 and AD 2000 HP 100R. Accumulator connections require certification of both personnel and processes by a notified body under the Pressure Equipment Directive (2014/68/EU).
- Electrical work must only be carried out by a qualified electrician.

- Before commissioning, all safety checks must be completed by certified heating contractors. Commissioning must be performed by the installer or an authorised qualified person.

## Intended use

Improper or unintended use may cause injury or death, or damage to the product and property.

This product is the outdoor unit of an air-to-water monoblock heat pump. It uses outdoor air as a heat source for residential heating and domestic hot water.

The exhaust air must flow out freely and not be used for other purposes.

The unit is for outdoor installation only and intended for domestic use.

### Do not install the unit in the following locations:

- Areas with oil mist, spray, or vapours (may damage plastics and cause leaks).
- Areas with corrosive gases (e.g. sulphurous acid gas) which can corrode pipes and joints.
- Near machinery emitting strong electromagnetic waves (may cause malfunction).
- Areas with flammable gases, carbon fiber dust, volatile vapours (e.g. thinners, petrol).
- Locations with high salt content in the air (e.g. near the ocean).
- Sites with unstable voltage (e.g. factories).
- Vehicles or vessels.
- Areas with acidic or alkaline vapours.

### Intended use includes:

- Following the operating instructions for the product and any installation components.
- Complying with all inspection and maintenance requirements in the instructions.
- Installing and setting up the product in line with product and system approvals.
- Ensuring installation, commissioning, inspection, maintenance and troubleshooting are performed only by qualified contractors or authorised installers.
- Installation in accordance with the IP code.

This appliance may be used by children aged 8 years and older, and by persons with reduced physical, sensory or mental capability, or limited experience and knowledge, if they have received supervision or instruction to use it safely and understand the hazards.

- Children must not play with the appliance.
- Cleaning and maintenance must not be carried out by children without supervision.

Any use not specified in these instructions, or use beyond what is described, is considered improper. Direct commercial or industrial use is also deemed improper.

# Safety precautions

## CAUTION

- Any improper use is prohibited.
- Do not rinse the unit.
- Do not place objects or equipment on the top plate.
- Do not climb, sit, or stand on the unit.

### Regulations to be observed

1. National installation regulations.
2. Statutory accident-prevention regulations.
3. Statutory environmental protection regulations.
4. Pressure Equipment Directive 2014/68/EU.
5. Codes of practice from relevant trade associations.
6. Country-specific safety regulations.
7. Regulations and guidelines for operation, servicing, maintenance, repair and safety of cooling, air conditioning and heat pump systems containing flammable or explosive refrigerant.

### Safety instructions for working on the system

The outdoor unit contains flammable refrigerant R290 (propane, C<sub>3</sub>H<sub>8</sub>). If a leak occurs, the escaping refrigerant may create a flammable or explosive atmosphere in the surrounding air.

A safety zone is defined around the outdoor unit. Special rules apply when working within this zone. See section "Safety zone" for details.

### Working in the safety zone

## DANGER

Risk of explosion: A refrigerant leak may create a flammable or explosive atmosphere.

To prevent fire or explosion in the safety zone:

- Keep all ignition sources away, including naked flames, plug sockets, hot surfaces, light switches, lamps, non-protected electrical devices, and mobile devices with batteries (e.g. phones, watches).
- Do not use sprays or combustible gases in the safety zone.

## CAUTION

Only use tools approved for work in the safety zone. Tools must be explosion-protected and comply with standards for refrigerants in safety groups A2L and A3. Suitable tools include brushless machines (e.g. cordless cutters, installation aids, screwdrivers), extraction equipment, vacuum pumps, conductive hoses, and non-sparking mechanical tools.

## CAUTION

- Tools must be suitable for the pressure range in use and maintained in perfect condition.
- Electrical equipment must comply with Zone 2 explosion-risk requirements.
- Do not use flammable materials such as sprays or gases.
- Before starting work, discharge static electricity by touching earthed objects (e.g. heating or water pipes).
- Do not remove, block, or bypass safety devices.
- Do not modify the outdoor unit, pipework, electrical cables, or surroundings. Do not remove components or seals.

### Working on the system

Switch off the power supply to the unit (and all connected parts) at a separate fuse or mains isolator. Confirm the system is no longer live before starting work.

## CAUTION

In addition to the control circuit there may be several power circuits.

## DANGER

Contact with live components can cause severe injury. Some PCB components remain live even after power is switched off.

- Wait at least 4 minutes after isolating power before removing covers, to allow voltage to fully discharge.
- Secure the system against reconnection.
- Always wear appropriate personal protective equipment.
- Never touch switches or electrical parts with wet hands or fingers, as this may cause electric shock and damage the system.

# Safety precautions

## DANGER

Hot surfaces and fluids can cause burns or scalds; cold surfaces may cause frostbite.

- Before servicing or maintenance, switch off the system and allow it to cool or warm to a safe temperature.
- Do not touch hot or cold surfaces on the unit, fittings, or pipe-work.

## NOTE

Electronic components may be damaged by electrostatic discharge. Before starting work, discharge static by touching an earthed object (e.g. heating or water pipes).

## Safety work area and temporary flammability zones

### CAUTION

When working with flammable refrigerants, treat certain areas as temporary flammable zones. These are locations where refrigerant may be released during normal procedures such as recovery, charging, or evacuation, particularly at hose connections.

Maintain a 3-metre safety zone around the unit to reduce risk in case of accidental refrigerant release.

## Working on the refrigerant circuit

R290 refrigerant (propane) is an air-displacing, colourless, flammable, odourless gas that forms explosive mixtures with air. Any refrigerant removed must be disposed of by authorised contractors.

Before starting work on the refrigerant circuit:

- Check the circuit for leaks.
- Ensure strong ventilation, especially at floor level, and maintain it for the duration of the work.
- Secure the work area.
- Inform maintenance staff and anyone nearby of the work being carried out.
- Inspect the immediate area for ignition sources or flammable materials and remove them.
- Use an explosion-proof R290-suitable refrigerant detector (sealed, non-sparking) before, during and after the work.
- Keep a CO<sub>2</sub> or powder fire extinguisher available if refrigerant is being drained, topped up, or if soldering/welding is in progress.
- Display “No Smoking” signs.

## DANGER

Escaping refrigerant can cause fire or explosion, leading to serious injury or death.

- Never drill or apply heat to a charged refrigerant circuit.
- Do not operate Schrader valves unless a fill valve or extraction equipment is connected.
- Prevent electrostatic charge.
- No smoking, naked flames, or sparks. Do not switch lights or electrical appliances on/off in such environments.
- Label all components that contain or have contained refrigerant, and store them in well-ventilated areas as required by regulations and standards.

## DANGER

Direct contact with liquid or gaseous refrigerant can cause frostbite, burns, or other serious injury. Inhalation may cause asphyxiation.

- Avoid direct contact with refrigerant.
- Always wear personal protective equipment when handling refrigerant.
- Never inhale refrigerant vapour.

## DANGER

Refrigerant is under pressure. Mechanical stress on lines or components may cause leaks.

- Do not apply loads to refrigerant lines or components (e.g. by supporting or placing tools on them).

## DANGER

Hot or cold metal surfaces on the refrigerant circuit can cause burns or frostbite on contact. Always wear personal protective equipment.

## NOTE

Hydraulic components may freeze during refrigerant removal. Drain heating water from the heat pump beforehand.

## DANGER

Damage to the refrigerant circuit may allow refrigerant to enter the hydraulic system.

- After completing work, vent the hydraulic system correctly.
- Ensure the area is well ventilated during venting.

# Safety precautions

## Installation – General

- Use only specified accessories and parts. Using non-approved parts may cause leaks, electric shock, fire, or the unit falling.
- Install on a foundation strong enough to support the unit's weight. An inadequate base may cause the unit to fall and cause injury.
- Ensure installation accounts for strong winds, cyclones, or earthquakes. Incorrect installation may lead to accidents.
- Earth the unit and install a residual current device (RCD) in accordance with local regulations. Operating without proper earthing or RCD protection may cause electric shock or fire.
- Install the power cable at least 1 metre from televisions or radios to reduce interference (greater distances may be required depending on signal strength).
- Damaged power cords must only be replaced by the manufacturer, its service agent, or a suitably qualified person.

### CAUTION

- Do not install an air vent valve on the indoor side. Ensure the indoor safety valve outlet is directed outdoors.
- Keep ignition sources away from the air vent valve and safety valve outlet.
- For outdoor installations, consider two cases to prevent system damage, refrigerant release, or other risks:
  1. Equipment in areas accessible to the public.
  2. Equipment in restricted areas with access only for authorised persons.

### DANGER



Open flames, fires, open ignition sources and smoking are prohibited.

### DANGER



Flammable materials are strictly prohibited.

## Freezing protection

### CAUTION

Freezing may damage the heat pump.

- Insulate all hydraulic lines.
- Fill the secondary circuit with antifreeze in accordance with local regulations and standards.

## Connecting cables

### DANGER

- If electrical cables are too short, leaked refrigerant gas may enter the building.
- The minimum length of connecting cables between the indoor and outdoor unit is 3 metres.

## Repair work

### CAUTION

- Repairing safety-related components may compromise system safety.
- Replace faulty parts only with genuine manufacturer spares.
- Do not attempt to repair the inverter; replace it if defective.
- Do not carry out repairs in the field. Repairs must be performed at a designated service location.

## Auxiliary components, spare and replacement parts

### CAUTION

- Using spare or wearing parts not tested with the system may impair its function.
- Installing unauthorised components or making unapproved modifications can compromise safety and void the warranty.
- Only use original spare parts supplied or approved by the manufacturer.

## Safety instructions for operating the system In case of refrigerant leak

### WARNING

Always keep at least 2 metres away from the unit, regardless of whether it is operating. Children must be kept clear at all times.

# Safety precautions

## DANGER

A refrigerant leak can cause fire, explosion, or asphyxiation, leading to serious injury or death.

- Ensure strong ventilation, especially at floor level near the outdoor unit.
- No smoking, naked flames, or sparks. Do not switch lights or electrical appliances on/off in such areas.
- Evacuate all people from the danger zone.
- From a safe position, switch off power to all system components.
- Remove all ignition sources from the danger zone.
- The system user must ensure no ignition source is introduced during repair.
- Repairs must only be performed by an authorised contractor.
- Do not recommission the system until repairs are complete.

## CAUTION

Direct contact with liquid or gaseous refrigerant may cause frostbite, burns, or other serious injury. Inhalation may cause asphyxiation.

- Avoid direct contact with refrigerant.
- Never breathe in refrigerant vapour.

### What to do if water leaks

## DANGER

Water leakage from the appliance may cause electric shock. Switch off the heating system at the external isolator (e.g. fuse box or distribution board).

## DANGER

Water leakage from the appliance may cause scalding. Never touch hot water.

### What to do if the outdoor unit ices up

## CAUTION

Ice build-up in the condensate pan or fan area can damage the equipment.

- Do not use mechanical tools to remove ice.
- Before using any electric heating device, check the refrigerant circuit for leaks with a suitable detector. The heater must not be an ignition source and must comply with EN 60335-2-30.
- In areas with frequent frost or heavy fog, install a fan ring heater approved for R290 refrigerant and/or an electric ribbon heater in the condensate pan.

### Safety instructions for storage of the outdoor unit

The outdoor unit is charged at the factory with refrigerant R290 (propane).

## DANGER

A refrigerant leak can cause fire, explosion, or asphyxiation, leading to serious injury or death.

Storage requirements:

- An explosion-prevention plan must be in place.
- Store only in well-ventilated areas.
- Keep away from ignition sources, heat, and smoking.
- Storage temperature:  $-25\text{ }^{\circ}\text{C}$  to  $70\text{ }^{\circ}\text{C}$ .
- Store only in the original protective packaging.
- Protect the unit from damage.
- The maximum number of units in one location must comply with local conditions.

## CAUTION

Fires involving R290 must only be extinguished with  $\text{CO}_2$  or dry powder extinguishers.

# Safety precautions

## About the refrigerant



Before any repair work on systems containing flammable refrigerant, the following must be observed:

- Work must follow a controlled procedure to minimise the risk of flammable gas or vapour being present.
- Inform all maintenance staff and anyone nearby of the nature of the work. Avoid working in confined spaces.
- Section off the work area and ensure it is free of flammable materials.
- Check the area with a suitable, intrinsically safe refrigerant detector before and during work.
- Use only non-sparking, sealed, or intrinsically safe leak detection equipment approved for flammable refrigerants.
- If hot work is required, have CO<sub>2</sub> or dry powder fire extinguishers at hand.
- Do not use ignition sources near any pipework containing or that has contained flammable refrigerant.
- Keep all ignition sources, including cigarettes, well away from the site during installation, repair, removal, or disposal.
- Display “No Smoking” signs and confirm the area is clear of ignition hazards before starting work.
- Ensure the workspace is outdoors or well ventilated before opening the system or conducting hot work. Maintain ventilation throughout to disperse refrigerant safely.
- Replacement electrical components must be suitable for purpose and comply with specifications.
- Always follow the manufacturer’s maintenance and service instructions. If in doubt, consult the manufacturer’s technical team.

### Checks for installations using flammable refrigerants

- Charge size must be appropriate to the room size where refrigerant-containing components are installed.
- Ventilation systems and outlets must function correctly and remain unobstructed.
- For indirect refrigerating circuits, check the secondary circuit for refrigerant.
- Equipment markings must remain visible and legible; restore any damaged or missing labels.
- Refrigeration pipes and components must be installed where they are not exposed to corrosive substances, unless built from corrosion-resistant materials or adequately protected.

### Repair and maintenance of electrical components

- Carry out initial safety checks and component inspections.
- Do not reconnect power until any safety-related fault is fully rectified. If temporary operation is unavoidable, use an adequate interim solution and report it to the owner.

### Initial safety checks should include:

- Safely discharging capacitors to prevent sparking.
- Ensuring no live components or wiring are exposed during charging, recovery, or purging.
- Verifying continuity of earth bonding.

### Working on sealed components

- Disconnect all power supplies before removing sealed covers or components.
- If power must remain connected during servicing, continuous leak detection must be performed at critical points.

### Precautions for electrical safety

- Do not alter casings in a way that compromises protection (e.g. damaged cables, excess connections, terminals not to spec, seal damage, or incorrect gland fittings).
- Check seals and sealing materials are intact and effective against flammable atmospheres. Replace only with manufacturer-specified parts.
- Do not apply permanent inductive or capacitive loads beyond the equipment’s rated voltage or current.
- Only intrinsically safe components may be worked on live in flammable atmospheres, and test equipment must have the correct rating.

### Component replacement

- Only use parts specified by the manufacturer. Non-approved parts may cause refrigerant ignition in the event of a leak.
- Check all cabling for wear, corrosion, excess pressure, vibration, sharp edges, or other environmental damage. Inspections must consider ageing and vibration from compressors or fans.

### Opening the refrigerant circuit (repairs or other work)

Follow standard procedures, but also apply best practice due to flammability:

1. Recover the refrigerant into approved recovery cylinders.
  2. Purge the circuit with oxygen-free nitrogen (OFN).
  3. Evacuate the system.
  4. Purge again with OFN.
  5. Open the circuit by cutting or brazing.
- The system may need multiple flushes with OFN to ensure safety. Do not use compressed air or oxygen.
  - To flush, break the vacuum with OFN, pressurise to working pressure, vent to atmosphere, then pull down to vacuum. Repeat until no refrigerant remains.
  - For final OFN charge, vent to atmospheric pressure before starting work.
  - This process is essential before any brazing operations.

### Safety measures during repairs

- Ensure the vacuum pump outlet is kept away from ignition sources and the area is well ventilated.
- Prevent cross-contamination of refrigerants when using charging equipment.
- Keep hoses and lines as short as possible to minimise refrigerant volume.
- Pressure test the system with OFN before recharging.

# Safety precautions

## Decommissioning

Before starting:

- The technician must be fully familiar with the equipment.
- Recover all refrigerant safely.
- Take oil and refrigerant samples if analysis may be required for reuse.
- Ensure electrical power is available for the procedure.

Steps:

- a) Review equipment details and operation.
- b) Electrically isolate the system.
- c) Before proceeding, confirm:
  - Mechanical handling equipment is available if required for refrigerant cylinders.
  - All personal protective equipment (PPE) is available and being worn correctly.
  - Recovery must always be supervised by a competent person.
  - Recovery equipment and cylinders must comply with relevant standards.
  - If possible, pump down the refrigerant system. If not, use a manifold to remove refrigerant from multiple parts of the system.
  - Place cylinders on calibrated weighing scales before recovery.
  - Operate the recovery machine in accordance with the manufacturer's instructions.
  - Do not overfill cylinders (maximum 80% liquid charge).
  - Do not exceed the cylinder's maximum working pressure at any time.
  - Once filled, promptly remove cylinders and equipment from site, ensuring all isolation valves are closed.
  - Recovered refrigerant must not be charged into another system unless cleaned and tested.
  - Label equipment as decommissioned and refrigerant emptied. Labels must be dated, signed, and state that the unit contained flammable refrigerant.

## Cylinders and recovery equipment

- Only use designated recovery cylinders for the refrigerant type.
- Cylinders must have pressure relief valves and shut-off valves in good working order.
- Empty recovery cylinders should be evacuated and, where possible, cooled before use.
- Recovery equipment must be in good condition, suitable for flammable refrigerants, and used with instructions at hand.
- Hoses must have leak-free disconnect couplings.
- Ensure recovery equipment is properly maintained, electrical components are sealed, and ignition risk is prevented.
- Use only calibrated weighing scales in good working order.

## Handling and return

- Return recovered refrigerant to the supplier in correct cylinders with a Waste Transfer Note.
- Do not mix refrigerants in recovery equipment or cylinders.
- If removing a compressor or oils, evacuate to safe levels to remove flammable refrigerant from lubricant. This must be

done before returning the compressor to the supplier.

- To accelerate evacuation, heat the compressor body with an electric heater only.
- Oil draining must be performed with safety precautions.

## Warnings

- Disconnect the appliance from the power supply before servicing or replacing parts.
- These are partial unit air conditioners, compliant with international partial unit standards. They must only be connected to other units confirmed as compliant with the same requirements.

## Leak detection

- Never use ignition sources to search for refrigerant leaks. Halide torches or any detector using a naked flame must not be used.

## Approved leak detection methods for flammable refrigerants:

- Use electronic leak detectors suitable for flammable refrigerants. Ensure they are not an ignition source and are calibrated in a refrigerant-free area.
- Detectors should be set at a percentage of the refrigerant's LFL (maximum 25%) and confirmed as suitable for the refrigerant used.
- Leak detection fluids may be used but avoid chlorine-based detergents, as chlorine can react with refrigerant and corrode copper pipes.
- If a leak is suspected, extinguish or remove all naked flames.
- If a leak is confirmed and brazing is required, first recover all refrigerant from the system, or isolate it using shut-off valves away from the leak.
- Purge the system with oxygen-free nitrogen (OFN) before and during brazing.

## Disposal

This equipment contains flammable refrigerant and must be disposed of in accordance with national regulations.

- Do not dispose of this product or electrical appliances as unsorted municipal waste.
- Use designated collection facilities for special treatment and safe disposal.
- Contact your local authority for details of approved collection systems.
- Improper disposal (e.g. landfill or dumping) can release hazardous substances into groundwater and the food chain, causing serious health risks.



# Operation instructions

## Control panel

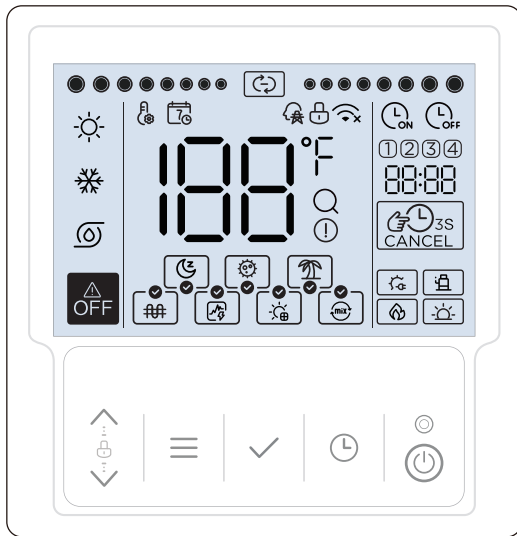

## Display

Icon	Name	Description
	Domestic hot water mode	The indicator will illuminate when the unit is set to Domestic Hot Water (DHW) mode. Otherwise, the indicator will remain off.
	Cooling mode	Not available
	Pump mode	Not available
	Silence function	The indicator will illuminate when the silence function is activated and switch off when it is not. When the function is selected (but not activated), the icon  will flash slowly. If the manual disinfection function is activated, the icon will flash quickly on the main interface.
	Disinfection function	The indicator will illuminate when the disinfection function is activated and switch off when it is not. When the function is selected (but not activated), the icon  will flash slowly. If the manual disinfection function is activated, the icon  will flash quickly on the main interface.
	Holiday away function	The indicator will illuminate when the holiday-away function is activated and switch off when it is not. When the function is selected (but not activated), the icon  will flash slowly.
	Boost function	The indicator will illuminate when the boost function is activated and switch off when it is not. When the function is selected (but not activated), the icon  will flash slowly. If the manual boost function is activated, the icon  will flash quickly on the main interface. If both the disinfection and boost functions are activated, the two icons will be displayed alternately.
	Manual e-heating function	The indicator will illuminate and flash quickly when the manual E-heating function is activated, and switch off when it is not. When the function is selected (but not activated), the icon  will flash slowly.
	OPT.Backup function	The indicator will illuminate when the OPT.Backup function is activated and switch off when it is not. When the function is selected (but not activated), the  icon will flash slowly.
	Solar-energy function	The indicator will illuminate when the solar-energy function is activated and switch off when it is not. When the function is selected (but not activated), the icon  will flash slowly.
	Hybrid function	The indicator will illuminate when the hybrid function is activated and switch off when it is not. When the function is selected (but not activated), the icon  will flash slowly.

## Display panel

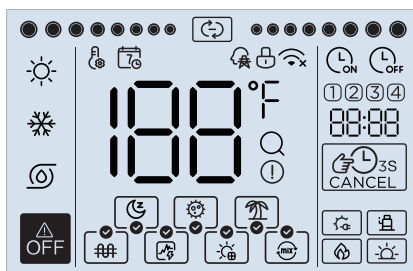

# Operation instructions

## Display (continued)

Icon	Name	Description
	OFF icon	The indicator will illuminate when the user turns off the controller or selects OFF mode through a timer.
	Operating icon	The indicator will illuminate dynamically only when the unit is operating.
	Setting icon	The indicator will illuminate only when settings are being adjusted.
	Weekly-schedule icon	The indicator will illuminate when the weekly schedule is activated in the app and switch off when it is not.
	Smart-grid icon	The indicator will illuminate when the smart-grid function is activated and switch off when it is not.
	Lock icon	The indicator will illuminate only when the keypad is locked.
	Wi-Fi icon	Not available
	Temperature icon	Displays the current tank temperature (in DHW mode) on the main interface, or the set parameters when adjusting settings.
	Temperature-unit icon	Displays °C or °F when the temperature icon  shows the temperature.
	Query icon	The indicator will illuminate only while a query is in progress.
	Alarm icon	Will quickly flash when a fault occurs.
	Boiler icon	When this icon is illuminated, it indicates that the boiler should be switched on.
	Solar icon	The icon will illuminate when a solar energy signal is present.
	E-heater icon	The icon will illuminate when the E-heater is operating.
	Heat-pump icon	The icon will illuminate when the compressor is operating.
	Cancel icon	The icon will illuminate when the timer or buzzer can be cancelled.
	Timer-on icon	The icon will illuminate when a timer has been set.
	Timer-off icon	The icon will illuminate when a timer has been set to switch off.
	Clock icon	Normally displays the clock on the main interface. Displays an error code when a fault occurs. Displays other parameters when querying or adjusting settings.
	Timer icon	The icon will illuminate when the corresponding timer is activated.

## Keyboard

Icon	Name	Description
	Adjustment buttons	For adjusting parameters, moving cursor and so on.
	Menu button	For entering or quit menus, and so on.
	Confirm button	For confirming settings, entering manual functions, and so on.
	Clock/Timer clock button	For setting clock or timer.
	ON/OFF button	For turn on or turn off the unit. If user turn on the unit, the led will be lightened, and the led will be distinguished if user turn off the unit.

## Operation

### Installation settings

There are up to 20 items can be set up. The items include:

- |                     |                                 |
|---------------------|---------------------------------|
| 1 Network (reserve) | 11 Smart grid                   |
| 2 Timer type        | 12 Tank volume                  |
| 3 Temperature unit  | 15 Manually defrost             |
| 4 Silence           | 18 Refrigerant recovery         |
| 5 Disinfection      | 19 Power consumption estimation |
| 6 Holiday away      | 20 Operating time statistics    |
| 7 OPT.Backup        | 24 Unit address (reserve)       |
| 8 Solar energy      | 26 Clock correction             |
| 9 Hybrid            | 27 Validity period setting      |
| 10 Boost            | 28 E-heater reset               |

In these items, only one of 7-OPT.Backup, 8-Solar energy and 11-Smart grid can be set as valid.

Press and hold the ++ buttons for 3 seconds to enter installation settings.

Use the / buttons to switch and select the item number. Press the button to enter the corresponding item setting, or press the button to exit installation settings (any parameters not confirmed will not be saved).

Setting method shown on following pages:

# Operation instructions

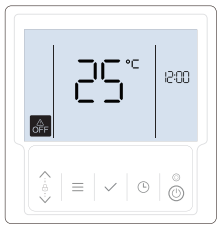

Press and hold  $\wedge + \vee + \odot$  for 3 sec. to enter installation item selection interface, the interface will display item code (number).

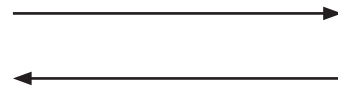

Press  $\equiv$  button to quit the installation setting interface and return to main interface.



Press  $\wedge \vee$  buttons to change different item code (1~28).  
Press  $\checkmark$  button to enter the selected function settings.

## Network setting (reserve)

In the installation item selection interface, press  $\wedge \vee$  buttons to select the item code 1.

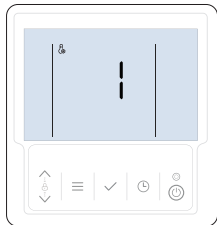

Press  $\checkmark$  button to enter the network function settings.

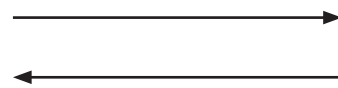

Press  $\equiv$  button to return to item selection interface without saving parameters.



Press  $\wedge \vee$  buttons to set network function on (ON) or off (OFF), and the selected code (ON or OFF) will flash slowly.

If the network function is off, press  $\checkmark$  button to return to installation item selection interface and the network will be set to the local control mode automatically.

If the network function is on, press  $\checkmark$  button to enter the control mode setting interface, then press  $\wedge \vee$  buttons to select network control mode, and the selected code (LC-NC, LC or NC) will flash slowly.

Press  $\checkmark$  button to confirm control mode and return to installation item selection interface.

Press  $\equiv$  button to return to item selection interface without changing the control mode.

The code LC means all control functions are only in controller, and network user can only view the parameters.

The code NC means all control functions are only on network, and the controller will be only used to view the parameters.

The code LC-NC means all control functions can be used in both the controller and network, the unit will execute latest command.

## Timer type setting

In the installation item selection interface, press  $\wedge \vee$  buttons to select the item code 2.

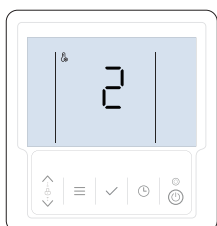

Press  $\checkmark$  button to enter the network function settings.

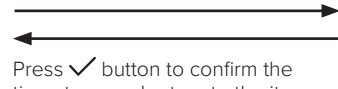

Press  $\checkmark$  button to confirm the timer type and return to the item selection interface.

Press  $\equiv$  button to return to item selection interface and do not change the timer type.

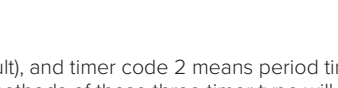

Press  $\wedge \vee$  buttons to set timer type (1~3), and the selected number code will flash slowly.

Timer code 1 means point timer (default), and timer code 2 means period timer, and timer code 3 means appointment timer. The specific differences and setting methods of these three timer type will be explained later.

# Operation instructions

## Temperature unit setting

In the installation item selection interface, press  $\wedge$   $\vee$  buttons to select the item code 3.

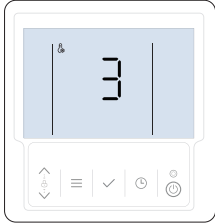

Press  $\checkmark$  button to enter the temperature unit type setting.

Press  $\checkmark$  button to confirm the unit type and return to the item selection interface.

Press  $\equiv$  button to return to item selection interface and do not change the unit type.

Press  $\wedge$   $\vee$  buttons to set temperature unit ( $^{\circ}\text{C}$  or  $^{\circ}\text{F}$ ), and the selected code will flash slowly.

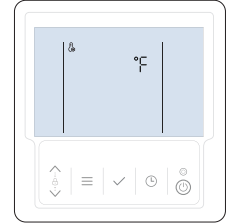
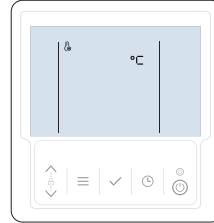

## Silence setting

In the installation item selection interface, press  $\wedge$   $\vee$  buttons to select the item code 4.

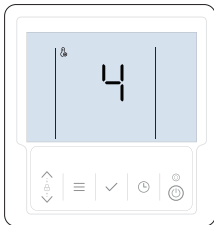

Press  $\checkmark$  button to enter the silence function settings.

Press  $\checkmark$  button to confirm the silence setting and return to the item selection interface.

Press  $\equiv$  button to return to item selection interface and do not change the silence setting.

Press  $\wedge$   $\vee$  buttons to set silence function on (07) or off (0F), and the selected code (07 or 0F) will flash slowly.

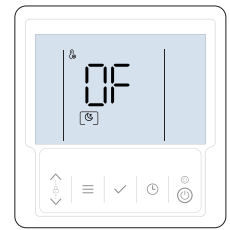
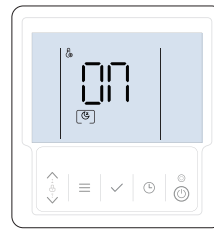

## Disinfection setting

In the installation item selection interface, press  $\wedge$   $\vee$  buttons to select the item code 5.

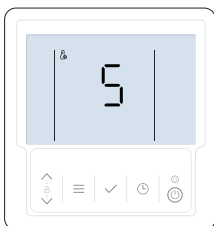

Press  $\checkmark$  button to enter the disinfection function settings.

Press  $\checkmark$  button to confirm the disinfection setting and return to the item selection interface.

Press  $\equiv$  button to return to item selection interface and do not change the disinfection setting.

Press  $\wedge$   $\vee$  buttons to set disinfection function on (07) or off (0F), and the selected code (07 or 0F) will flash slowly.

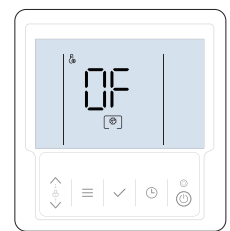
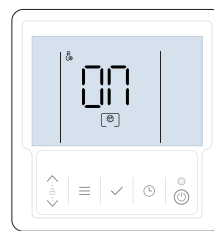

## Holiday away setting

In the installation item selection interface, press  $\wedge$   $\vee$  buttons to select the item code 6.

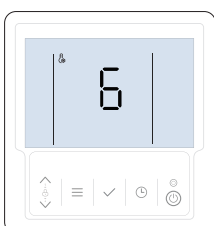

Press  $\checkmark$  button to enter the holiday away function settings.

Press  $\checkmark$  button to confirm the holiday away setting and return to the item selection interface.

Press  $\equiv$  button to return to item selection interface and do not change the holiday setting.

Press  $\wedge$   $\vee$  buttons to set holiday away function on (07) or off (0F), and the selected code (07 or 0F) will flash slowly.

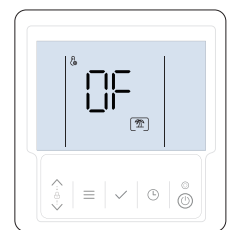
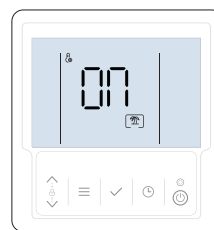

# Operation instructions

## Opt.Backup setting

In the installation item selection interface, press  $\wedge$   $\vee$  buttons to select the item code 7.

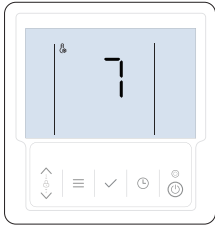

Press  $\checkmark$  button to enter the OPT. Backup setting.

Press  $\checkmark$  button to confirm the OPT.Backup setting and return to the item selection interface.

Press  $\equiv$  button to return to item selection interface and do not change the OPT.Backup.

Press  $\wedge$   $\vee$  buttons to set temperature unit ( $^{\circ}\text{C}$  or  $^{\circ}\text{F}$ ), and the selected code will flash slowly.

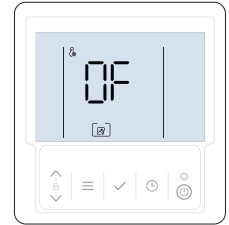
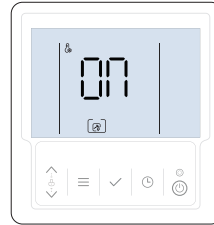

## Solar energy setting

In the installation item selection interface, press  $\wedge$   $\vee$  buttons to select the item code 8.

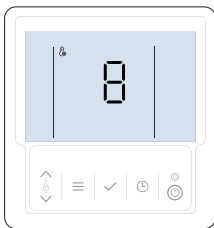

Press  $\checkmark$  button to enter the solar energy function setting.

Press  $\checkmark$  button to confirm the solar energy setting and return to the item selection interface.

Press  $\equiv$  button to return to item selection interface and do not change the solar energy.

Press  $\wedge$   $\vee$  buttons to set silence function on (0N) or off (0F). and the selected code (0N or 0F) will flash slowly.

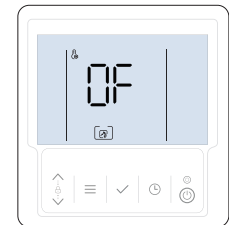
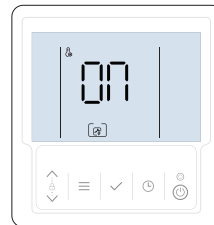

## Hybrid setting

In the installation item selection interface, press  $\wedge$   $\vee$  buttons to select the item code 9.

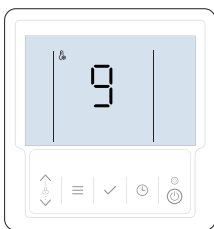

Press  $\checkmark$  button to enter the hybrid function setting.

Press  $\checkmark$  button to confirm the hybrid setting and return to the item selection interface.

Press  $\equiv$  button to return to item selection interface and do not change the hybrid setting.

Press  $\wedge$   $\vee$  buttons to set disinfection function on (0N) or off (0F). and the selected code (0N or 0F) will flash slowly.

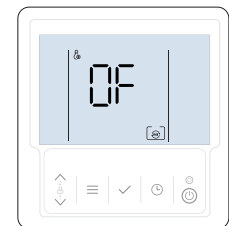
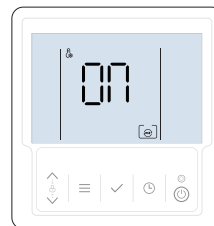

## Boost setting

In the installation item selection interface, press  $\wedge$   $\vee$  buttons to select the item code 10.

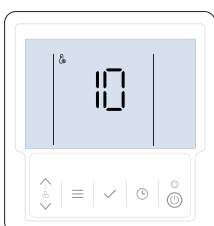

Press  $\checkmark$  button to enter the boost function setting.

Press  $\checkmark$  button to confirm the boost setting and return to the item selection interface.

Press  $\equiv$  button to return to item selection interface and do not change the boost setting.

Press  $\wedge$   $\vee$  buttons to set holiday away function on (0N) or off (0F). and the selected code (0N or 0F) will flash slowly.

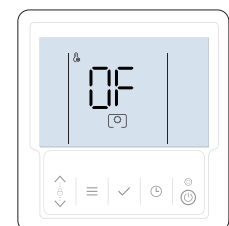
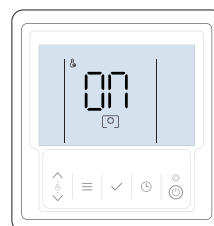

# Operation instructions

## Smart grid setting

In the installation item selection interface, press  $\wedge$   $\vee$  buttons to select the item code 11.

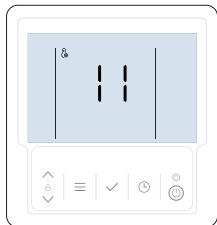

Press  $\checkmark$  button to enter the smart grid setting.

Press  $\checkmark$  button to confirm the smart grid setting and return to the item selection interface.

Press  $\equiv$  button to return to item selection interface and do not change the smart grid.

Press  $\wedge$   $\vee$  buttons to set temperature unit ( $^{\circ}\text{C}$  or  $^{\circ}\text{F}$ ), and the selected code will flash slowly.

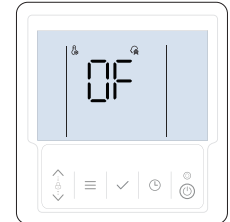
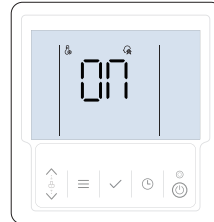

## Tank volume setting

In the installation item selection interface, press  $\wedge$   $\vee$  buttons to select the item code 12.

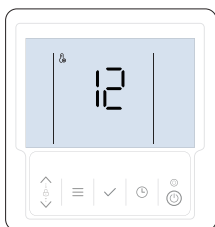

Press  $\checkmark$  button to enter the tank volume setting.

Press  $\checkmark$  button to confirm the tank volume setting and return to the item selection interface.

Press  $\equiv$  button to return to item selection interface and do not change the tank volume.

Press  $\wedge$   $\vee$  buttons to set silence function on (ON) or off (OFF). and the selected code (ON or OFF) will flash slowly.

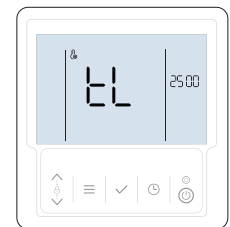
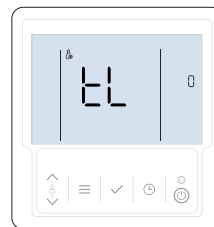

## Manual defrosting setting

In the installation item selection interface, press  $\wedge$   $\vee$  buttons to select the item code 15.

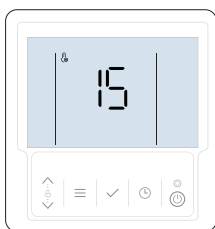

Press  $\checkmark$  button to enter the manual defrosting setting.

Press  $\equiv$  button to return to item selection interface and do not change manual defrosting function status.

Press  $\wedge$   $\vee$  buttons to set disinfection function on (ON) or off (OFF). and the selected code (ON or OFF) will flash slowly.

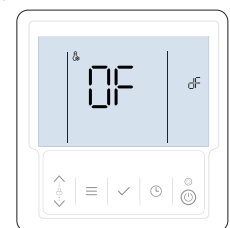
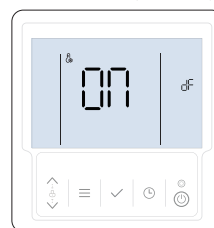

Press  $\checkmark$  button to confirm the manual defrosting setting and return to the main interface.

If on has been selected, code dF will be displayed at the temperature site in the main interface. Then the unit will go to defrost. The code dF will disappear after defrosting is finished or after turning off the unit.

If off has been selected, it will return to the main interface. Then the unit will quit defrosting and restore normal display.

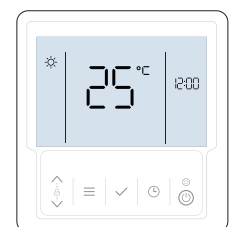
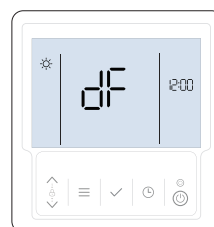

# Operation instructions

## Refrigerant recovery setting

In the installation item selection interface, press  $\wedge$   $\vee$  buttons to select the item code 18.

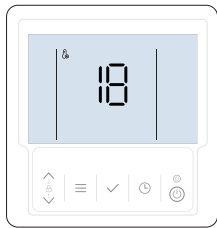

Press  $\checkmark$  button to enter the refrigerant recovery setting.

Press  $\equiv$  button to return to item selection interface and do not change refrigerant recovery function status.

Press  $\wedge$   $\vee$  buttons to set refrigerant recovery function on (0N) or off (0F), and the selected code (0N or 0F) will flash slowly.

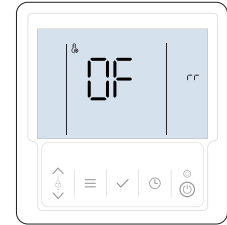
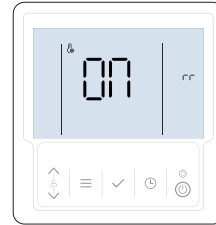

Press  $\checkmark$  button to confirm the refrigerant recovery setting and return to the main interface.

If on has been selected, code rr will be display at the temperature site in the main interface. Then unit will go to defrost. The code rr will disappear after defrosting finished or after turning off the unit.

If off has been selected, it will return to the main interface. Then unit will quit defrosting and restore normal display.

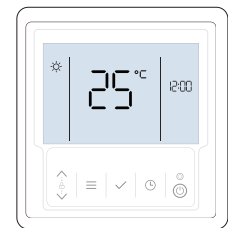
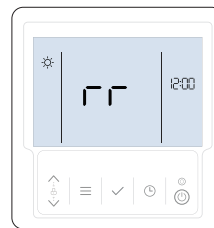

## Power consumption estimation setting

In the installation item selection interface, press  $\wedge$   $\vee$  buttons to select the item code 19.

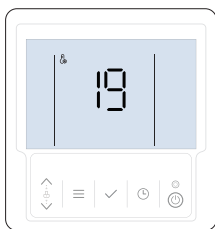

Press  $\checkmark$  button to enter power consumption estimation setting.

Press  $\checkmark$  button to confirm this function and return to the item selection interface.

Press  $\equiv$  button to return to item selection interface and do not change the function status.

Press  $\wedge$   $\vee$  buttons to set power consumption estimation function on (0N) or off (0F), and the selected code (0N or 0F) will flash slowly.

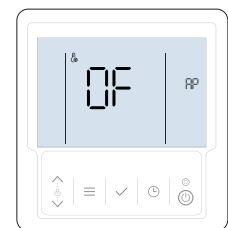
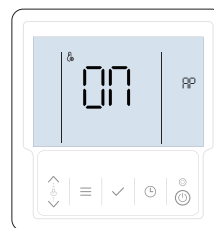

## Operating time statistics setting

In the installation item selection interface, press  $\wedge$   $\vee$  buttons to select the item code 20.

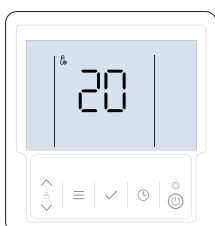

Press  $\checkmark$  button to enter the operating time statistics setting.

Press  $\checkmark$  button to confirm this function and return to the item selection interface.

Press  $\equiv$  button to return to item selection interface and do not change the function status.

Press  $\wedge$   $\vee$  buttons to set operating time statistics function on (0N) or off (0F), and the selected code (0N or 0F) will flash slowly.

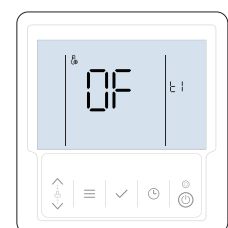
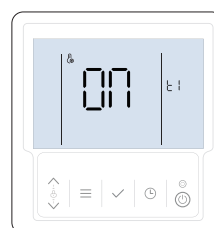

# Operation instructions

## Clock correction setting

In the installation item selection interface, press  $\wedge$ / $\vee$  buttons to select the item code 26 for the correction of Winter and Summer Time.

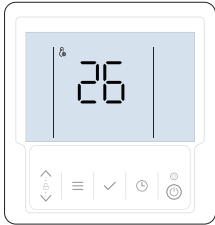

Press  $\checkmark$  button to enter clock correction setting.



Press  $\checkmark$  button to confirm clock correction setting and return to the item selection interface.

Press  $\equiv$  button to return to item selection interface and do not change the clock correction.

Press  $\wedge$ / $\vee$  buttons to set clock correction hours (range -5~5, default 0), and the correction hours will flash slowly.

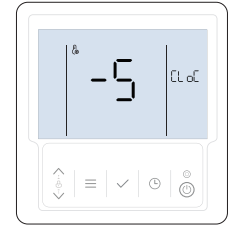
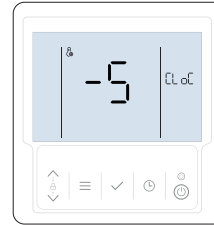

## Validity period setting

In the installation item selection interface, press  $\wedge$ / $\vee$  buttons to select the item code 27.

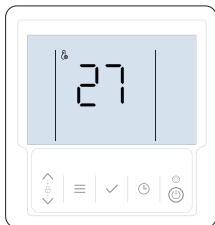

Press  $\checkmark$  button to enter the validity period setting.

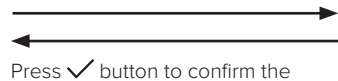

Press  $\checkmark$  button to confirm the validity period setting and return to the item selection interface.

Press  $\equiv$  button to return to item selection interface and do not change the validity period.

Press  $\wedge$ / $\vee$  buttons to set validity period within 24 hours (07) or long term (0F), and the selected code (07 or 0F) will flash slowly.

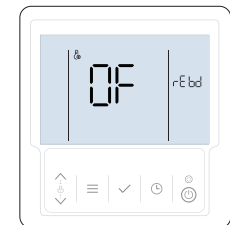
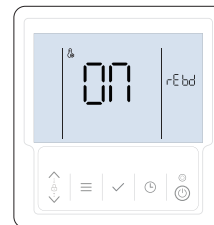

## E-heater reset

In the installation item selection interface, press  $\wedge$ / $\vee$  buttons to select the item code 28 for resetting E-heater as invalid.

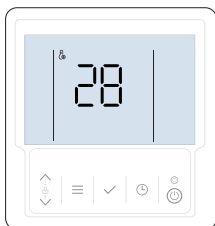

Press  $\checkmark$  button to enter the validity period setting.

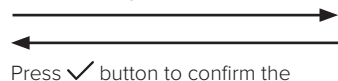

Press  $\checkmark$  button to confirm the validity period setting and return to the item selection interface.

Press  $\equiv$  button to return to item selection interface and do not change the validity period.

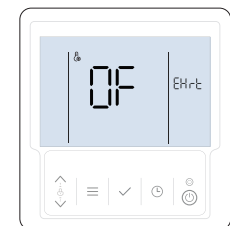
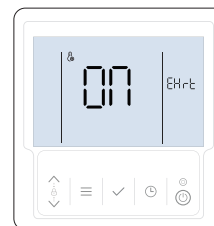

Press  $\wedge$ / $\vee$  buttons to set disinfection function on (07) or off (0F), and the selected code (07 or 0F) will flash slowly.



If selected on, the unit will reset the E-heater settings, then automatically self-check the E-heater after power on.

# Operation instructions

## Unlock/lock keyboard

When controller is locked and the  icon is lightened, any button is invalid at this time. Long press the  +  buttons for 1 sec. to unlock/lock the keyboard. The keyboard will be locked automatically when no button operation for 120 sec.

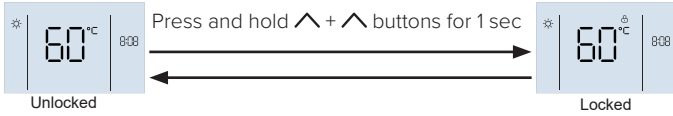

## Turn the unit on/off

Press the  button to turn on or turn off the unit, When the keyboard is unlocked.

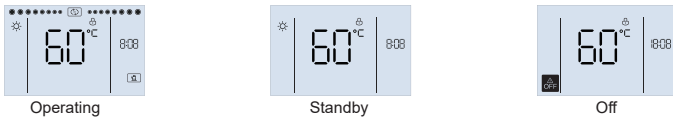

If unit is turned on and not operating, the main interface will display setting mode, current temperature, clock and so on. If unit is turned on and operating, the operating icon will flash. If unit is turned off, the  icon will be lightened and operating icon and mode icon will be distinguished.

Some interface examples of operating, standby and OFF state are as follows:



## Operating mode and parameter setting

### 1. Restart offset temperature setting

The code  displayed at  means Trdh (restart offset temperature for domestic hot water mode), and the value displays at temperature site .

When the temperature of the water tank drops beyond Trdh, the unit will start heating.

The setting method is as follows:

### NOTE

1. If one function of OPT.Backup, timer, solar energy and smart grid has been activated, the actual Trdh is automatically set to no larger than the default value.
2. If no function of OPT.Backup, timer, solar energy and smart grid is activated, the actual Trdh is equal to the set value.

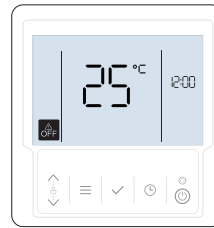

In the main interface, press the  button to enter the operating mode selecting interface, and the selected mode will flash slowly. For this unit, there is only domestic hot water mode to be selected.

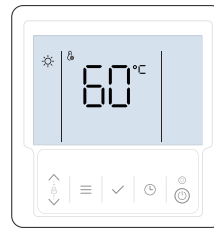

No button operation for 60 sec. to return to main interface (don't change setting mode).

Press  button to confirm the operating mode and return to main interface.

Press  button to go to function activation interface.

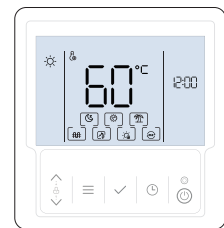

In the operating mode setting interface, long press  button for 3 sec. to enter Trdh value setting, and the setting value will flash slowly.

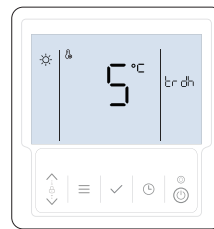

Press  button to confirm the setting Trdh and return to main interface.

Press  button or no button operation for 60 sec to return to main interface (don't change setting mode).

Press   buttons to set the restart offset temperature Trdh (range: 2~40°C, default: 15°C).

# Operation instructions

## 2. Parameters of E-heater setting

If the unit does not equip E-heater, these parameters can not be set. These parameters include Td (the lowest ambient temperature of auto-operating with heat pump and E-heater together, range -15~44°C, default 0°C, code **t d** displays at **00**), TrEH (the restart offset temp. of E-heater, range 1~40°C, default 10°C, code **t r EH** displays at **0000**) and TsEH (the restart offset temperature of E-heater, range 0~39°C, default 0°C, the code **t s EH** displays at **0000**).

Td is a limit value to determine if e-heater and heat pump can operate at the same time or not. If the ambient temperature is higher than or equal to Td, the unit will only start heat pump at first, then start e-heater after heat pump stopped if the water temperature does not reach target temperature (code: T5s) because that heat pump reached its highest water temperature (code: T5stop), or ambient temperature has be over the declared operating range, or some heat pump faults occurred. If the ambient temperature is lower than Td, the unit will only start heat pump at first, then start e-heater if the water temperature is lower than the difference between T5s and TrEH, and the heat pump will operate until water temperature reached T5stop (if T5stop is lower than T5s) or T5s (if T5stop is higher than T5s), and the e-heater will operate until the water temperature reached the difference between T5s and TsEH (if T5stop is higher than the difference between T5s and TsEH) or reached T5s (if T5stop is lower than the difference between T5s and TsEH).

During setting **00:00** displays Td value, and **00** displays code **t d** (Td). The setting method is as follows:

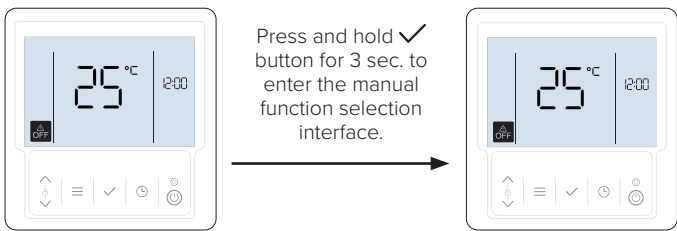

The main interface

In the manual function selection interface, the selected function icon will flash slowly.

Press **✓** buttons to select the E-heater icon **[EH]**.

Press and hold **✓** button for 3 sec. to enter the parameters of E-heater setting interface.



Press **^** **v** buttons to set TsEH.

Press the **✓** button to confirm TsEH then enter TrEH setting interface.

Press **^** **v** buttons to set Td.

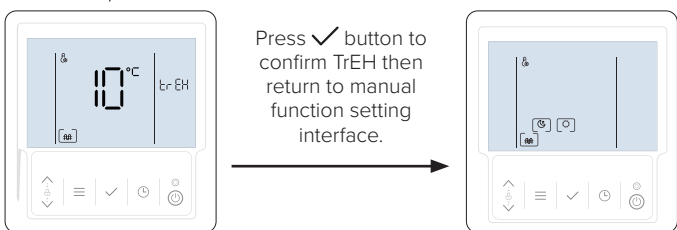

Press **^** **v** buttons to set TrEH.

## Target temperature setting

In the main interface, press **^** **v** buttons to adjust target temperature. During adjusting, press **≡** or **✓** button to confirm settings then return to main interface, or no press any button for 60 sec then confirm settings automatically and return to main interface.

An interface example of setting is as follows:



# Operation instructions

## Clock setting

If the controller is successfully connected to the network, the clock will update automatically. If not, the user can set the clock manually on the controller. Only the clock icon and the current setting parameters will illuminate during clock setting.

If the controller does not receive the correct time from the network after first power-on or following a prolonged power outage, the clock will default to 12:00 and flash slowly, prompting the user to set the correct time. Once the user completes the time setting, or the controller synchronises with the network, the clock will stop flashing and remain on.

The setting method is as follows: (For example: 2024.2.10 12:00)

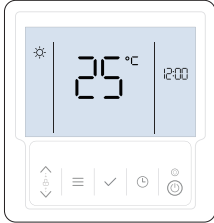

In the main interface, press **⏸** button for 3 sec. to enter clock setting, default enter year setting, and the year code number will flash slowly.

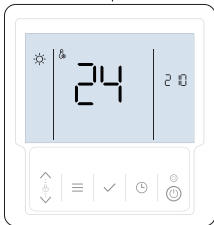

Press **▲▼** buttons to set year at **⓪⓪** (only display tens and single digits, for example, 24 means the year 2024).

Then press **✓** button to confirm year setting, then enter month setting, and the month code number will flash slowly.

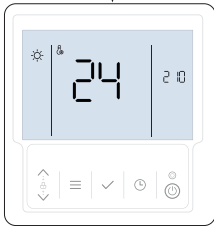

Press **▲▼** buttons to set month at the first two of **⓪⓪⓪⓪**. For example, code 2 means February.

Press **✓** button to confirm month setting, then enter day setting, and the day code number will flash slowly.

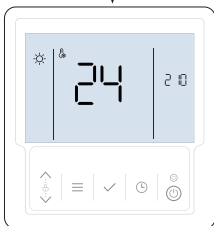

Press **▲▼** buttons to set day at the last two of **⓪⓪⓪⓪**. For example, code 10 means 10th.

Press **✓** button to confirm the date setting, then enter hour setting, and the hour code number will flash slowly.

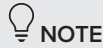

### NOTE

During setting, press button to return to main interface without saving settings, or no button operation for 60 sec then confirm settings automatically and return to main interface.

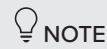

### NOTE

## Timer setting

There are 3 mutually exclusive type to set timer, including point timer, period timer, and appointment timer, which one is available depends on the installation settings. Only the activated timer numbers can be displayed in the main interface. The timer step is 10 min. in all timer type.

If the functions of manual on/off, daily timer and weekly schedule conflict, the priority is as follows: manual on/off > holiday away > weekly schedule > daily timer. In case of conflict between different timer numbers, the later set timer prevails and the previous conflicting setting is automatically set to inactive status.

After the timer settings are completed, the activated timer numbers are displayed at the main interface. When the clock reaches the timer point, according to the switching action at that time point, **🕒** or **🕒** will be lightened respectively and unit will execute the corresponding commands (on/off, target temperature).

1. If user changes the target temperature or manually turns on/off unit when the timer is already in effect, on this day the current timer will be invalidated until the time of next timer then executes the corresponding command according to the timer setting.

For example (point timer), the user sets timer ① (5:00 on, target 55°C), timer ② (12:00 off), timer ③ (14:00 on, target 60°C). If user adjusts the target temperature to 60°C at 7:00, the target temperature will be set to 60°C directly until 12:00 then unit is turned off; if user manually turns off the unit at 7:00, the unit will be turned off immediately until 14:00 when timer ③ is executed.

For example (appointment timer), the user sets timer ① (12:00~14:00, target 50°C) and timer ② (20:00~23:00, target 60°C). If the user has adjusted target temperature at 7:00 (i.e. even if the final temp. is the same as the original target), the timer ① will be invalid on this day, and the unit will keep the current on/off status until 14:00 (the end of timer ①), if needing the unit to operate, please turn it on manually.

2. Under the timer, the **🕒** icon is displayed and the LED light is off when the unit is not turned on, and the run icon is displayed and the LED light is on when the unit is turned on.

3. If the time between timer on and off clocks is too short, it will cause that the unit fail to heat up to the set water temperature, so it is recommended that the total time between timer on and off clocks is longer than 8 hours.

4. The timer, solar energy, smart grid, and OPT.Backup functions are mutually exclusive, and the timer can only be used when these functions are not activated.

An interface example (No.1, No.3 and No.4 have been activated, but No.2 is not activated) is as follows:

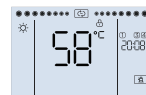

# Operation instructions

## 1. Point timer setting

There are 4 point timers in this type. Every timer includes the point clock, operating mode (including OFF mode), target temperature (except OFF mode). Controller will execute the setting action at the point clock.

It is possible to set the on/off timers in any combination (such as 4 on timers and 0 off timer, 3 on timers and 1 off timer, 2 on timers and 2 off timers, 1 on timer and 1 off timer, 2 on timers and 1 off timer, etc.), and it is recommended that the number of off timers be less than or equal to the number of on timers.

By different combinations of point timers, it is possible to avoid unsuitable operating periods, and to operate during periods with higher ambient temperatures or valley price electricity.

Two examples of point timer settings are as follows:

Example 1:

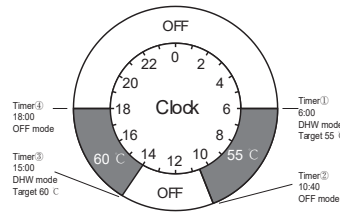

Example 2:

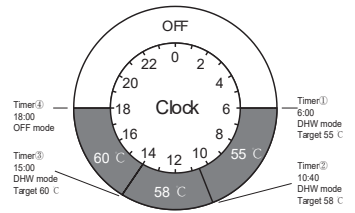

Setting method is as follows:

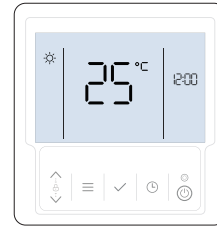

### NOTE

In the timer code selection interface, hold the button for 3 seconds to cancel the selected timer. In the timer code selection interface, press the button or wait 60 seconds to return to the main interface. Unconfirmed timers remain unchanged. In the timer parameter setting interface, press the button or wait 60 seconds to return to the number selection interface. Unconfirmed parameters remain unchanged.

In the main interface, press button to enter timer setting, then display selecting number interface, and the timer code ① (default selected ①) will flash slowly.

If no timer has been set, only the timer code ① will be displayed and flash slowly.

If any timer has been set, the codes of set timers (such as ②④) will be displayed with the default selected ①, and the selected code will flash slowly.

Press buttons to select different timer codes. If the selected (such as ② or ④) timer has been set, the set parameters will be displayed.

For example, timer ② and ④ have been set, and timer ① and ③ have not been set, and timer ② has been selected now, so the code ② and ④ are displayed, and code ② is flash slowly, and the parameters of timer ② are displayed in the current interface.

For example, timer ② and ④ have been set, and timer ① and ③ have not been set, and timer ③ has been selected now, so the code ② and ④ are displayed, and code ③ is flash slowly.

Press button to enter the parameter settings of the selected timer, and default to the hour of the timer clock, and the hour will flash slowly. Then press buttons to adjust hour or minute, press button to switch between hour and minute.

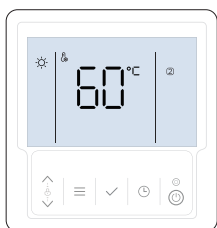

Press buttons to set the target temperature. Then press button to confirm the settings and return to the timer code selecting interface.

Press button to confirm the operating mode. If set the OFF mode then return to the timer code selecting interface, else enter the target temperature setting interface.

Press buttons to select the operating mode between domestic hot water mode and OFF mode.

Press button to confirm the timer clock, then enter the operating mode setting.

# Operation instructions

## 2. Period timer setting

This model includes four period timers. Each timer consists of:

- ON time
- OFF time
- Operating mode
- Target temperature

The controller will carry out the set actions at the programmed times. By combining timers, you can avoid unsuitable operating periods and schedule operation during times of higher ambient temperature or off-peak electricity rates. Setting method is as follows:

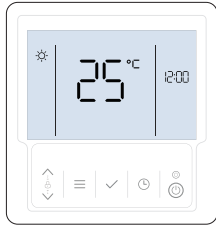
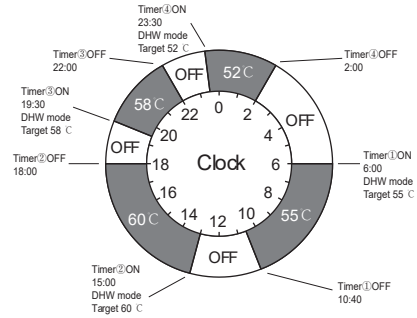

In the main interface, press button to enter timer setting, then display selecting number interface, and the timer code (default selected ) will flash slowly.

If no timer has been set, only the timer code will be displayed and flash slowly.

If any timer has been set, the codes of set timers (such as and ) will be displayed with the default selected , and the selected code will flash slowly.

Press buttons to select different timer codes. If the selected (such as or ) timer has been set, the set parameters will be displayed.

For example, timer and have been set, and timer and have not been set, and timer has been selected now, so the code and are displayed, and code is flash slowly, and the parameters of timer are displayed in the current interface.

For example, timer and have been set, and timer and have not been set, and timer has been selected now, so the code and are displayed, and code is flash slowly.

Press button to enter the on parameter settings of the selected timer, and default to the hour of the timer clock, and the hour will flash slowly, and the icon will be lightened.

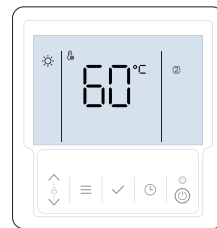
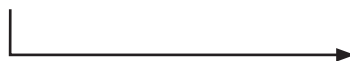

Press buttons to set the target temperature. Then press button to confirm the settings and return to the timer code selecting interface.

Press the button to confirm the mode, then enter target temperature setting.

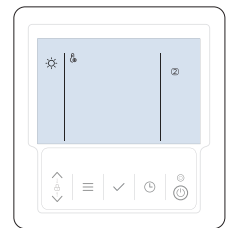

Press the button to confirm the set clock, then enter the mode setting.

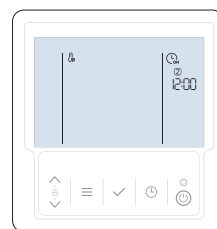

Press buttons to adjust hour or minute, press button to switch between hour and minute.

The default order is hours first and then minutes.

Press the button to confirm the set clock. After pressing the button in minutes, enter the OFF clock setting.

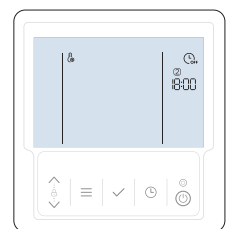

Press buttons to adjust hour or minute, press button to switch between hour and minute.

The default order is hours first and then minutes.

### NOTE

1. During setting, in the timer code selecting interface, when the icon is displayed, long press button for 3 sec. to cancel the selected timer, and the number will be distinguished.
2. During setting, in the timer code selecting interface, press button to return to main interface, or no button operation for 60 sec then return to main interface, and do not change the activation of any unconfirmed point timer.
3. During setting, in the parameters setting interface of timer, press button to return to selecting number interface, or no button operation for 60 sec then return to selecting number interface, and do not change any unconfirmed parameters.

# Operation instructions

## 3. Appointment timer setting

There are 4 period timers in this type. Every timer includes the start and end clocks of water usage, operating mode and target temperature. Controller will send the setting parameters to unit, then unit will automatically calculate the heat up time according to these appointment parameters, ambient temperature and current water temperature, then automatically operate at a suitable time to heat the water up to target temperature before the start clock of water usage of the set timer.

By appointment timers, users do not need to worry about when to turn on or how long to ensure sufficient hot water usage. Users only need to tell the unit when to use water and how much water temperature, and the unit can intelligently determine the timing of turning on.

An example of period timer settings is as follows:

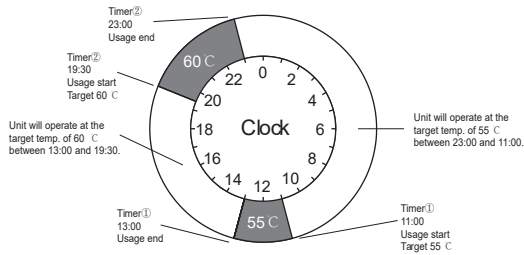

The setting method is as follows:

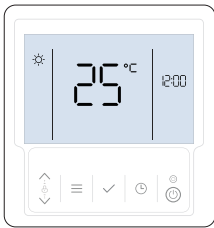

In the main interface, press button to enter timer setting, then display selecting number interface, and the timer code (default selected ) will flash slowly.

If no timer has been set, only the timer code will be displayed and flash slowly.

If any timer has been set, the codes of set timers (such as ②) will be displayed with the default selected , and the selected code will flash slowly.

Press buttons to select different timer codes. If the selected (such as ② or ④) timer has been set, the set parameters will be displayed.

For example, timer ② and ④ have been set, and timer ① and ③ have not been set, and timer ② has been selected now, so the code ② and ④ are displayed, and code ② is flash slowly, and the parameters of timer ② are displayed in the current interface.

For example, timer ② and ④ have been set, and timer ① and ③ have not been set, and timer ③ has been selected now, so the code ② and ④ are displayed, and code ③ is flash slowly.

Press button to enter the on parameter settings of the selected timer, and default to the hour of the timer clock, and the hour will flash slowly, and the icon will be lightened.

### NOTE

1. The appointment is set for water usage time, not the on/off time of the unit.
2. After completing the appointment timer setting, it is necessary to ensure that the controller is turned on (The LED above the ON/OFF button is lightened and the icon is extinguished) for the timers to work. If the controller is in off state, please press the ON/OFF button to turn it on.
3. The appointment function will be affected by water consumption, weather changes, using habits and other factors and may not fully achieve the desired results (including water temperature and power consumption), so please use with caution. It is recommended that setting no more than 2 appointments per day, with an interval of no less than 8 hours between appointments and no more than 4 hours per appointment to allow sufficient time for the unit to heat up.

### NOTE

1. In the timer code selection interface, hold the button for 3 seconds to cancel the selected timer. The number will then clear.
2. In the timer code selection interface, press the button or wait 60 seconds to return to the main interface. Unconfirmed timers remain unchanged.
3. In the timer parameter setting interface, press the button or wait 60 seconds to return to the number selection interface. Unconfirmed parameters remain unchanged.

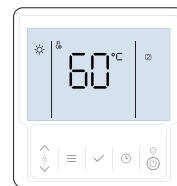

Press buttons to set the target temperature. Then press button to confirm the settings and return to the timer code selecting interface.

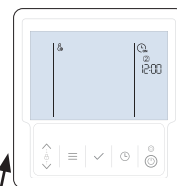

Press buttons to adjust hour or minute, press button to switch between hour and minute.

The default order is hours first and then minutes.

Press the button to confirm the mode, then enter target temperature setting.

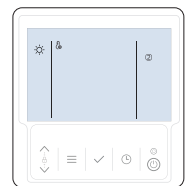

Press the button to confirm the set clock, then enter the mode setting.

Press the button to confirm the set clock. After pressing the button in minutes, enter the OFF clock setting.

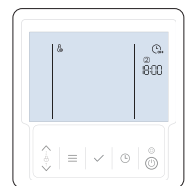

Press buttons to adjust hour or minute, press button to switch between hour and minute.

The default order is hours first and then minutes.

# Operation instructions

## Function activation and parameters setting

In the main interface press and hold button for 3 sec. or press button twice to enter the function selection and activation interface. The available functions depend on the unit, including disinfection, holiday away, OPT.Backup, solar energy, silence, boost and hybrid. During setting, the selected function icon will slowly flash. For example, if disinfection function is not activated the icon will be lightened, and if it is activated the icon will be lightened, and if it is selected but not activated then the icon will slowly flash, and if it is selected and activated then the icon will slowly flash. Press button to activate or deactivate the selected function.

The setting method is as follows:

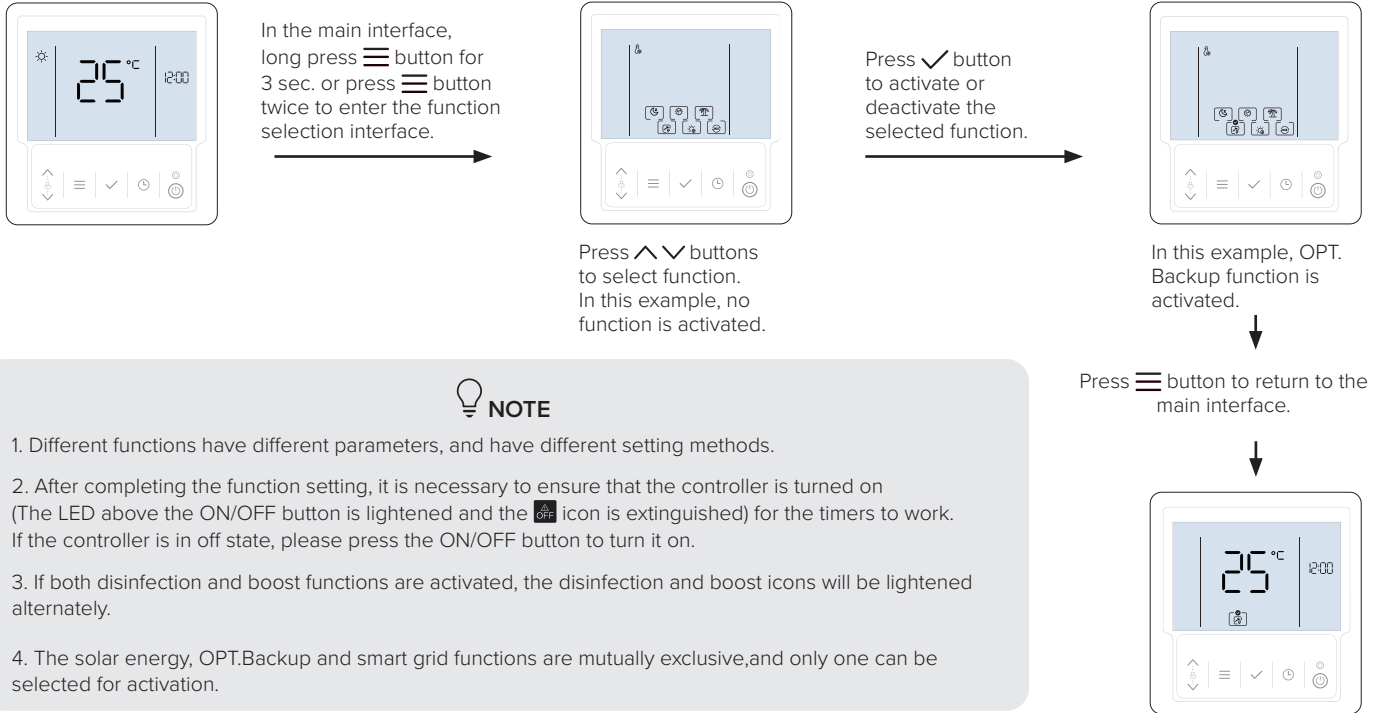

## 1. Holiday away activation/deactivation

Holiday away function allows user to set a holiday schedule (days of holiday away). During the holiday away period, the unit will be OFF or ON (the setting target temperature will be set to 25°C automatically,) which depends on the detail parameter settings of holiday away. At the last day of holiday, the unit will do disinfection once and recover the settings before holiday away.

The setting method is as follows:

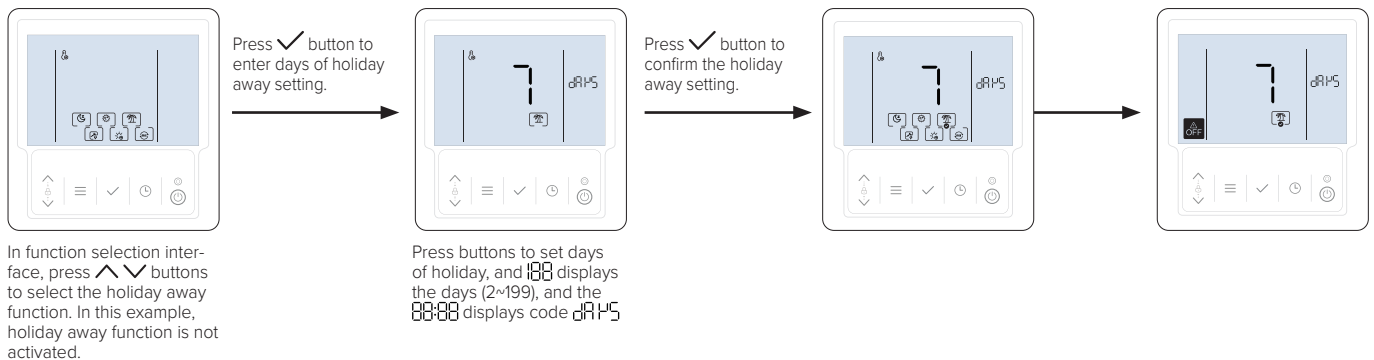

Method for manually cancelling vacation function settings is as follows:

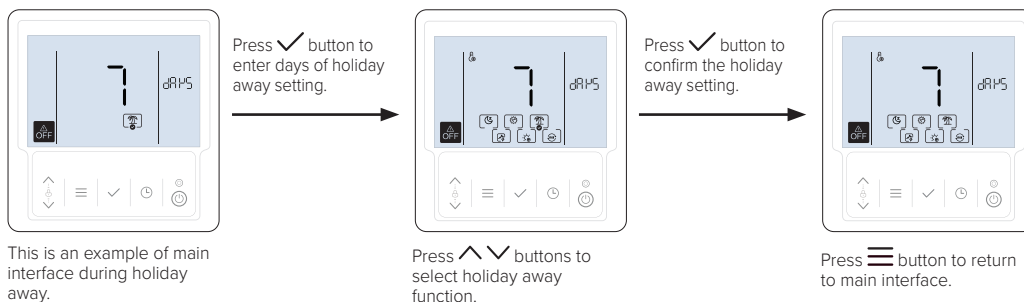

# Operation instructions

## 2. Disinfection parameters setting

Disinfection parameters setting includes disinfection clock, temperature and cycle time. During setting, 88:88 displays disinfection clock (step 10 min.) 88 displays disinfection temperature (55~70°C, default 60°C) and cycle days (2~30 days, default 7 days). After disinfection function being activated, unit will do disinfection (heat up the water to the set disinfection temperature) at the set clock every set cycle days.

The setting method is as follows:

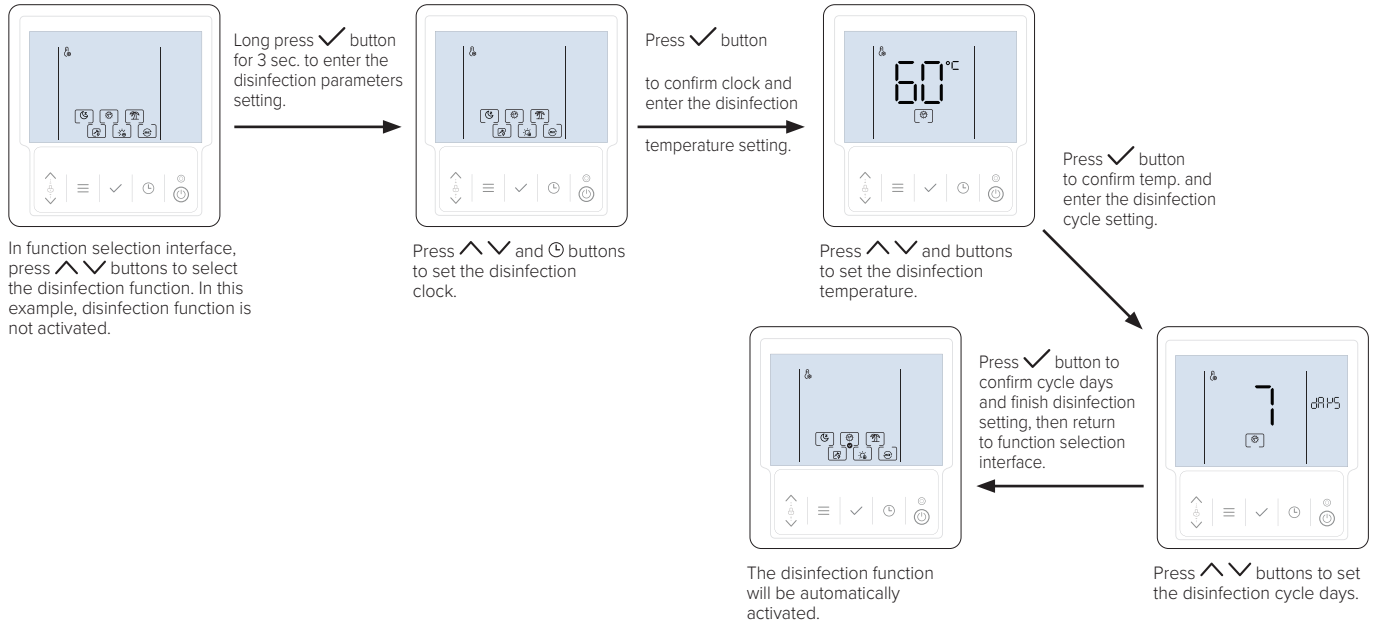

## 3. Holiday away parameter setting

Holiday away parameter is the operating mode (include OFF (OFF, default) and Auto (auto) mode, displayed at 88:88) during holiday. If the set mode is OFF, then the unit will be turned off during holiday. If the set mode is Auto, then the unit will be turned off or heat the water up to 25°C by the controller self-judgment for anti-freezing.

The setting method is as follows:

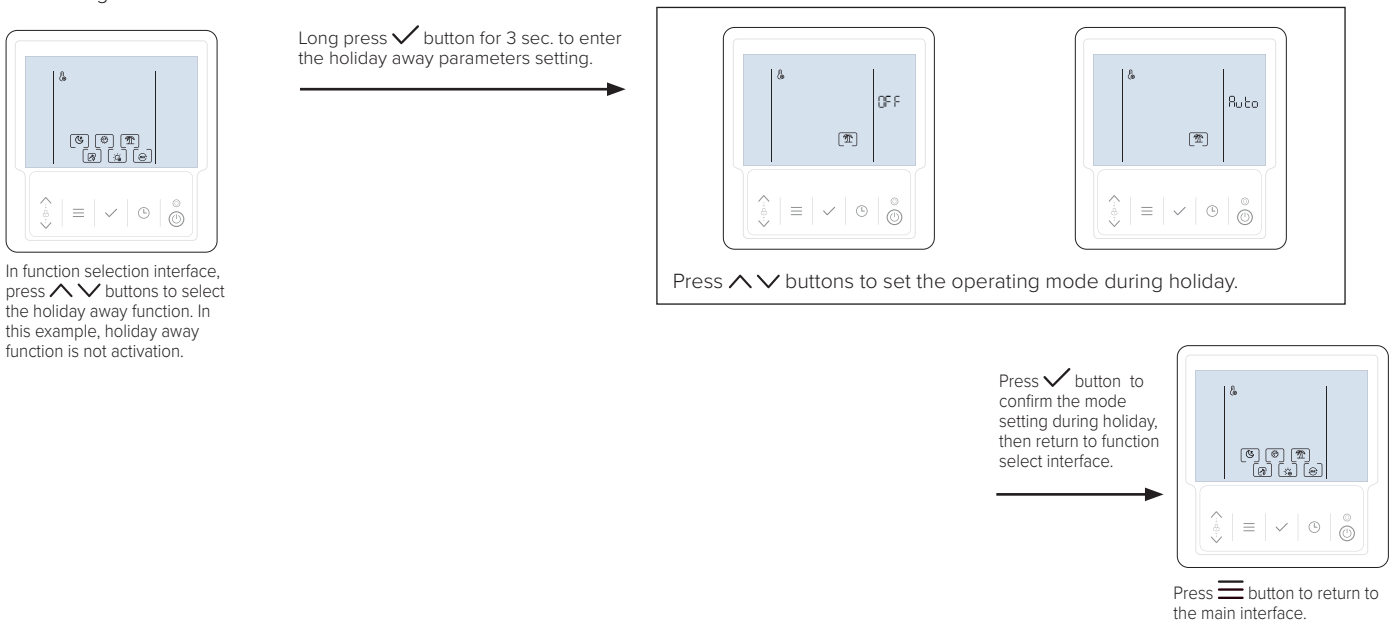

# Operation instructions

## 4. Solar energy parameter setting

Solar energy parameter is the operating mode (include PLUS (PLUS, default) and ONLY (ONLY) mode, displayed at 88:88) when the function is valid. If the set mode is PLUS, then the controller will increase the target temperature by 10°C automatically when the solar energy signal on. If the set mode is ONLY, then the controller will turn on the unit only when the solar energy signal on.

The setting method is as follows:

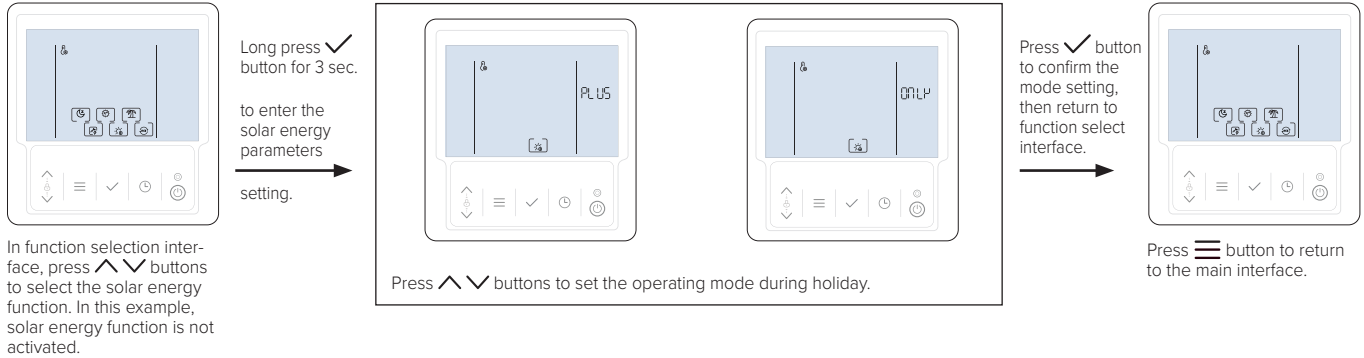

## 5. Hybrid parameter setting

Hybrid parameter is an ambient temperature (code: T4ming) of heat pump operating limit. During setting, the 88:88 will display the ambient temperature (-14~20°C, default 5), and the 88 will display code E4. If the ambient temperature is lower than T4ming, the heat pump will stop operating, and need to operate boiler to continue heating water.

The setting method is as follows:

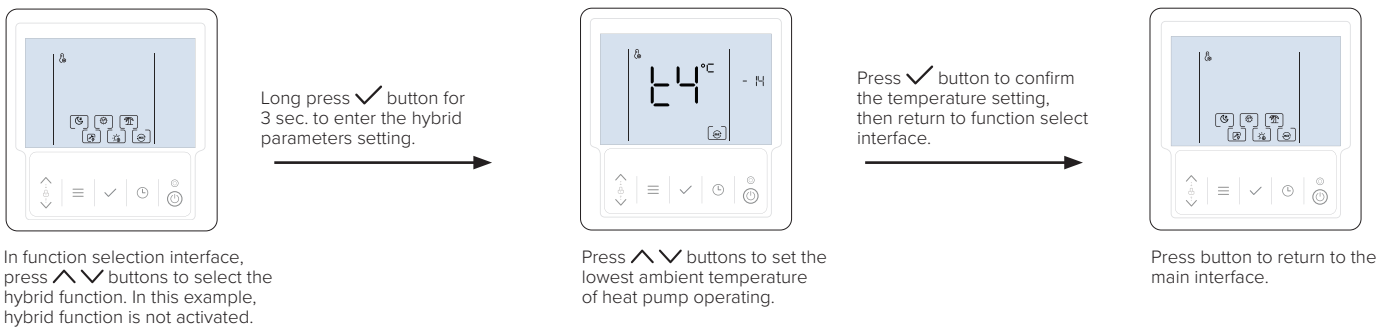

## 6. Silence activation/deactivation

Silence function allows user to set two silence timers. During silence timer, the unit will reduce the operating speeds of compressor and fan motor (depending on silence class) to reduce the operating sound.

The setting method is as follows:

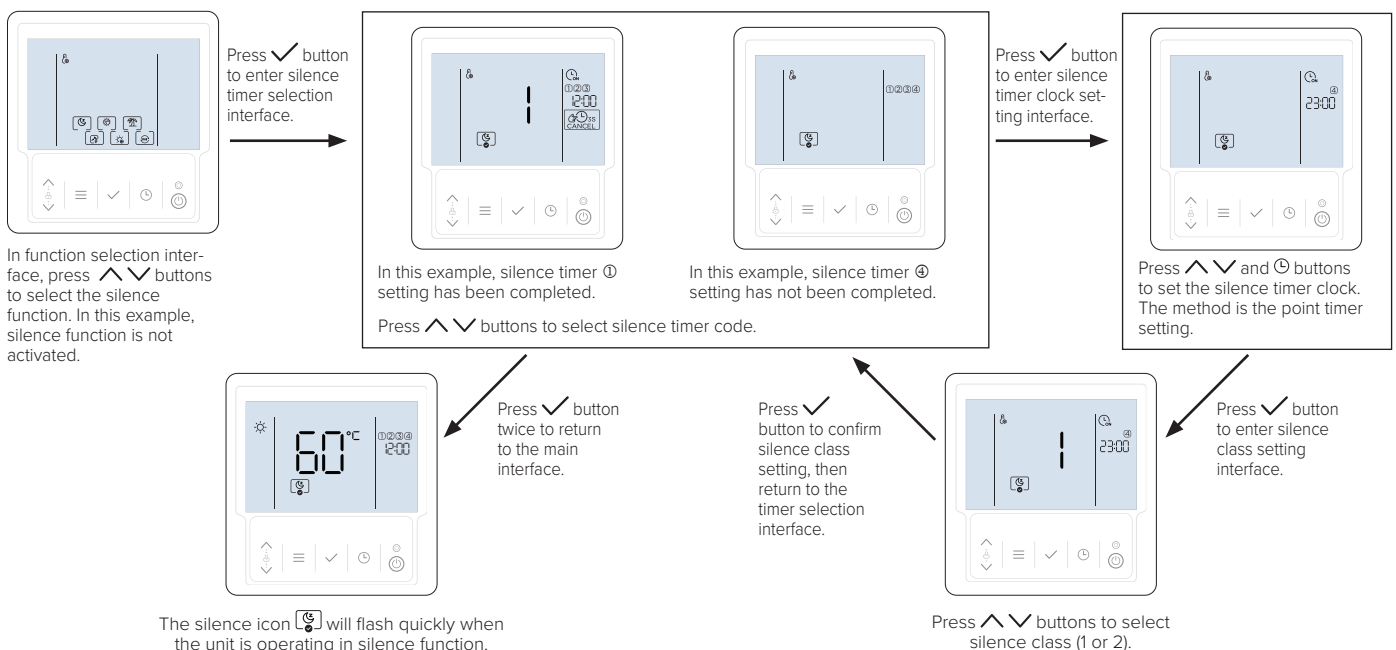

# Operation instructions

## 7. Boost activation/deactivation

Boost function allows user to set two boost timers. During boost timer, the unit will increase the operating speeds of compressor and fan motor to increase the unit capacity. If silence timer meets boost timer, the silence timer is prior.

The setting method is as follows:

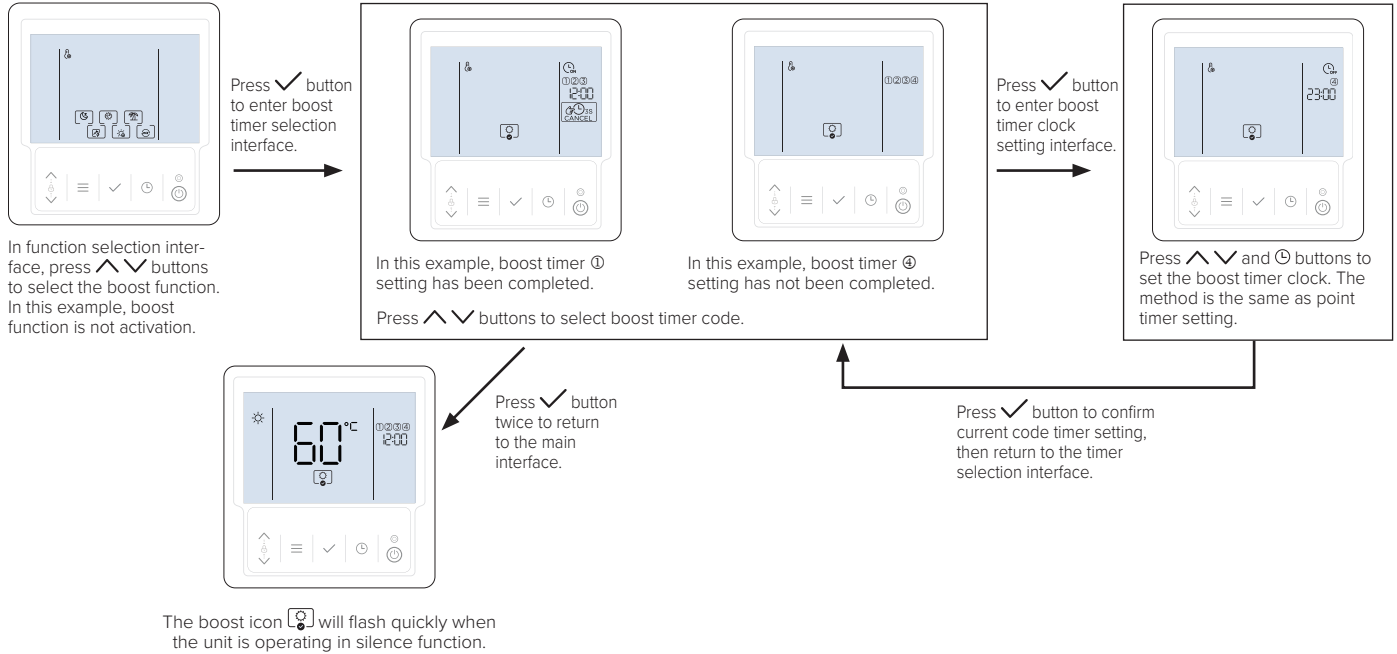

## Manual function

In main interface, long press ✓ button for 3 sec. to enter manual function selection interface, setting icon and manual function icons (such as e-heating , disinfection , silence , boost , depend on the installation settings) will be lightened, then press ^/v buttons to select function. If the function is selected, the function icon will slowly flash. Press ✓ button to activate or deactivate the selected manual function. If the function is activated, the function icon (such as disinfection ) and the icon will be lightened together (such as ). In manual silence function, the silence class is fixed to class 1.

The setting method is as follows (such as manual e-heating):

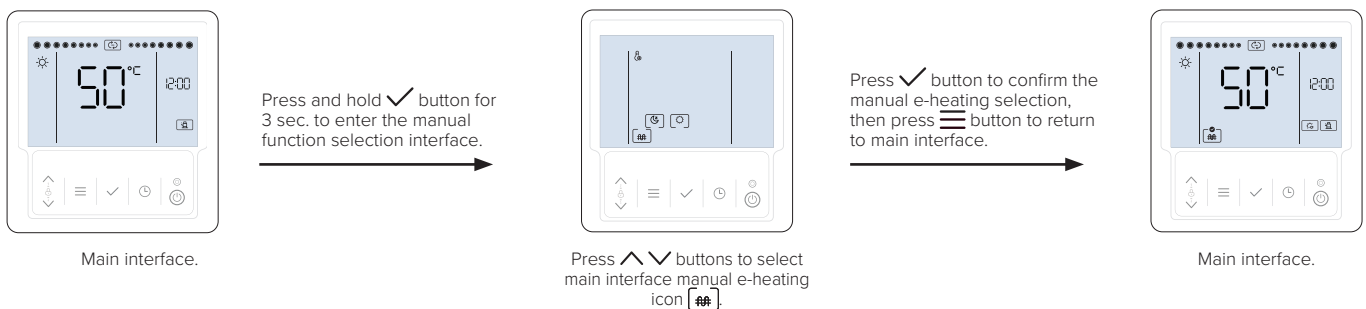

The activated manual function will slowly flash in main interface.

After the manual e-heating function is activated, if the e-heater is off, the manual e-heating function will automatically be deactivated.

After the manual disinfection function is activated, if the water temperature reach the target disinfection temperature, the manual disinfection function will automatically be deactivated.

After the manual boost function is activated, when the compressor of unit stop, then the manual boost function will automatically be deactivated.

# Operation instructions

## Query

Press  $\wedge + \text{Q}$  buttons for 1 sec. to query unit operating parameter. During querying, press  $\wedge \vee$  buttons to switch different parameters. The  $\text{Q}$  icon will be lightened during querying. If some parameters are invalid for some unit, the parameter will be displayed as "--" or "----".

Query explanation:

DISPLAYED AT 88:88	EXPLANATION	DISPLAYED AT 188
Fan speed value (rpm)	Fan speed	FR (FA)
Pulse value	Pulse value of EXV1	E1 (E1)
Compressor speed (Hz)	Compressor speed	Fr (Fr)
Current value (A)	Unit current	Co (Co)
Current value (A)	E-heater current	CE (CE)
Power value (W)	Power input	PA (PA)
Voltage value (V)	AC voltage supply	uo (uo)
Voltage value (V)	DC bus voltage	dC (dC)
Temperature value (°C)	Discharge temp. of compressor (Tp)	tP (Tp)
Temperature value (°C)	Suction temp. of compressor (Th)	tH (Th)
Temperature value (°C)	Heat exchanger temp. of outdoor unit (T3)	t3 (T3)
Temperature value (°C)	Ambient temp. of outdoor unit (T4)	t4 (T4)
Temperature value (°C)	Upper temp. of water tank (T5U)	t5 (T5U)
Temperature value (°C)	Lower temp. of water tank (T5L)	t5 (T5L)
Temperature value (°C)	Ambient temp. limit of E-heater (Td)	tD (Td)
(Trdh)	Restart offset temp. of unit(Trdh)	Temp. value (°C)
(SGSL)	Smart grid class	Class value (0 means no signal)
Power value in kWh, don't display ":"	Cumulative estimated power consumption	AP (AP)
Power value in kWh. The top two display integer, and the last two display decimal, and ":" means the decimal point.	Estimated power consumption of E-heater in 24 hours	EP (EP)
Power value in kWh. The top two display integer, and the last two display decimal, and ":" means the decimal point.	Estimated power consumption of heat pump in 24 hours	HP (HP)
Integer time value in hours, don't display ":"	Cumulative operating time of unit	t1 (t1)
Integer time value in hours, don't display ":"	Cumulative operating time of compressor	t2 (t2)
Integer time value in hours, don't display ":"	Cumulative operating time of E-heater	t3 (t3)
(EF)	Clock chip state	Display code "EF" if chip error, else display "--".
(Er1)	Historical fault code	Fault code
(Er2)	Historical fault code	Fault code
(Er3)	Historical fault code	Fault code
(Ctrl)	Software version of controller	Version number
(ODU)	Software version of outdoor unit	Version number
Address (range 1~63)	Unit address	Ad (Ad)

Some interface examples are as follows:

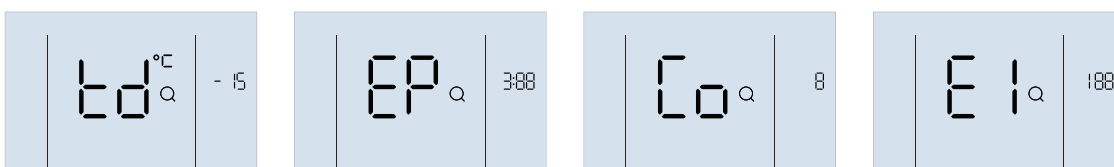

# General introduction

## Outdoor unit

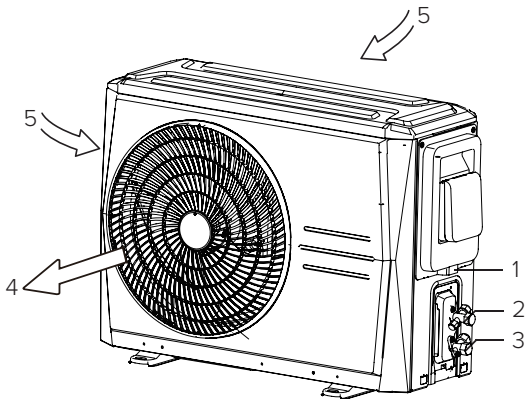

No.	Description
1	Power cord enter
2	Refrigerant gas valve
3	Refrigerant liquid valve
4	Air outlet
5	Air inlet

## Water tank

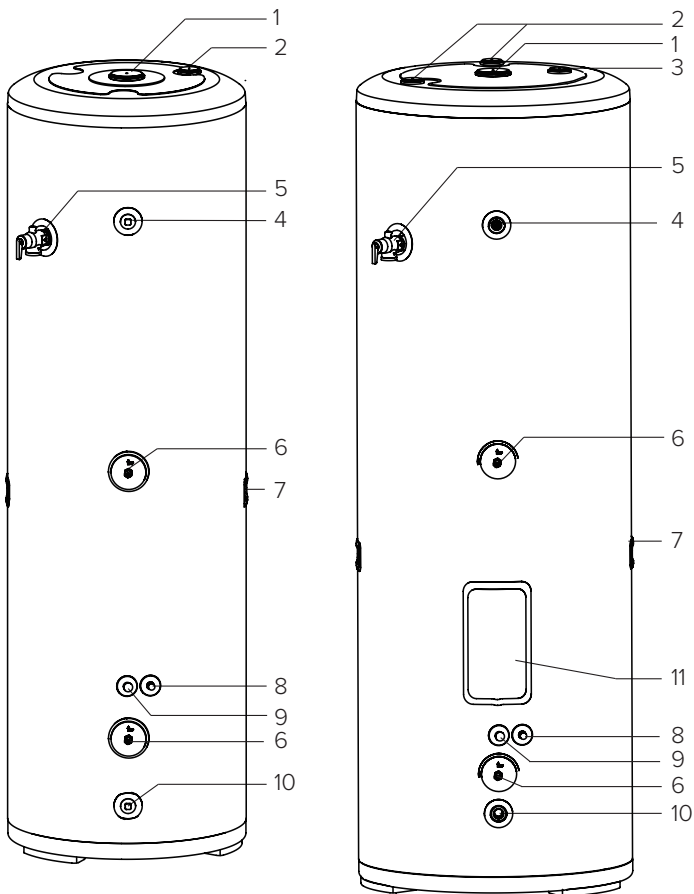

200 L Without Aux.\*

300 L With Aux.\*

\* Electric auxiliary heater is shortened to Aux.

No.	Description
1	Magnesium rod insertion port
2	Foam filling port
3	Reserved port
4	Water outlet
5	Pressure temperature relief valve
6	Water tank temperature sensor
7	Handle
8	Refrigerant gas pipe
9	Refrigerant liquid pipe
10	Water inlet / Drain outlet
11	Electric auxiliary heater

# General introduction

## Specifications

### Specifications

Model number		HPR200	HPR200E	HPR300	HPR300E	
General	Ambient temperature	°C -15~46				
	Leaving water temperature	°C 52~60°C (default 60°C)		52~60°C (default 60°C)		
	Heating	Capacity <sup>1</sup>	W 2800			
		Maximum power input	W 1150			
	Hot water yield	m <sup>3</sup> /h 0.0602				
	Refrigerant piping	Liquid side	mm/inch φ6.35 / φ1/4'			
		Gas side	mm/inch φ9.52 / φ3/8'			
		Max. height difference	m 10			
		Max. refrigerant pipe length	m 20			
	Design pressure	MPa 3.3				
Outdoor Unit	Outdoor unit power supply	V/N/Hz 220-240/1/50				
	Max. current	A 5.2	14.3	5.2	14.3	
	Compressor Type	Type DC inverter rotary				
	Fan	Type	Type DC inverter			
	Air side heat exchanger	Type Hydraulic aluminum fin + Inner grooved copper tube				
	Throttle	Type Electric expansion valve				
	Outdoor sound pressure level	dB(A) 54				
	Dimension	Unit dimension (L*W*H)	mm 804*327*555			
		Packing dimension (L*W*H)	mm 845*390*630			
		Net weight	kg 27			
Refrigerant	Type	R290				
	Charged volume	g 470				
Water Tank	Tank volume	L 200	300			
	Electric heater	Capacity	kW -	2.1	-	2.1
		Power supply	V/N/Hz 220-240V/1/50			
	Dimension	Unit dimension (Ø*H)	mm 505*505*1665		580*580*1735	
		Packing dimension (W*D*H)	mm 1775*635*590		1835*690*670	
		Net weight	kg 74	76	100	102

1. Ambient temperature 19/15°C(DB/WB), Initial water temp. 9°C, Terminative water temp. 60°C.
2. Ambient temperature 19/15°C(DB/WB), Initial water temp. 15°C, Terminative water temp. 55°C.

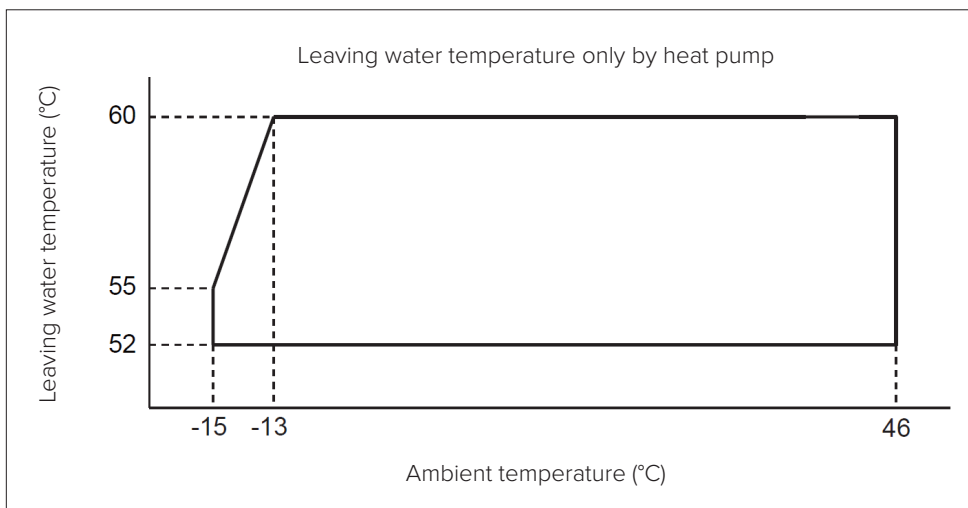

# General introduction

## Specifications (commercial)

### Specifications

			HPR200-1	HPR200E-1	HPR300-1	HPR300E-1	
General	Model number		HPR200-1	HPR200E-1	HPR300-1	HPR300E-1	
	Ambient temperature		°C	-15~46			
	Leaving water temperature		°C	52~70°C (default 60°C)		52~70°C (default 60°C)	
	Heating	Capacity <sup>1</sup>	W	2800			
		Maximum power input	W	1150			
	Hot water yield		m <sup>3</sup> /h	0.0602			
	Refrigerant piping	Liquid side	mm/inch	φ6.35 / φ1/4'			
		Gas side	mm/inch	φ9.52 / φ3/8'			
		Max. height difference	m	10			
		Max. refrigerant pipe length	m	20			
Design pressure		MPa	3.3				
Outdoor Unit	Outdoor unit power supply		V/N/Hz	220-240/1/50			
	Max. current		A	5.2	14.3	5.2	14.3
	Compressor Type		Type	DC inverter rotary			
	Fan	Type	Type	DC inverter			
	Air side heat exchanger		Type	Hydraulic aluminum fin + Inner grooved copper tube			
	Throttle		Type	Electric expansion valve			
	Outdoor sound pressure level		dB(A)	54			
	Dimension	Unit dimension (L*W*H)	mm	804*327*555			
		Packing dimension (L*W*H)	mm	845*390*630			
		Net weight	kg	27			
Refrigerant	Type		R290				
	Charged volume	g	470				
Water Tank	Tank volume		L	200		300	
	Electric heater	Capacity	kW	-	2.1	-	2.1
		Power supply	V/N/Hz	220-240V/1/50			
	Dimension	Unit dimension (Ø*H)	mm	505*505*1665		580*580*1735	
		Packing dimension (W*D*H)	mm	1775*635*590		1835*690*670	
		Net weight	kg	74	76	100	102

1. Ambient temperature 19/15°C(DB/WB), Initial water temp. 9°C, Terminative water temp. 60°C.





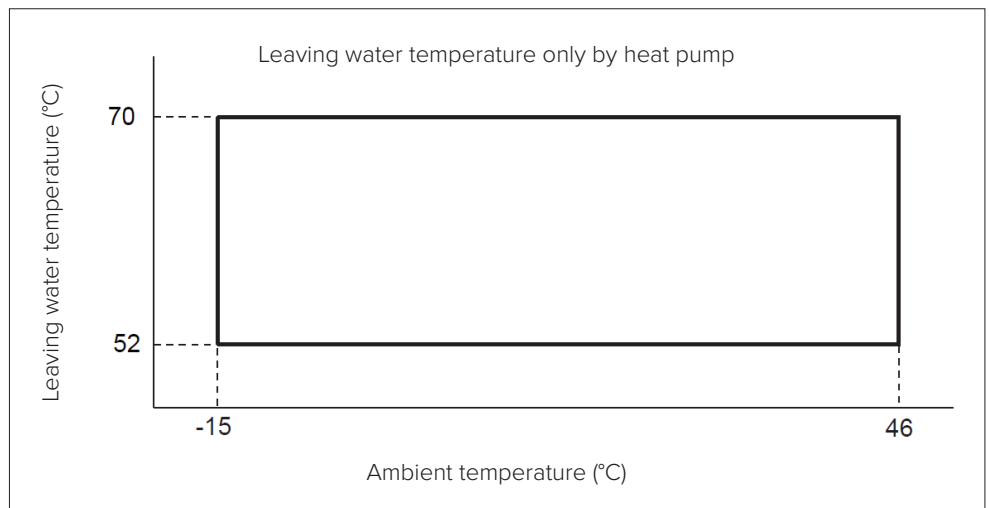



2. Ambient temperature 19/15°C(DB/WB), Initial water temp. 15°C, Terminative water temp. 55°C.

Ambient temperature	Leaving water temperature
-15~46°C	52-70°C



# Before installation

## Accessories

Accessory name		Qty	Image	Purpose
Outdoor unit	Installation manual	1		Outdoor unit and water tank instruction
	Safety manual	1		Safety instructions
	Drain pipe joint	1		For condensate water draining
	Water drainage pipe	1	—	Condensate water drainage of unit bottom plate
	Seal ring	1		Seal between water drainage connection and external machine
	Polypropylene strap	1	—	Wrap the refrigerant tube between outdoor unit and water tank
Water tank	Water tank fixing strip	1		Fixed water tank
	Connector	2		Connect water tank and safe care
	Seal ring	2		Prevent rust between water tank and joint
	Swift connection	1		Refrigerant connection pipe (2m)
	PTR valve	1		Pressure relief

## Space

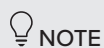

NOTE

During installing, it is necessary to reserve enough installation space and maintenance space according to the following figures.

Do not install the outdoor unit and tank in a enclosed space.

### Outdoor unit installation and maintenance space (unit: mm)

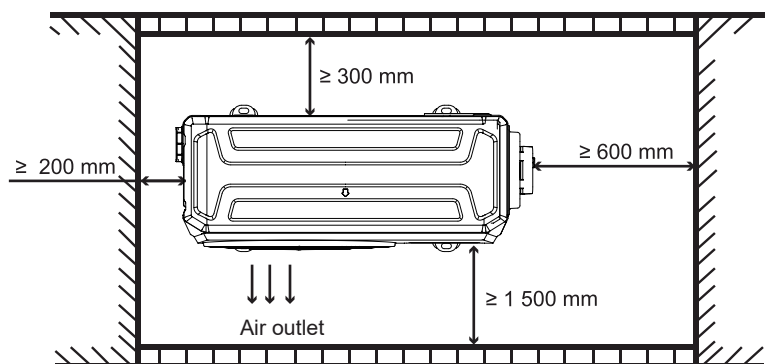
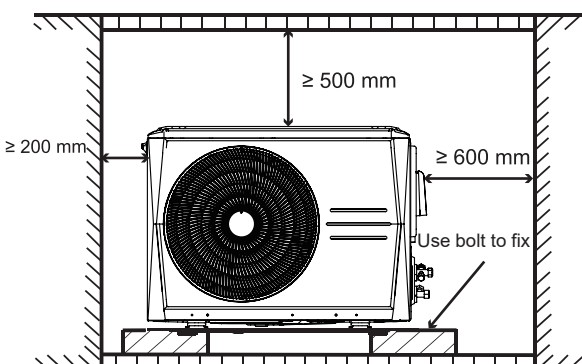

## Before installation

### Water tank installation and maintenance space (unit: mm)

#### NOTE

- If installed fully outdoors, a rain shelter is strongly recommended.
- Outdoor installation: keep at least 200mm clearance from fences.
- Indoor installation: keep at least 600mm clearance from walls.
- Tanks with an electric auxiliary heater: allow at least 1000mm from the wall for maintenance access.

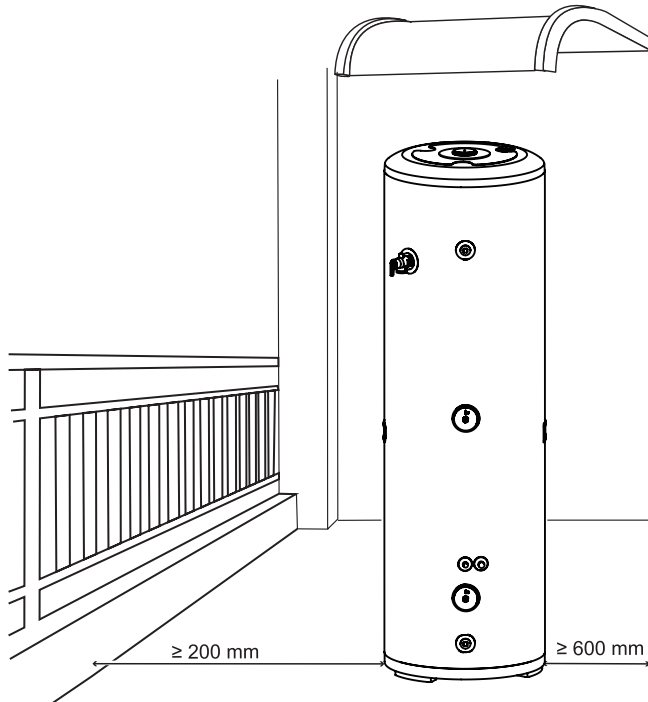

\*Electric auxiliary heater is shortened to Aux.

Without Aux.

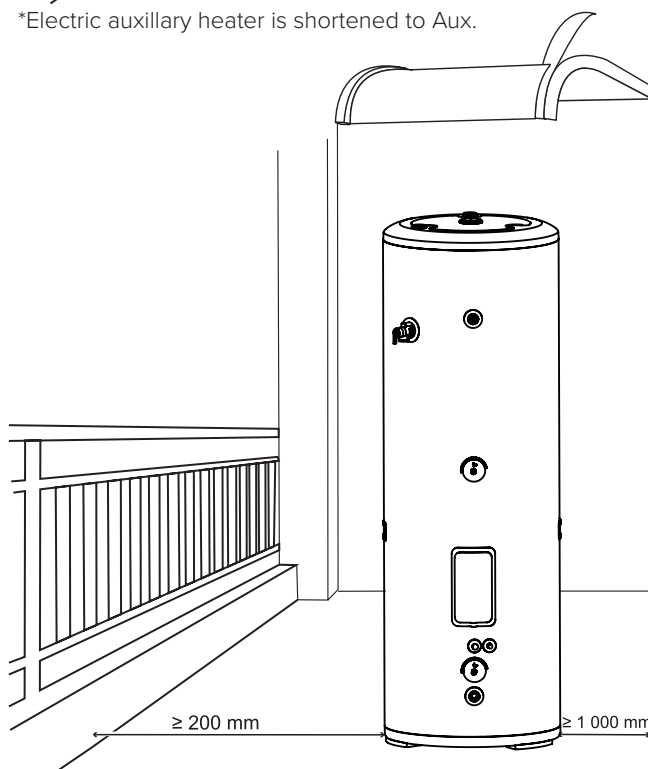
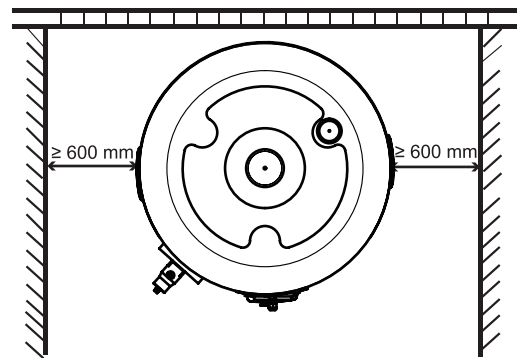

\*Electric auxiliary heater is shortened to Aux.

Without Aux.

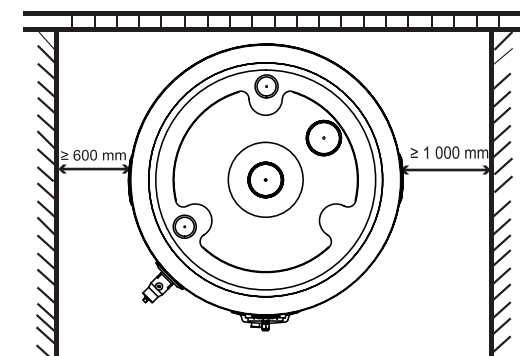

The auxiliary heater is a replaceable component. Ensure sufficient space is provided for maintenance.

# Installation

## NOTE

- Only a dealer or qualified specialist should move, repair, or maintain the unit.
- Install in a location free from direct sunlight or heat sources. If unavoidable, fit a cover to protect the unit.
- The ceiling must be level and strong enough to support the indoor unit's weight.
- Install the unit securely to prevent noise or vibration.
- Remove nearby obstacles; restricted airflow may reduce performance.
- Position the unit as close as possible to the water tank, provided installation requirements are met.
- In coastal or windy locations, install the unit against a wall or fit a baffle to prevent strong winds from blowing back into the unit.
- If installed in a basement, indoors, or confined space, ensure adequate air intake and exhaust. Circulation airflow must be at least 1250 m<sup>3</sup>/h.

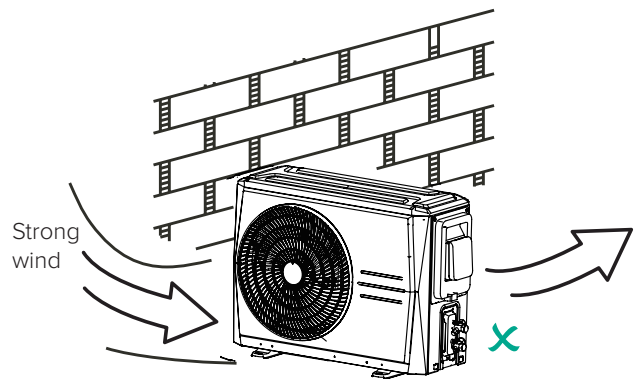
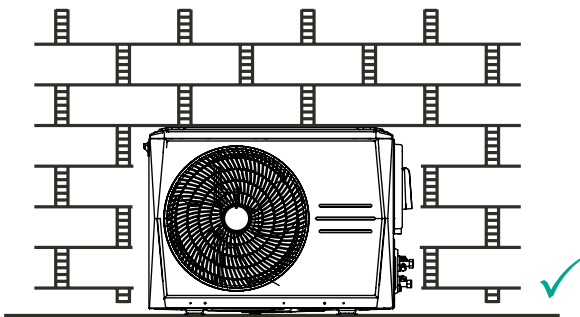

## Dimension and mounting

### Outdoor unit

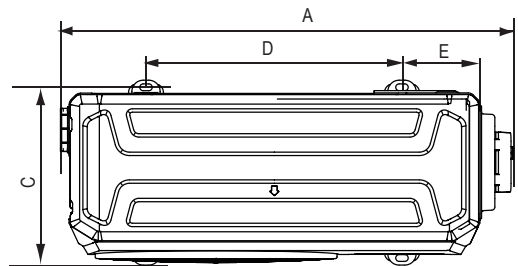
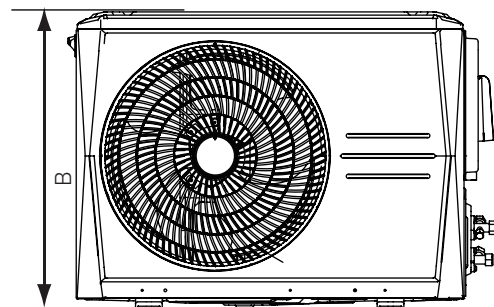

Secure the four bases of the outdoor unit to a flat surface using bolts.

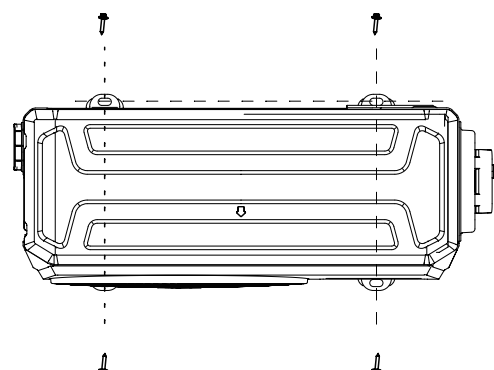

Dimension and mounting dimension				
A	B	C	D	E
804	555	302	452	137

# Installation

## Water tank

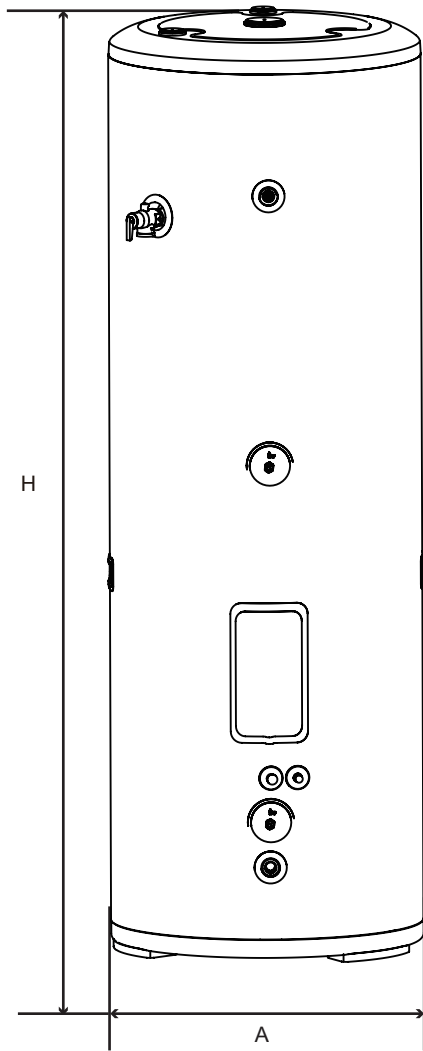

Dimension and mounting dimension				
A	B	C	D	E
804	555	302	452	137

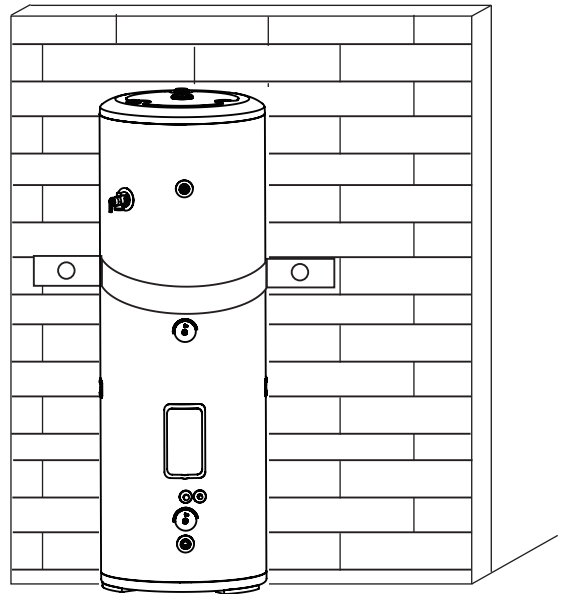

Secure the four bases of the outdoor unit to a flat surface using bolts.

## Drain hole position

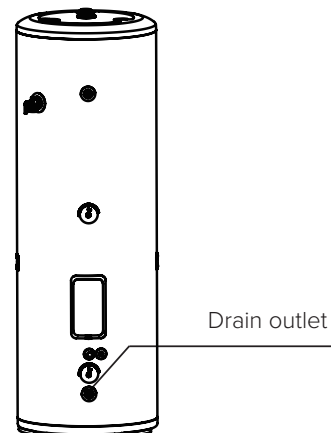
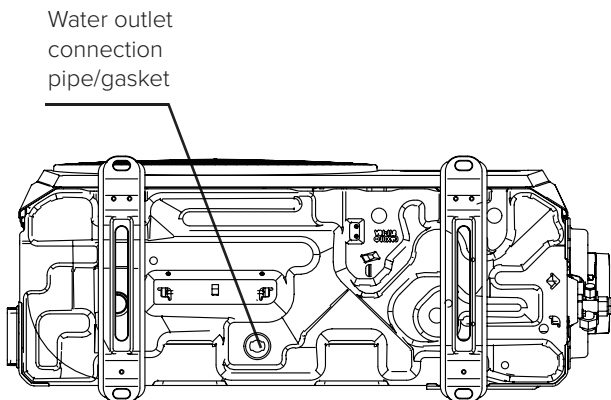

Use an Allen wrench to open the drain valve and release the water. Draining is complete when no more water flows out.

# Installation

## Pipe connection

### Unit connection sketch

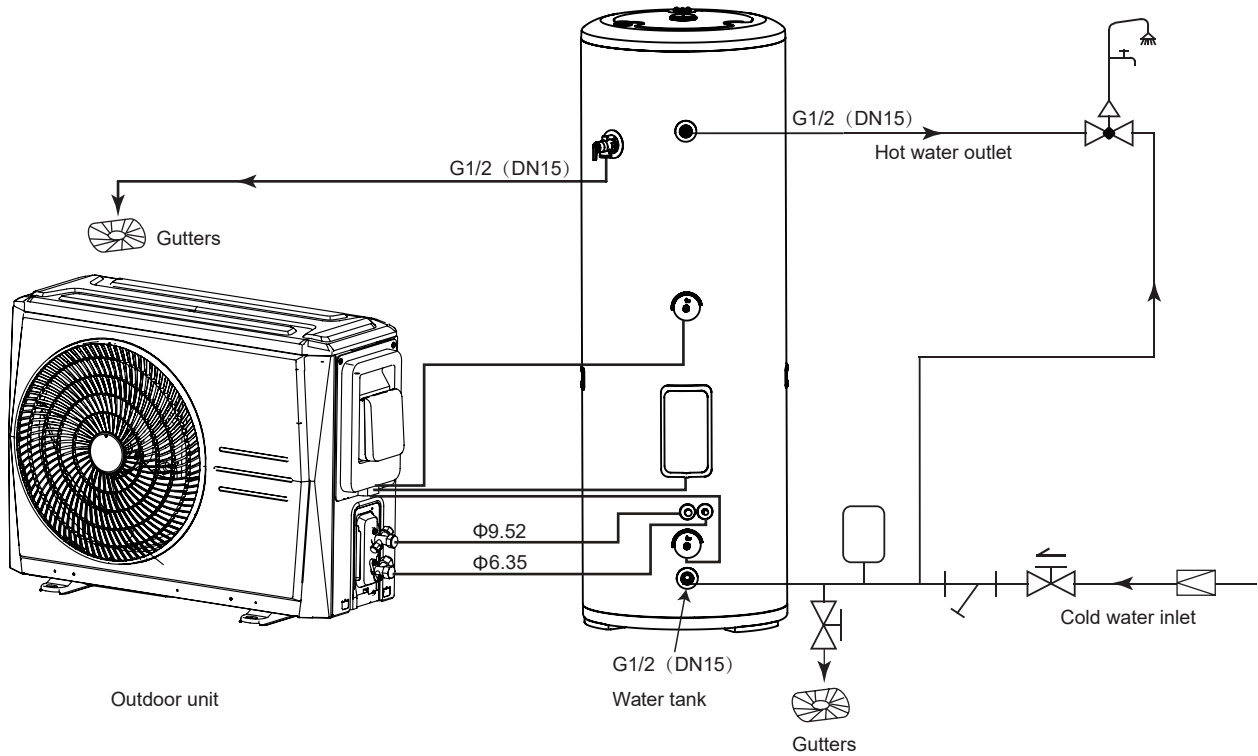

Name	Water use site	One-way stop valve (field supply)	Water mixing valve (field supply)	Shut valve (field supply)
Icon				
Name	Gutter	Expansion tank (field supply, suggest to install)	Y-type filter (40 meshes) (field supply)	Pressure reducing valve (field supply)
Icon				

### NOTE

- Water tank temperature can be set between 52°C and 60°C.
- Water inlet pressure must be between 0.15MPa and 0.5MPa.
- If below 0.15MPa, install a pump at the inlet.
- If above 0.5MPa, install a pressure reducing valve on the inlet pipe.
- Use thread seal tape when connecting water pipes and valves.
- If outlet water temperature exceeds user requirements, fit a mixing valve at the point of use.

# Installation

## PTR valve

- The valve body relief pressure is 850kPa, the relief temperature is 99°C, and the valve opening energy rating is 46kW. For further details, refer to certificate No: WMK26608.
- Tighten the PTR valve using a torque wrench set to 68 N·m. Apply sealant to the first three turns of the screw thread before installation. After installation, ensure the outlet of the drain pipe faces downwards, and that no more than three thread turns remain exposed.
- The PTR valve must be correctly installed before filling the water tank.

### ⚠ CAUTION

Do not operate the valve handle quickly, as this may cause water hammer and damage the valve.

- The PTR valve should be checked every six months to ensure it is not restricted. Take care, as hot water may discharge from the valve. The drain pipe should be properly insulated to prevent water inside the pipe from freezing in cold weather.

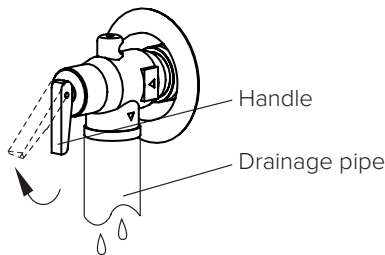

## Stop valve instruction

The general shape of the stop valve and the names of its parts are shown in the diagram.

### Functions of the stop valve:

- To stop the system while the unit is operating.
- To allow vacuuming and refrigerant charging when the water tank is connected to the outdoor unit.
- To stop the system and return refrigerant to the outdoor unit during maintenance.

### Opening and closing the stop valve:

- To open: Use a wrench to remove the bonnet. Insert an Allen key into the spool, turn the stop block anticlockwise, and then re-tighten the bonnet.
- To close: Use a wrench to remove the bonnet. Insert an Allen key into the spool, turn the stop block clockwise, and then re-tighten the bonnet.

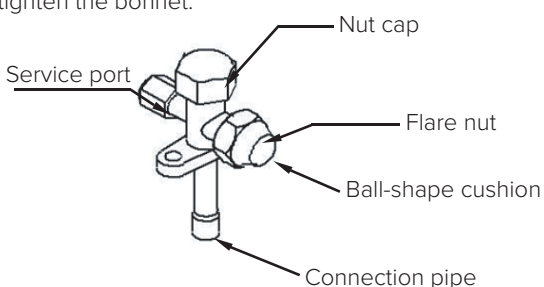

### ⚠ CAUTION

Before operating the water heater, ensure all stop valves are open.

When operating the valves, make sure there are no open flames or sparks present, to prevent the risk of explosion or ignition.

## Connection length and height difference requirements between the outdoor unit and water tank piping:

Max. length (m)	Max. height difference (m)	Standard length (m)	Standard height difference (m)
20	10	2	0

### 💡 NOTE

Hydraulic components may freeze during refrigerant removal. Drain heating water from the heat pump beforehand.

- Do not allow air, dust, or other impurities to enter the pipe system during installation.
- The connecting pipe should only be installed after both the indoor and outdoor units have been securely fixed in place.
- Keep the connecting pipe dry and ensure no moisture enters during installation.
- When connecting copper pipe, wrap it with thermal insulation material.
- If the required piping length exceeds the standard 2 metres, an extended pipe of the actual required length (including refrigerant) must be ordered with the delivery. No additional refrigerant is needed.

# Installation

## Quick connect couplings

### Unit connection sketch

- ① Re-tighten the valve using a torque wrench (tightening torque: 20 N-m).
- ② Connect the quick connector to the stop valve using a torque wrench (tightening torque: 20 N-m).
- ③ Open the stop valve.

### Leak detection

The following methods can be used to identify the source of a leak:

1. Audio detection: Larger leaks may be audible.
2. Touch detection: Place your hand near joints to feel for escaping gas.
3. Soapy water detection: Apply soapy water to a joint - small leaks will be indicated by the formation of bubbles.

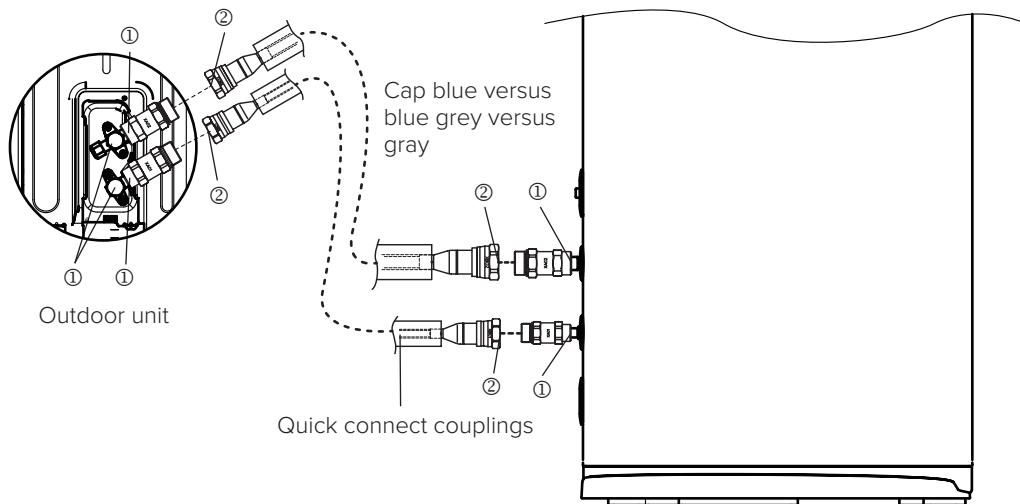

Quick connection	Quick connect couplings

# Electrical connection

## ⚠ CAUTION

- The heat pump must use a dedicated power supply with the rated voltage. If the supply voltage is unstable, a stabilised power supply should be used
- The external power supply must include an earth connection, linked to the earth wiring of both the indoor and outdoor units
- All wiring must be carried out by qualified personnel in accordance with the circuit diagram
- A residual current device (RCD) must be installed in accordance with national standards for electrical appliances
- An all-pole disconnection device with a contact separation of at least 3 mm must be installed
- Power supply cords and signal wires must be arranged correctly: separate high-current (power) and low-current (signal) wiring, and ensure they do not come into contact with pipes or valves
- Any RCD and associated power supply must be installed in a waterproof location indoors
- Do not cross-connect two wires. Signal wires must be shielded
- When power cords run parallel to control wires, place them in appropriate conduit and maintain adequate spacing between them
- When selecting power supply cords, refer to the relevant national standards and this manual. Outdoor power supply cords must comply with at least Type 57 of IEC 60245
- If the power supply cord is damaged, it must be replaced by a qualified professional to prevent danger
- Do not switch on the power until all wiring has been carefully checked.

## Power supply cords

Model \ Item	Power	Min. wire dia. (mm <sup>2</sup> ) (metal pipe synthetic resin pipe wire)		Manual switch(A)		Leakage protector	Max. E-heater Power(W)
		Successive length ≤30 m	Ground wire	Capacity	Fuse		
with AUX.	220-240 V~50Hz	2.5	2.5	20	16	30 mA below 0.1 sec	2 100
without AUX.		1.5	1.5				

## ⚠ CAUTION

- The specified power cable type for both the outdoor unit and the connection to the water tank is H07RN-F.
- The heat pump must be supplied by an individual power source (do not use a shared power supply device).
- The wire diameters shown in the table above are based on a voltage drop within 2%.
- If the cable length exceeds the values shown in the table, select the wire diameter according to the relevant standards.

# Electrical connection

## Water tank temperature sensor installation

Connect the water tank temperature sensor wire connector to the outdoor unit T5U and T5L connector.

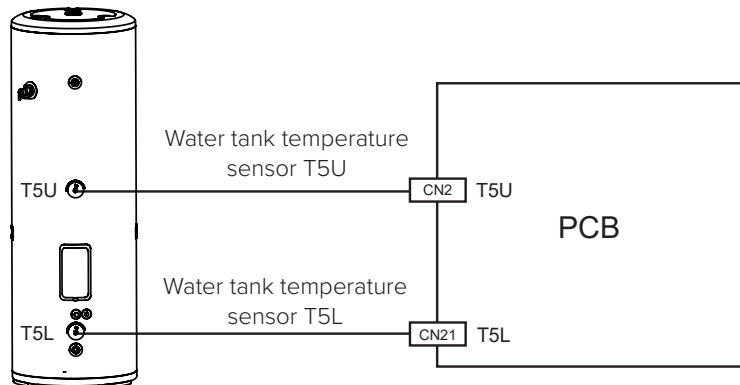

## Outdoor unit and AUX. power connection

### ⚠ CAUTION

If the water tank has the electric auxiliary heater(AUX.)function, please follow the steps below to connect the electric auxiliary heating power cord.

1. Remove the protective cover of the electric control box on the right side of the outdoor unit.

2. Connect the electric auxiliary heater power cable from the water tank to the corresponding terminal on the terminal block.

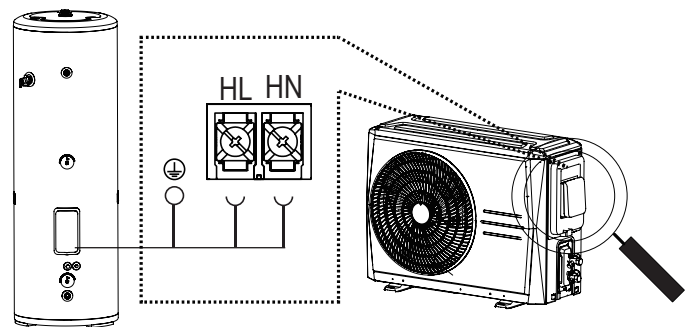
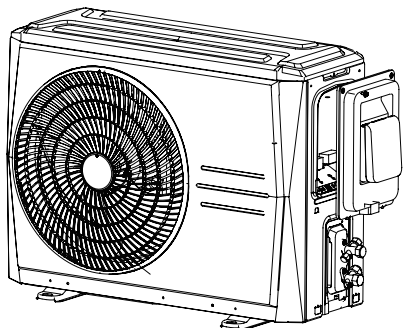

3. Outdoor unit power supply.

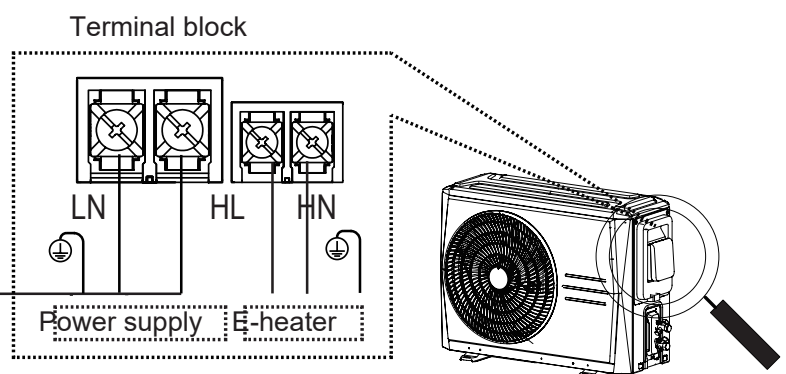
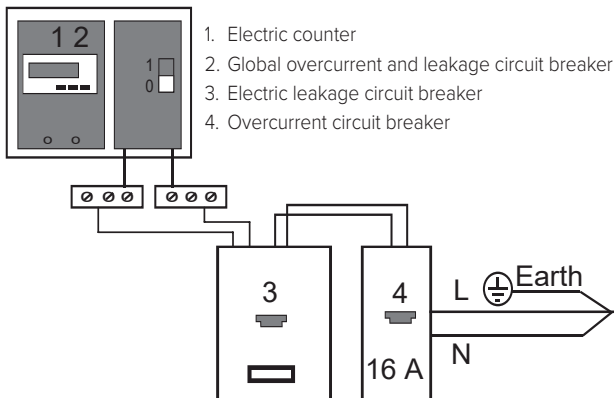

### ⚠ CAUTION

A leakage protector must be installed on the external power supply as shown. It must be located indoors or in a waterproof area.

The unit must not be started unless it is properly earthed.

# Electrical connection

## DIP switch settings

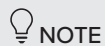

The picture shown is for reference only, actual product may vary.

means 0, means 1.

S1-1		1	Reserve
		0	Default
S1-2		1	Reserve
		0	Reserve
S1-3		1	First setting parameters
		0	Second setting parameters
S2-1		1	High temperature
		0	Default temperature
S2-2		1	User settings are valid in 24 hours by default
		0	User settings are always valid by default
S2-3		1	High demand
		0	Normal demand

# Check

















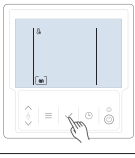

## NOTE

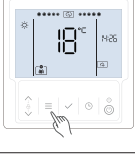
Before switching on the unit, observe the following recommendations:

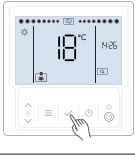
- Once installation and parameter settings are complete, ensure all sheet metal covers are securely fitted.
- The unit should only be serviced or maintained by qualified professionals.

For water tanks with an electric auxiliary heater, check the heater's condition using the method below before long-term operation. This will help prevent damage to the unit or personal injury.

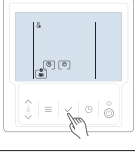

### Quality inspection of electric auxiliary heater

Description	Image	Comment
After the unit is powered on, press the power button  on the controller and the LED light will be lightened.		The unit must be installed in accordance with the relevant specifications. Before switching on the unit, ensure the water tank is completely filled to prevent damage to the electric auxiliary heater.
Press and hold the  button until the manual electric auxiliary heater (E-heater) icon  appears. Then press the   buttons to select the  icon (it will flash slowly).		If the controller is locked and the lock icon is displayed, press and hold the “+” buttons to unlock. The disappearance of the icon indicates that the controller has been successfully unlocked.
Press the  button again. The icon  will appear, indicating that the manual electric auxiliary heater function is now ON.		Press the button to switch the manual electric auxiliary heater function ON or OFF.
Press the  button to return to the main interface. If both the manual E-heater function icon and the E-heater operation status icon are displayed, the manual E-heater function is ON and the E-heater is operating. If the icons are not displayed, check that Steps 1 to 4 have been completed correctly.		
After the manual E-heater function is switched ON, wait 5 minutes for the E-heater to stabilise in the water-filled system. Check whether the leakage protection switch trips. If it does, immediately disconnect the power and contact qualified service personnel.		In this case, the electric heater usually needs to be replaced.
If no tripping occurs, unlock the controller and switch OFF the manual E-heater function. Then press and hold the  button to enter the E-heater function interface.		
After entering the E-heater function interface, press the  button again to cancel the manual E-heater function. The icon display will change from  to  .		
Press the  button to return to the main interface. The manual E-heater function icon and the E-heater operation status icon will no longer be displayed, indicating that the manual E-heater function has been switched OFF.		

### 6.2 System parameter check

If the unit fails or enters protection mode, the controller will display the corresponding error code. If multiple faults or protections occur, they will be displayed in order of occurrence. Additional parameters can also be viewed on the controller during checks.

## Error and other codes explanation

When the unit occurred any fault, the error code will be displayed at **88:88**, and alarm icon  will quickly flash, and cancel icon  will slowly flash, and buzzer will sound 3 times every 180 sec. Long press  for 3 sec. to cancel buzzer, but alarm icon and error code will quickly flash until the fault is removed.

### Error and Other Code Explanation

CODE	EXPLANATION
E0	There is not enough water in the water tank
E2	Communication malfunction between controller and main control board
E4	Water tank temperature sensor error (T5L)
E5	ODU heat exchanger temperature sensor error (T3)
E6	ODU ambient temperature sensor error (T4)
E9	Suction temperature sensor error (Th)
E8	E0 protection continuously occurs three times
EA	Discharge temperature sensor error (Tp)
EE	EEPROM chip error
EF	Clock chip error
EP	Leakage error of e-heater
P0	System low pressure protection (low pressure switch)
P1	System high pressure protection (high pressure switch)
P3	Over load protection of inverter compressor
P4	High discharge temperature (Tp) protection
PA	Low water temperature protection
bA	The ambient temperature exceeds the declared range (not an error)
bb	Low heat pump capacity
C7	High temperature protection of inverter module
CH	Over load protection of E-heater (16 A)
H1	Communication malfunction between main control board and inverter board
H4	Three times L0 protects
H6	The DC fan motor malfunction
H7	Voltage protection
HC	E-heater error (Current is less than 2 A when e-heater operating)
HF	Inverter module board EEPROM malfunction
HP	Smart Grid signal error
HH	10 times H6 in 2 hours
F1	DC bus low voltage protection
F2	Low super-heat of discharge protection
F6	Electric expansion valve joint fault
L0	Inverter over load protection
L1	Inverter high temperature protection
L2	DC bus high voltage protection
L3	Inverter module sampling abnormality
L4	Operating speed abnormality of compressor
L5	Phase loss protection of inverter
LA	Program of inverter module verification abnormality
Lb	PFC protection
d0	Oil returning (not an error)
d8	Remote shutdown (not an error)
db	Anti-freezing operating (not an error) for some unit
dF	Defrosting (not an error)

# Operations

## Characteristics of water heating – 3-minute protection

After shutdown, if the unit is restarted or the manual switch is turned on within a short period, the unit will not start immediately. The compressor includes a self-protection function and will delay start-up for 3 minutes.

## During operation

If the outdoor temperature is higher than normal, the fan motor will run at low speed or stop.

## Defrosting function during heating operation

- If frosting occurs during heating, the unit will automatically perform a defrost cycle to maintain heating efficiency. The cycle lasts approximately 2–7 minutes.
- During defrosting, the unit fan motor will stop.

## Protection devices

When a protection device is activated, the unit will stop, but the operating indicator on the wired controller will continue to blink. The display will show a fault code.

Protection devices may activate under the following conditions:

- a) Air inlet or outlet blocked.
- b) Voltage outside the operating range (more than  $\pm 10\%$  of 230 V).

## Start-up after long periods out of service

When starting the unit after a long period of disuse (including first-time start-up), rust-coloured water may flow from the tap. This is normal. Continue draining until the water runs clear.

## Power failure

- If a power failure occurs while the unit is operating, stop all operating actions.
- At the next start-up, the RUN indicator on the wired controller will blink slowly for several seconds to notify the user.
- Incorrect operation may occur if the unit is restarted during a power failure.

## Residual Current Circuit Breaker (RCCB)

- The outdoor unit must be connected to an RCCB. Install an RCCB between the user power supply and the outdoor unit.
- If the unit does not operate and power failure is not the cause, check the RCCB first.
- Before operating the RCCB, ensure the main power switch is turned off.

## Start/stop control

- The user can set the target water temperature and the dead band temperature via the wired controller.
- When the upper sensor in the water tank detects that the water temperature has fallen below the target temperature minus the dead band, the controller will start the heat pump.
- The heat pump will stop once the upper tank temperature reaches the set target temperature.

## Legionella control

- The unit will perform a weekly disinfection cycle (default: between 1:00 am and 6:00 am).
- During disinfection, the bottom tank sensor controls the heat pump to heat more than 90% of the tank water to above 60 °C and maintain this temperature for at least 32 minutes.
- During this cycle, the maximum tank outlet temperature will exceed 60 °C.

## Boost E-heater

- The E-heater is installed in the lower section of the tank and shares the same water temperature sensor as the heat pump.
- It operates in the following situations:
  - When ambient temperature is outside the heat pump's operating range ( $-15\sim 46^{\circ}\text{C}$ ).
  - When the water temperature falls below the target temperature minus the dead band.
  - When manually activated for occasional boost heating.
  - In emergencies, if the heat pump system malfunctions.

# Service and maintenance

## Checks to the area

Before beginning work on systems containing flammable refrigerants, safety checks are required to minimise the risk of ignition. The following precautions must be observed before carrying out repairs to the refrigeration system.

## Work procedure

All work must follow a controlled procedure to minimise the risk of flammable gas or vapour being present while the work is performed.

## General work area

- All maintenance staff and others in the local area must be informed of the nature of the work.
- Avoid working in confined spaces.
- Section off the area around the workspace.
- Ensure conditions are made safe by removing or controlling flammable materials.

## Checking for refrigerant leaks

- Use an appropriate refrigerant detector before and during work to ensure the technician is aware of any potentially flammable atmospheres.
- Leak detection equipment must be suitable for use with flammable refrigerants (non-sparking, adequately sealed, or intrinsically safe).

## Fire extinguisher availability

- If hot work is required on refrigeration equipment or associated parts, a suitable fire extinguisher must be available.
- Keep a dry powder or CO<sub>2</sub> extinguisher next to the charging area.

## No ignition sources

- Do not use ignition sources near pipework that contains or has contained flammable refrigerant.
- Prohibit cigarette smoking and keep all potential ignition sources well away from the installation, repair, removal, or disposal area.
- Survey the area before work to ensure no ignition hazards are present.
- Display NO SMOKING signs.

## Ventilated area

- Work must be carried out in the open or in a well-ventilated space.
- Ventilation must continue throughout the work to safely disperse any released refrigerant, preferably exhausting to the outside atmosphere.

## Checks to refrigeration equipment

- Replacement electrical components must be suitable for their intended purpose and meet the correct specifications.
- Always follow the manufacturer's maintenance and service guidelines.
- If in doubt, consult the manufacturer's technical department.
- The following checks apply to systems using flammable refrigerants.

## Checks to electrical devices

- Repair and maintenance of electrical components must include initial safety checks and inspection.
- Do not connect power if a fault exists that could compromise safety.
- If a fault cannot be corrected immediately but operation must continue, implement a safe temporary solution and notify the equipment owner.
- Initial safety checks include confirming that:
  - The refrigerant charge size matches the room size where refrigerant-containing parts are installed.
  - Ventilation machinery and outlets operate correctly and are unobstructed.
  - Secondary circuits in indirect systems are free of refrigerant.
  - Equipment labels and markings are visible and legible. Replace or correct any illegible markings.
  - Refrigeration pipes and components are not exposed to corrosive substances unless made from corrosion-resistant materials or suitably protected.
  - Capacitors are safely discharged to prevent sparking.
  - No live electrical components or wiring are exposed during charging, recovery, or purging.
  - Earth bonding continuity is maintained.

## Repairs to sealed components

a) Before repairing sealed components, disconnect all electrical supplies from the equipment before removing sealed covers. If it is absolutely necessary to maintain an electrical supply during servicing, a permanently operating leak detector must be placed at the most critical point to provide warning of a potentially hazardous situation.

b) Take particular care when working on electrical components to ensure that the casing is not altered in a way that reduces protection. This includes:

- Preventing damage to cables.
- Avoiding excessive connections.
- Ensuring terminals meet the original specification.
- Preventing damage to seals.
- Correctly fitting glands.

Ensure the apparatus is mounted securely.

Check that seals or sealing materials are intact and effective in preventing the ingress of flammable atmospheres. Replacement parts must comply with the manufacturer's specifications.

Note: The use of silicone sealant may reduce the effectiveness of some leak detection equipment.

Intrinsically safe components do not need to be isolated before work.

## Repair of intrinsically safe components

- Do not apply permanent inductive or capacitive loads to the circuit unless it is confirmed that the permissible voltage and current will not be exceeded.
- Only intrinsically safe components may be worked on live in the presence of a flammable atmosphere.
- Use test apparatus of the correct rating.
- Replace components only with those specified by the manufacturer. Substituting other parts may ignite leaked refrigerant.

# Service and maintenance

## Cabling

Check that cabling is not subject to:

- Wear or corrosion.
- Excessive pressure.
- Vibration.
- Sharp edges.
- Other adverse environmental effects.

Also consider long-term effects such as ageing or continual vibration from compressors or fans.

## Detection of flammable refrigerants

Never use potential ignition sources when searching for refrigerant leaks. A halide torch (or any detector using a naked flame) must not be used.

## Leak detection methods

- Approved electronic leak detectors may be used for flammable refrigerants. Ensure sensitivity is adequate and recalibrate as needed. (Calibration must be done in a refrigerant-free area.)
- Detectors must not be ignition sources and must be suitable for the refrigerant in use.
- Leak detection equipment must be set to a percentage of the refrigerant's LFL (Lower Flammability Limit), with a maximum of 25%.
- Leak detection fluids may be used, but detergents containing chlorine must be avoided, as chlorine may react with refrigerant and corrode copper pipework.
- If a leak is suspected, extinguish all naked flames.
- If brazing is required:
  - Recover all refrigerant from the system or isolate it in a section remote from the leak using shut-off valves.
  - Purge the system with oxygen-free nitrogen (OFN) before and during brazing.

## Removal and evacuation

When breaking into the refrigerant circuit for repairs or other purposes, follow best practice to account for flammability:

1. Recover refrigerant into approved recovery cylinders.
  2. Purge the circuit with inert gas.
  3. Evacuate the system.
  4. Purge again with inert gas.
  5. Open the circuit by cutting or brazing.
- Flush the system with OFN to render it safe. This may need to be repeated several times.
  - Do not use compressed air or oxygen.
  - Flushing is achieved by breaking the vacuum with OFN, filling to working pressure, venting to atmosphere, and pulling down to a vacuum. Repeat until no refrigerant remains in the system.
  - For the final OFN charge, vent the system to atmospheric pressure before beginning work. This is essential if brazing pipework.
  - Ensure the vacuum pump outlet is clear of ignition sources and that adequate ventilation is provided.

## Charging procedures

In addition to conventional charging procedures, the following requirements must be observed:

- Prevent contamination between different refrigerants when using charging equipment.
- Keep hoses or lines as short as possible to minimise refrigerant volume.
- Cylinders must be kept upright.
- Ensure the refrigeration system is earthed before charging.
- Label the system once charging is complete (if not already labelled).
- Take extreme care not to overfill the system.
- Before recharging, pressure-test the system with oxygen-free nitrogen (OFN).
- Leak test the system after charging but before commissioning. A follow-up leak test must be conducted before leaving the site.

## Decommissioning

Before decommissioning, technicians must be fully familiar with the equipment and its details. All refrigerants must be safely recovered. Take an oil and refrigerant sample before starting work in case analysis is required prior to re-use. Electrical power must be available before starting.

Steps:

- a) Familiarise yourself with the equipment and its operation.
- b) Electrically isolate the system.
- c) Ensure:
  - Mechanical handling equipment is available (if required) for refrigerant cylinders.
  - All personal protective equipment (PPE) is available and used correctly.
  - Recovery is supervised at all times by a competent person.
  - Recovery equipment and cylinders comply with the relevant standards.
- d) Pump down the refrigerant system if possible.
- e) If vacuum recovery is not possible, use a manifold to remove refrigerant from multiple points of the system.
- f) Place cylinders on weighing scales before recovery.
- g) Operate the recovery machine according to the manufacturer's instructions.
- h) Do not overfill cylinders (maximum 80% liquid volume).
- i) Do not exceed the maximum working pressure of the cylinder.
- j) Once cylinders are filled, remove them and the equipment from the site promptly and close all isolation valves.
- k) Recovered refrigerant must not be reused in another system unless it has been cleaned and verified.

## Labelling

Equipment must be labelled to confirm it has been decommissioned and emptied of refrigerant.

Labels must include a date and signature.

Labels must also clearly state that the equipment contains flammable refrigerant.

# Service and maintenance

## Recovery

- Always remove refrigerants safely during service or decommissioning.
- Only use approved recovery cylinders. Ensure the correct number of cylinders are available to hold the full system charge.
- Recovery cylinders must:
  - Be designated for the specific refrigerant.
  - Be fitted with pressure relief and shut-off valves in good condition.
- Empty recovery cylinders must be evacuated and, if possible, cooled before recovery.
- Recovery equipment must be:
  - In good working order.
  - Suitable for flammable refrigerants.
  - Supplied with operating instructions.
- Calibrated weighing scales must be available and in good order.
- Hoses must be leak-free, fitted with disconnect couplings, and in good condition.
- Inspect recovery machines and associated electrical components to ensure they are sealed and ignition-proof before use.
- Return recovered refrigerant to the supplier in the correct recovery cylinder, with a Waste Transfer Note.
- Do not mix refrigerants in recovery equipment or cylinders.
- If compressors or compressor oils are removed, evacuate them to remove residual refrigerant. Only use electric heating on the compressor body to accelerate this process.
- Drain oil from the system safely.

## Transportation, marking, and storage of units

**Transport:** Equipment containing flammable refrigerants must comply with transport regulations.

**Marking:** Equipment must be clearly marked in compliance with local requirements.

**Disposal:** Equipment using flammable refrigerants must be disposed of according to national regulations.

### Storage:

- Store equipment as per the manufacturer's instructions.
- Packed (unsold) equipment must be stored in protective packaging designed to prevent mechanical damage that could cause refrigerant leaks.
- The maximum number of units permitted in storage is subject to local regulations.

## Confirmation before running

1. Check that the earth (ground) wire is intact and has not become loose or disconnected.
2. Switch on the machine only after confirming that all connections are secure and compliant.

## Troubleshooting when abnormal situations occur

Before requesting service or repair, check the following points:

- Non-mechanical malfunctions
  1. Water oozing from the safety valve pressure relief opening
    - During water heating, cold water expands as it is heated. A small amount of water discharge is normal. Do not block the outlet, as it is a safety feature.
    - If a large amount of water flows continuously, the safety valve is faulty. Stop using the unit and replace the valve.
  2. Long heating time for a full tank of water
    - In winter, when the ambient temperature is low (around 0 °C), heating efficiency decreases and heating time will be longer.
    - If hot water is required, switch the unit on earlier to allow additional heating time.
- Need to check
  1. Unit starts or stops automatically
    - Check if the timer has been set incorrectly.
  2. Unit not working
    - Confirm the power supply is switched on.
    - Check that the manual switch is on.
    - Inspect whether the fuse has blown.
    - Check if the protection device has been activated (indicator lights).
    - Confirm it is within the timer "ON" period (operation lamp lit).
  3. Poor heating performance
    - Check if the air inlet or outlet is blocked.

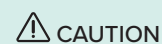

Stop operation, switch off power, and contact your dealer or service centre if:

- ON/OFF operation fails.
- Fuse or RCCB trips frequently.

Before long-term shutdown:

- Drain the tank and pipes, and close all valves.

Before restarting after long-term shutdown:

- Ensure air inlets and outlets are not blocked.
- Check pipes, valves, and joints for damage or leaks; replace if necessary.
- Inspect the anode protection material every six months and replace if depleted.

# Service and maintenance

## After sales service

In case of malfunction, switch off the power and contact the after-sales service centre or technical support. For details, refer to the User Service Guide.

## Important information for the used refrigerant

This product contains flammable gas and must not be installed in an enclosed space.

Refrigerant type: R290

GWP (Global Warming Potential): 3

Factory charge	
Refrigerant/kg	tonnes CO <sub>2</sub> equivalent
0.47	0.00141



**WARNING**

### Frequency of refrigerant leak checks

1. Equipment containing fluorinated greenhouse gases equivalent to 5–50 tonnes of CO<sub>2</sub>: check at least every 12 months, or every 24 months if a leak detection system is installed.
2. Equipment containing fluorinated greenhouse gases equivalent to 50–500 tonnes of CO<sub>2</sub>: check at least every 6 months, or every 12 months if a leak detection system is installed.
3. Equipment containing fluorinated greenhouse gases equivalent to 500 tonnes of CO<sub>2</sub> or more: check at least every 3 months, or every 6 months if a leak detection system is installed.
4. Non-hermetically sealed equipment charged with fluorinated greenhouse gases may only be sold to the end user if installation will be carried out by a certified undertaking.
5. Installation, operation, and maintenance must only be performed by certified personnel.

## Water quality limitations

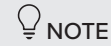

**NOTE**

If the water quality does not meet the requirements in the table below, please contact the supplier for advice.

PH Value	Total Hardness	Electrical conductivity
6.5-8.0	50 ppm	< 200µS/cm(25°C)
Sulphate Ion	Silicon	Iron Content
<50ppm	<30ppm	<0.3ppm
Sulfide Ion	Chloride Ion	Ammonia Ion
None	<50ppm	None
Sodium Ion	Calcium Ion	-
None	<50ppm	-

## About maintenance

### About refrigerant recovery

About refrigerant recovery If the water tank needs to be replaced, the refrigerant must be returned to the unit. The procedure for refrigerant recovery is as follows:

1. Switch on the unit's controller and activate the refrigerant recovery function, following the controller's operating instructions.
2. Once the unit begins blowing out hot air, close the liquid-side refrigerant stop valve (the smaller one).
3. When the air being expelled is close to ambient temperature, close the gas-side refrigerant stop valve (the larger one).
4. Finally, turn off the power. The refrigerant recovery process is then complete.

# Service and maintenance

## About vacuuming

### Purpose

Vacuum drying must be carried out to remove moisture and non-condensable gases from the system. Removing moisture prevents ice formation and the oxidisation of copper piping or other internal components. Ice particles in the system can cause abnormal operation, while oxidised copper particles may lead to compressor damage. Non-condensable gases in the system can result in pressure fluctuations and reduced heat exchange performance.

### Procedure

#### CAUTION

- When installing for the first time, vacuuming is not required as the water tank and connecting pipes (included with the accessories) are pre-filled with refrigerant.
- Vacuuming is only required after completing field maintenance of the refrigerant system, provided the outdoor unit, water tank, and connecting pipes have not been disconnected.
- When vacuuming after maintenance, ensure there are no open flames or sparks nearby to prevent explosion or ignition.

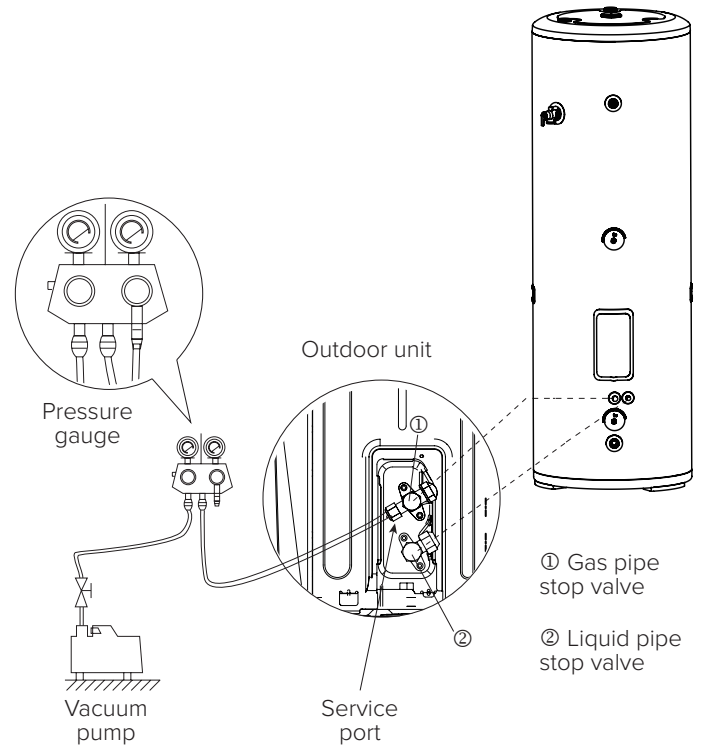

## Service and maintenance

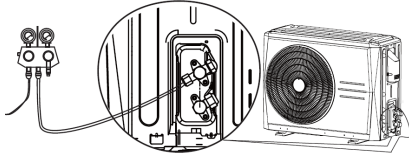
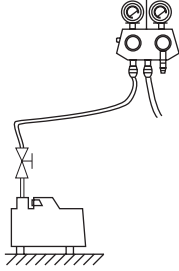
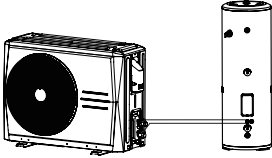
Description	Image	Comment
Connect the hose from the pressure gauge (low-pressure side) to the gas pipe stop valve on the outdoor unit.		Before performing vacuum drying, make sure that all the outdoor unit stop valves are firmly closed.
Connect the hose to the vacuum pump.		<p>1. Mixing of pump lubricant with compressor oil may cause compressor malfunction. To prevent vacuum pump lubricant from seeping into the piping system, a one-way valve must be used.</p> <p>2. It is recommended to use a vacuum pump with a discharge capacity greater than 4 L/s and a precision level of 0.02 mmHg.</p>
Connect the outdoor unit stop valve to water tank connection		
Start the vacuum pump, then open the pressure gauge valves to begin evacuating the system.		
After 15-20 minutes, close the pressure gauge valves.		
After a further 5 to 10 minutes check the pressure gauge. If the gauge is no change, then vacuum drying is OK. If the gauge has returned to zero, check for leakages in the refrigerant piping, then fix them.		
After fixing leaks, reopen the pressure gauge valves and continue vacuum drying until a pressure difference of at least 756 mmHg is reached, then maintain vacuum drying for a further 20 minutes.		
Close the pressure gauge valves and then stop the vacuum pump.		
After 1 hour, check the pressure gauge. If pressure is stable, the procedure is complete; if it has increased, check for leaks.		After vacuum drying, leave the hoses connected between the pressure gauge and the outdoor unit stop valves to prepare for refrigerant charging.

### Refrigerant charge

If there is no refrigerant in the system after maintenance, the refrigerant must be recharged once the vacuum pumping operation has been completed.

The refrigerant charge should be calculated as follows:

- For pipe lengths of less than 2 metres, the required refrigerant charge is 470g.
- For pipe lengths greater than 2 metres, an additional 10g of refrigerant per metre of extra pipe length must be added.





## After sales service

If your hot water heater can not operate normally, turn off the unit and cut off the power supply at immediately.

Contact your service center or technical department.

[emerald.com.au/contact](https://emerald.com.au/contact)

**Emerald Energy Pty Ltd**

ABN 86 632 172 368

L2, 12a Rodborough Road Frenchs Forest NSW 2086