

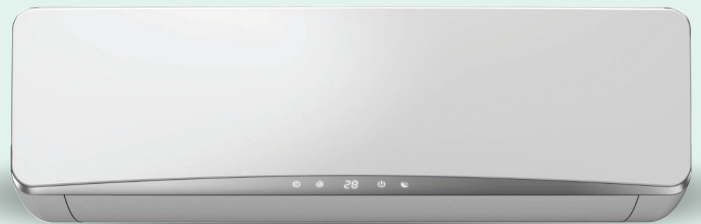

Troubleshooting and service manual

Air Conditioning Multi-Head Ultra Indoor Unit

ACV28W, ACV36W, ACV45W,
ACV56W, ACV71W, ACV84W

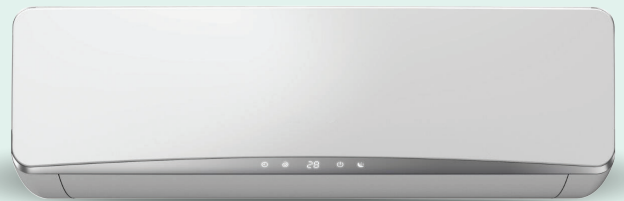

IMPORTANT NOTICE

Please read this manual before installing the product and retain for future use. Not following the instructions may result in the product not functioning as intended.

Installer information

Installer company:

Contact number:

Installer full name:

Install date:

Notes:

Important information

- Emerald pursues a policy of continuing improvement in design and performance of products. We reserve the right to change specifications without notice.
- Emerald cannot anticipate every possible circumstance that might involve a potential hazard.
- This heat pump air conditioner is designed for standard air conditioning only. This unit is not intended for purposes such as drying clothes, storing food, or any other process beyond standard heating or cooling.
- The installer and system specialist shall secure safety against leakage according to local regulations or standards. The following standards may be applicable if local regulations are not available. British Standard, BS4434 or Japan Standard, KHKS0010.
- No part of this manual may be reproduced without written permission.
- Signal words (DANGER, WARNING and CAUTION) are used to identify levels of hazard seriousness. Definitions for identifying hazard levels are provided below with their respective signal words.

DANGER

Immediate hazards that WILL result in severe personal injury or death.

WARNING

Hazards or unsafe practices that COULD result in severe personal injury or death.

CAUTION

Hazards or unsafe practices that COULD result in minor personal injury or product or property damage.

NOTE

Useful information for operation and/or maintenance.

- It is assumed that this heat pump air conditioner will be operated and serviced by English speaking people. If this is not the case, safety, caution and operating signs should be added in the native language.
- If you have any questions, contact your distributor or dealer of Emerald.
- This manual gives a common description and information for this heat pump air conditioner which you operate as well as for other models.
- Please refer to Section 1.2 for specified operation range, to which the heat pump air conditioner units have been designed.

This manual should be considered as a permanent part of the air conditioning equipment and should remain with the air conditioning equipment.

Correct disposal



This marking indicates that this product should not be disposed with other household wastes. To prevent possible harm to the environment or human health from uncontrolled waste disposal, recycle it responsibly to promote the sustainable reuse of material resources. To return your used device, please use the return and collection systems or contact the retailer where the product was purchased. They can take this product for environmentally safe recycling.

Checking product received

- Upon receiving this product, inspect it for any shipping damage. Claims for damage, either apparent or concealed, should be filed immediately.
- Check the model number, electrical characteristics (power supply, voltage and frequency) and accessories to determine if they are correct.

The standard utilisation of the unit shall be explained in these instructions. Therefore, the utilisation of the unit other than those indicated in these instructions is not recommended.

Please contact your local agent, as the occasion arises.

Emerald's liability shall not cover defects arising from the alteration performed by a customer without Emerald's consent in a written form.

Emerald is committed to continuous product improvement. We reserve the right, therefore, to alter the product information at any time and without prior announcement.

Contents

Safety summary	5
Necessary tools for installation	6
Transport and handling	
Transporting the indoor unit	7
Handling the indoor unit	7
Installation safety	8
General data	
Product specifications	9
Dimensional data	10
Sound data	13
Temperature data	14
Component data	17
Refrigerant cycle	18
Electrical data	19
Indoor unit installation	
Factory supplied accessories	20
Initial check	21
Installation of mounting bracket onto wall	21
Mounting the indoor units	24
Removing the flat panel	25
Install the flat panel	25
Refrigerant piping work	
Piping materials	26
Piping connection	26
Drain piping	28
Electrical wiring	
General check	29
Electrical wiring connection	29
Electrical wiring diagram	30
Test run	32
Field setting	
Field minimum wire sizes for power source	33
Setting of dip switches	33
Setting the filter indication interval	35
Indoor unit address	36
Functions	
Setting automatic swing louver	38
Automatic control	38
Cleaning and troubleshooting	
Filter cleaning	39
Troubleshooting	39

Important notice: Please read and keep this manual carefully before installing this product. Failure to do so may result in the product not working according to its design.

Safety summary

Safety Summary

DANGER

- Never pour water into the indoor or outdoor units. These products are equipped with electrical parts. If poured, it will cause a serious electrical shock.
- Do not touch or adjust safety devices inside the indoor or outdoor units. If these devices are touched or readjusted, it may cause a serious accident.
- Ensure the main power supply is switched OFF before accessing internal components.

WARNING

- Refrigerant leakage can cause difficulty with breathing due to insufficient air. If leakage occurs, turn OFF the main switch and contact your service contractor.
- Do not use any sprays such as insecticide, lacquer, hair spray or other flammable gases within approximately 1m (3.3ft.) from the system.
- If earth leakage breaker (ELB) or fuse is often activated, stop the system and contact your service contractor.

CAUTION

- The appliance is not to be used by children or person with reduced physical, sensory or mental capabilities, or lack of experience and knowledge, unless they have been given supervision or instruction concerning use of the appliance by a person responsible for their safety.
- Children should be supervised that they do not play with the appliance.
- The appliance should not be installed in the laundry.

Necessary tools

Necessary tools for installation

Handsaw	Wrench
Phillips head screwdriver	Charging cylinder
Vacuum pump	Manifold gauge
Refrigerant gas hose	Cutter for wires
Megohmmeter	Gas leak detector
Copper pipe bender	Spirit level
Manual water pump	Clamper for solderless terminals
Pipe cutter	Hoist (for indoor unit)
Brazing kit	Ammeter
Hexagon wrench	Voltage meter

NOTE

Please use tools or devices exclusively for R410A when contacting with R410A is inevitable.
Do not mix with other refrigerants.

Transportation and handling

Transportation the indoor unit

Transport the product as close to the installation location as possible before unpacking.

CAUTION

Do not put any materials on the product.

Handling the indoor unit

WARNING

Do not insert any foreign objects into the indoor unit. Before installation and test run, check to ensure the unit is free of any foreign objects. Failure to do so may result in fire, malfunction, or other hazards.

CAUTION

Be careful not to damage on insulation materials of unit's surface when lifting.

Installation safety

Installation

DANGER

Do not install the indoor unit in a flammable environment to avoid a fire or explosion.

WARNING

- Check to ensure that the ceiling slab is strong enough. Otherwise, the indoor unit may fall down.
- Do not install the indoor unit outdoors. Otherwise, an electric hazard or electric leakage will occur.

It is recommended that indoor units be installed at least 2.5 meters above the floor level.

General data

Product specifications

Indoor unit type		Wall Mounted Type					
Emerald model		ACV28W	ACV36W	ACV45W	ACV56W	ACV71W	ACV84W
Power supply		AC 1φ,220~240V/50Hz; AC 1φ,220V/60Hz					
Nominal cooling capacity	kW	2.8	3.6	4.5	5.6	7.1	8.4
Nominal heating capacity	kW	3.6	4.0	5.4	6.7	8.2	8.4
Rated cooling power consumption	W	30	40	30	40	40	80
Rated heating power consumption	W	30	40	40	40	40	80
Sound pressure level (overall scale)	dB(A)	36/35/33/32/30/28	38/35/33/32/30/28	38/37/36/32/31/29	40/38/36/35/33/31	45/42/41/38/35/31	50/48/45/41/36/33
Refrigerant	R410A (Nitrogen charged in case of corrosion)						
Dimension (H×W×D)	mm	270×845×203		315×960×230	315×1120×230		
Net weight	kg	9.5		13	14.5		
Gross weight	kg	13		17.5	19		
Indoor fan air flow rate	m ³ /h	590/550/520/490/ 450/420	620/550/520/490/ 450/420	690/660/620/540/ 520/480	970/900/850/800/ 730/690	1200/1080/1020/ 900/800/700	1400/1320/1200/ 1020/852/732
Piping connection	Flare-nut connection (with flare nuts)						
Liquid line	mm	Ø6.35mm		Ø6.35mm	Ø9.53mm		
Gas line	mm	Ø9.53mm		Ø12.7mm	Ø15.88mm		
Condensate drain	mm	VP16					
Packing dimension (H×W×D)	mm	375×943×310		430×1058×328	430×1223×328		
Packing volume	m ³	0.11		0.15	0.17		
Standard accessories	Wall mounting bracket						

NOTES:

1. The nominal cooling capacity and heating capacity are based on following conditions:

Cooling Operation Conditions

Indoor Air Inlet Temperature: 27°C DB (80°F DB)

19°C WB (66°F WB)

Outdoor Air Inlet Temperature: 35°C DB (95°F DB)

Heating Operation Conditions

Indoor Air Inlet Temperature: 20°C DB (68°F DB)

Outdoor Air Inlet Temperature: 7°C DB (44°F DB)

6°C WB (42°F WB)

Piping Length: 7.5m(2.6ft.)

Piping Lift: 0m(0ft.)

2. The sound pressure level is based on following conditions:

0.8m(2.6ft.) below the unit and 1m(3.3ft.) in front of the unit.

The above data were measured in an anechoic chamber so that reflected sound should be taken into consideration in the field.

The above noise values are measured under the condition of air supply.

General data

Dimensional data

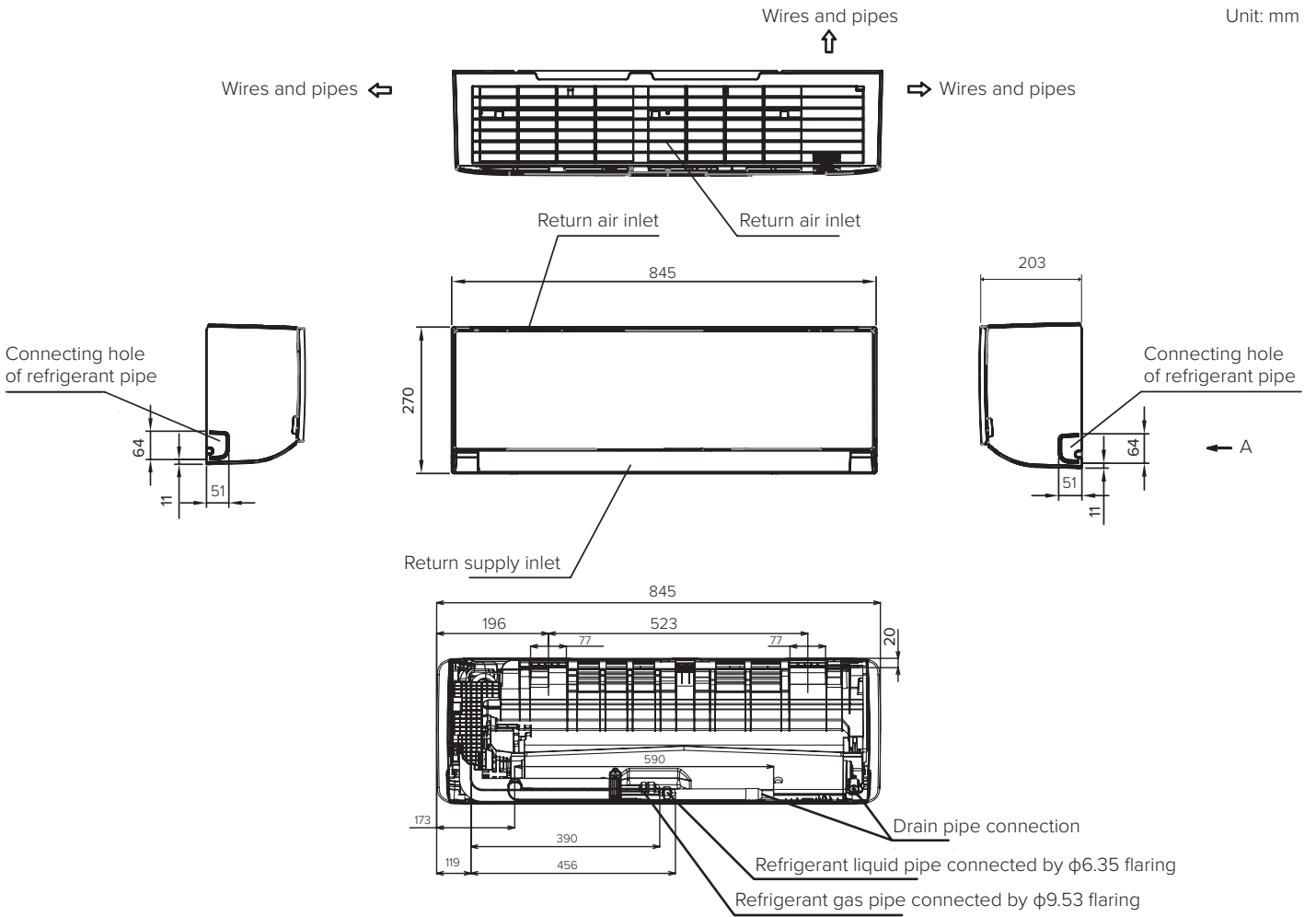

ACV28W and ACV36W Indoor units

General data

Dimensional data

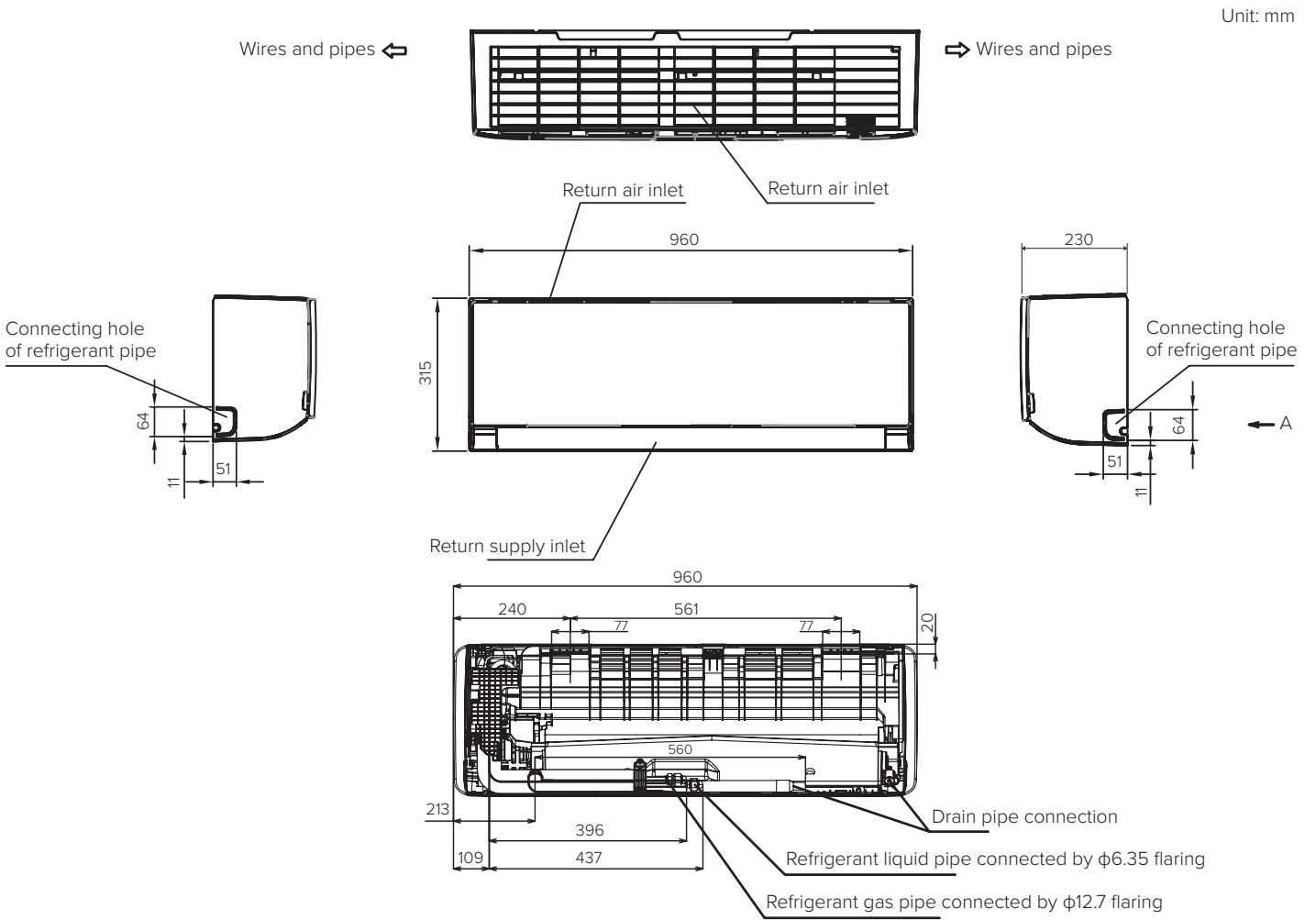

ACV45W Indoor unit

General data

Dimensional data

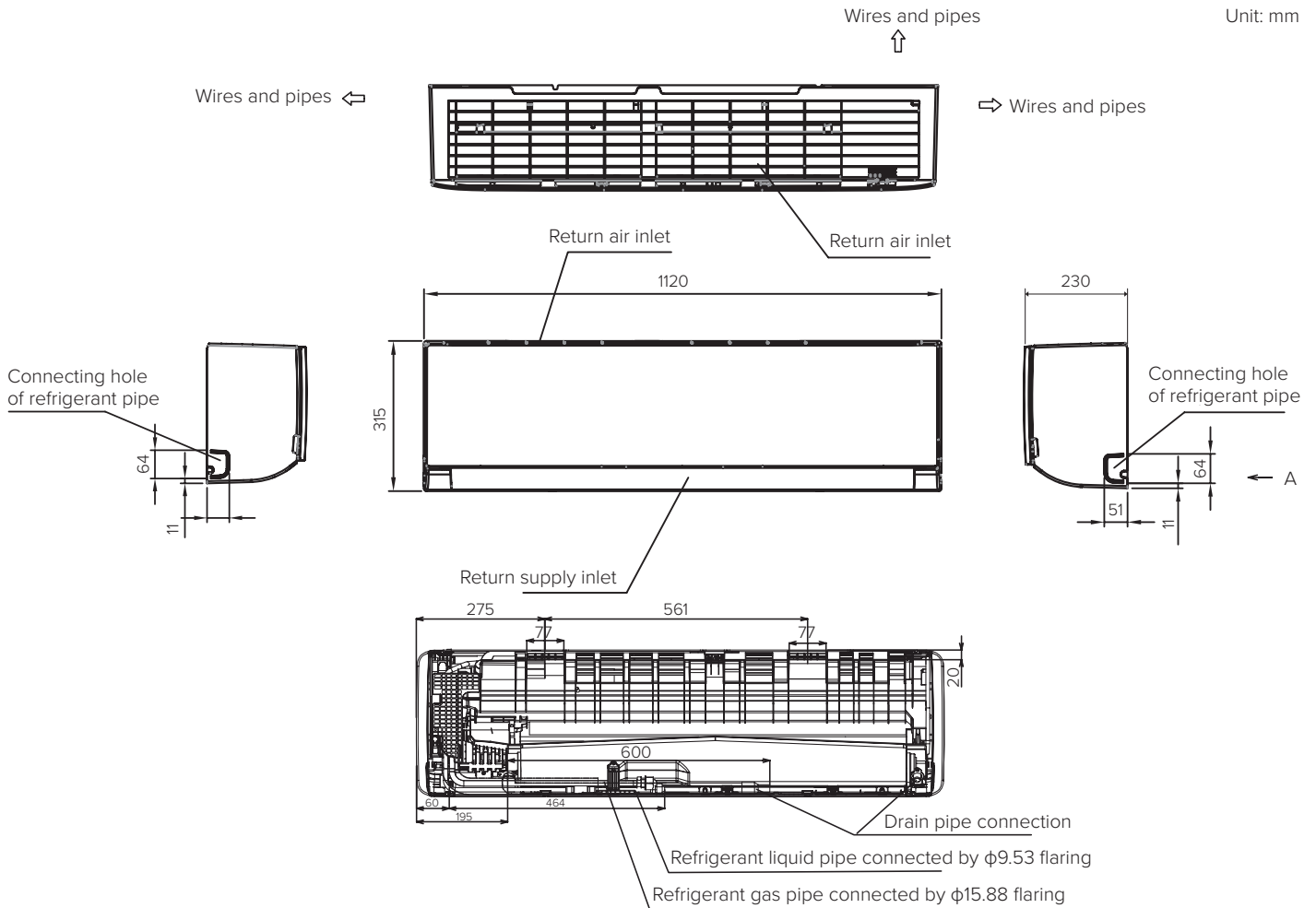

ACV56W, ACV71W and ACV84W Indoor units

Selection data

Service space

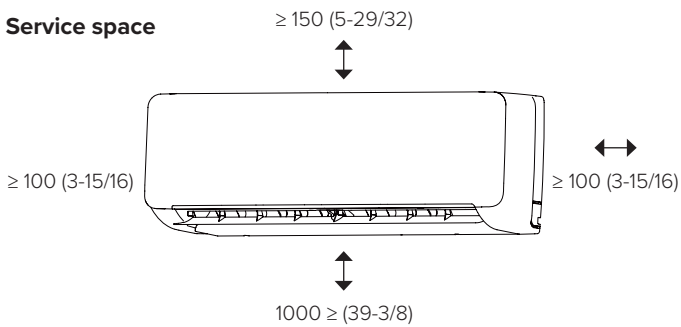

Operation and maintenance space. Unit: mm (in.)

Sensible Heat Factor (SHF)

The sensible heat factor of indoor units at each fan speed (Hi, Me, Lo) is given in the table below.

Indoor Unit Model	SHF					
	Super-Hi	Hi	Me	Lo	Super-Lo	Mute
ACV28W	0.70	0.69	0.69	0.68	0.67	0.66
ACV36W	0.71	0.69	0.69	0.68	0.67	0.66
ACV45W	0.71	0.711	0.70	0.69	0.69	0.68
ACV56W	0.71	0.70	0.70	0.69	0.68	0.68
ACV71W	0.74	0.73	0.72	0.70	0.69	0.69
ACV84W	0.77	0.76	0.74	0.72	0.70	0.69

General data

Sound data

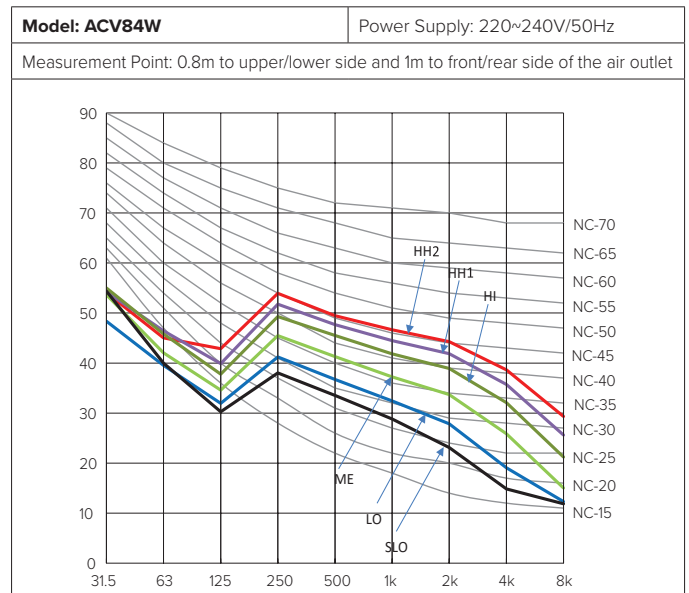
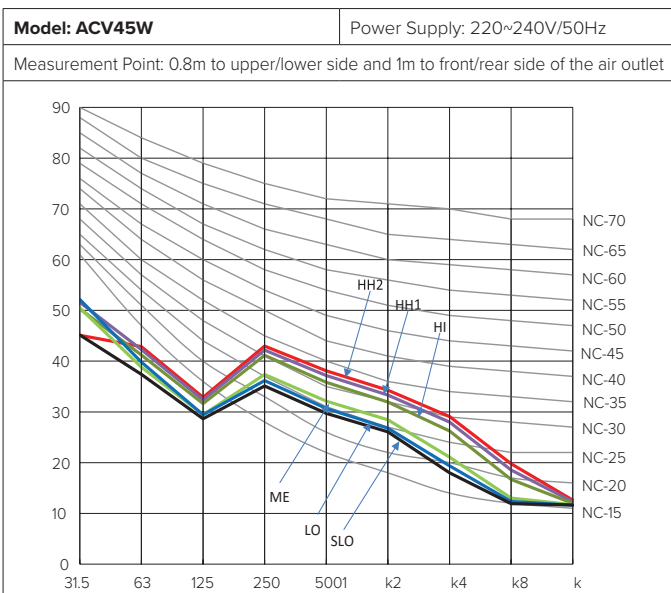
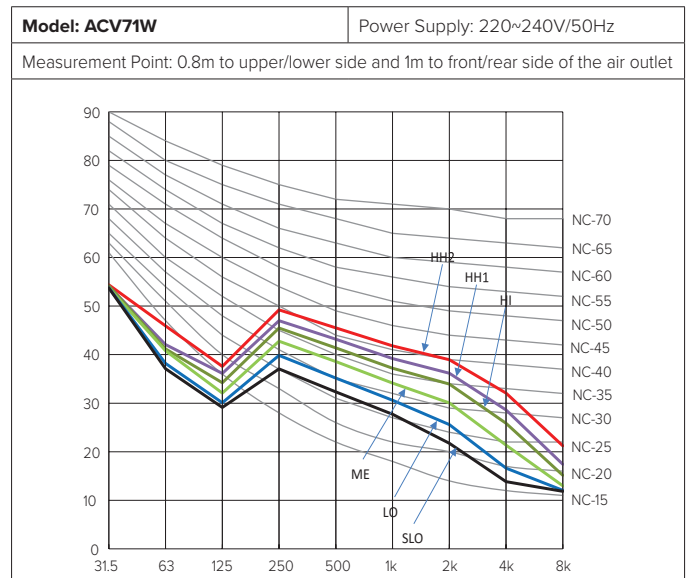
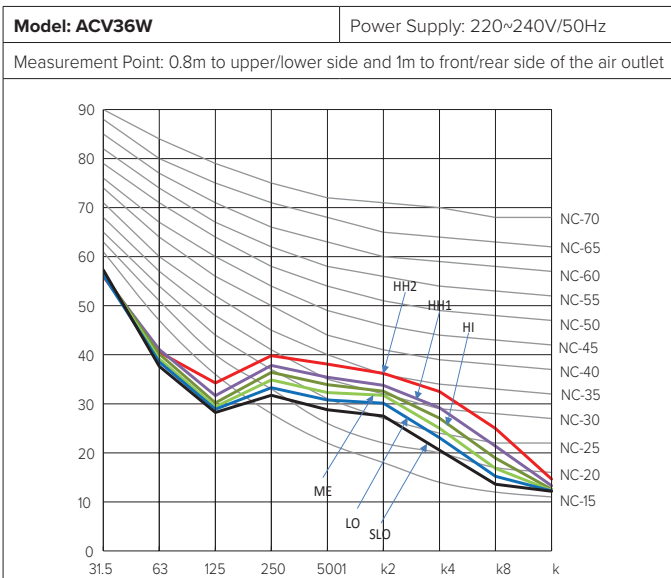
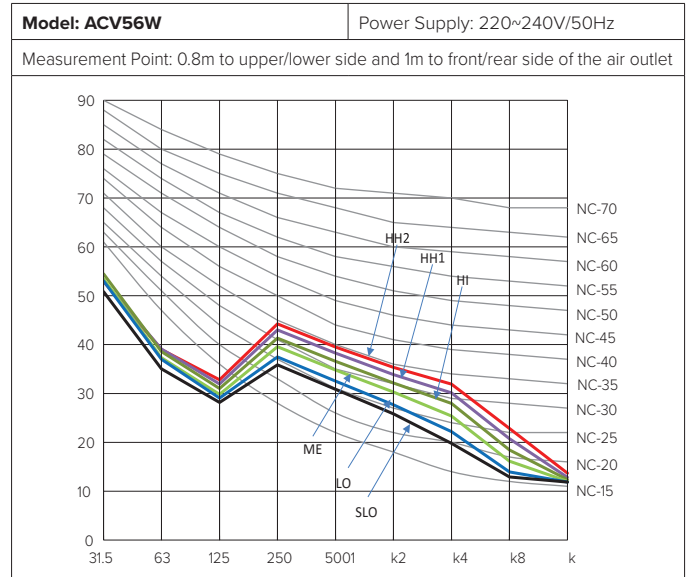
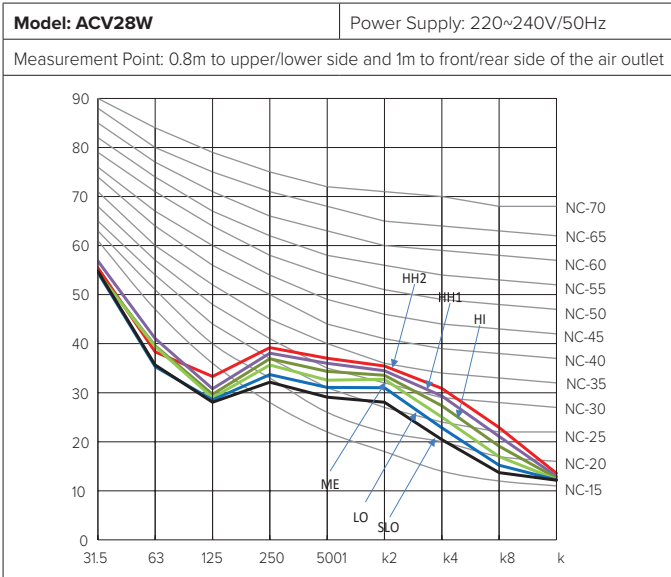

General data

Temperature data

Cooling

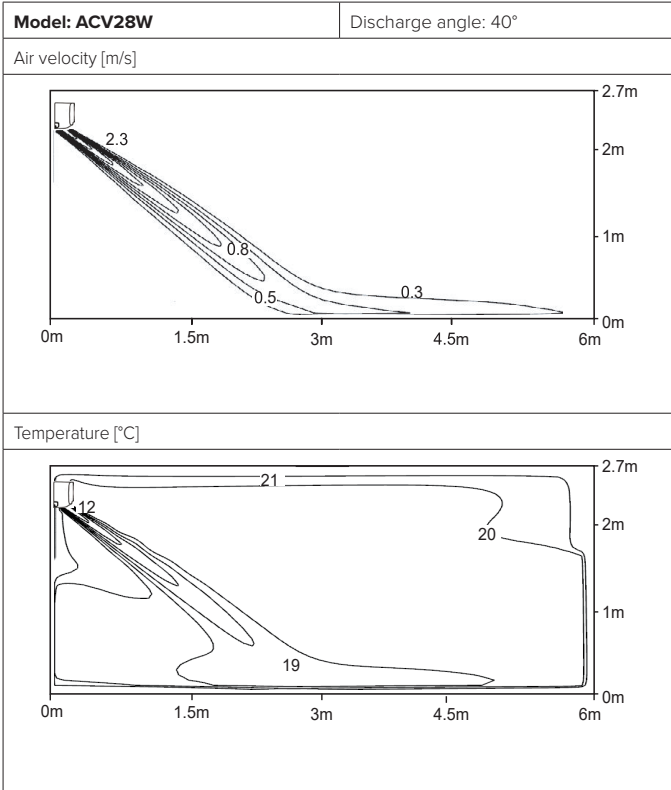

Heating

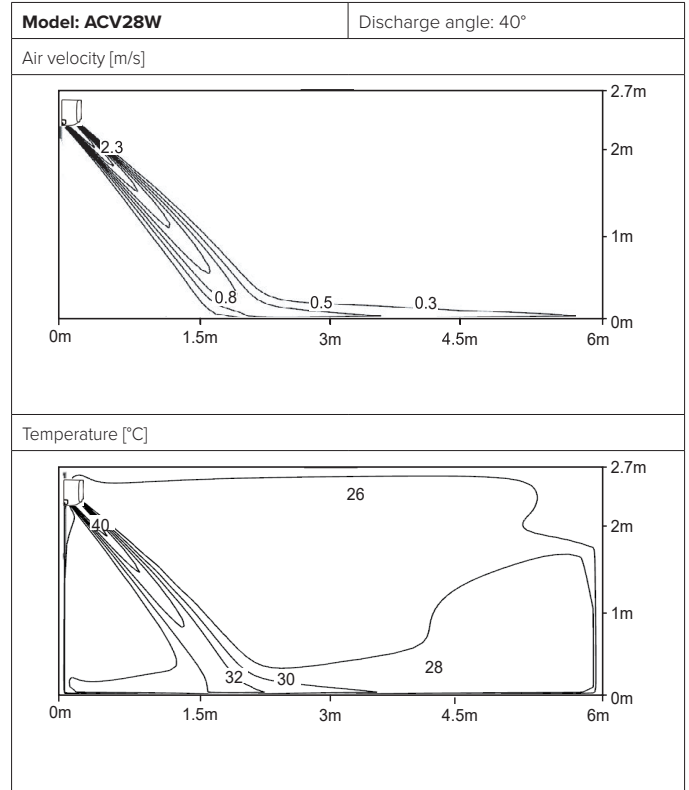

Cooling

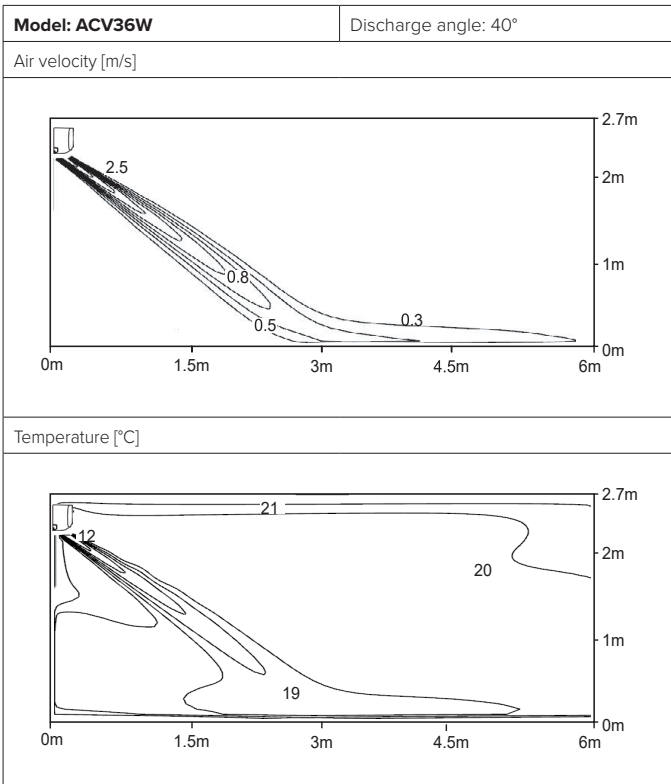

Heating

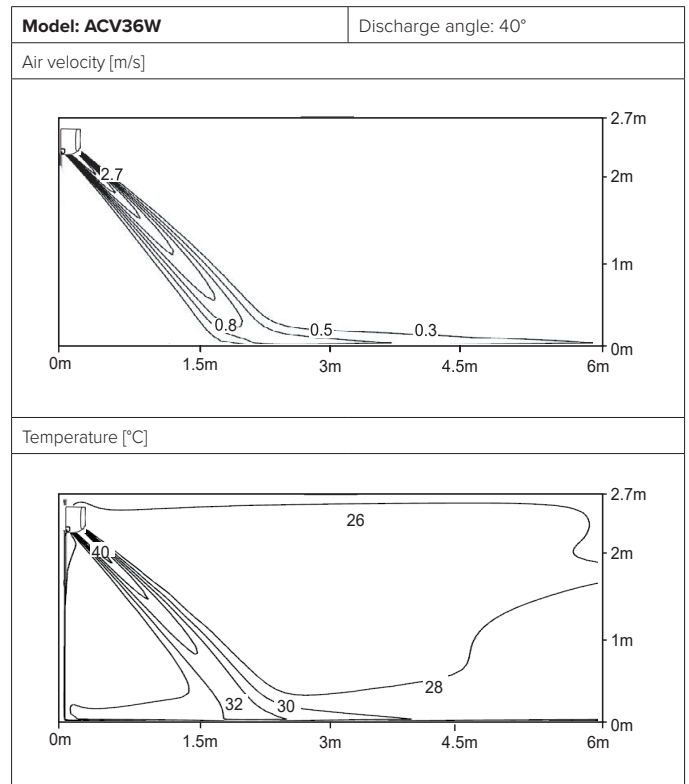

General data

Temperature data

Cooling

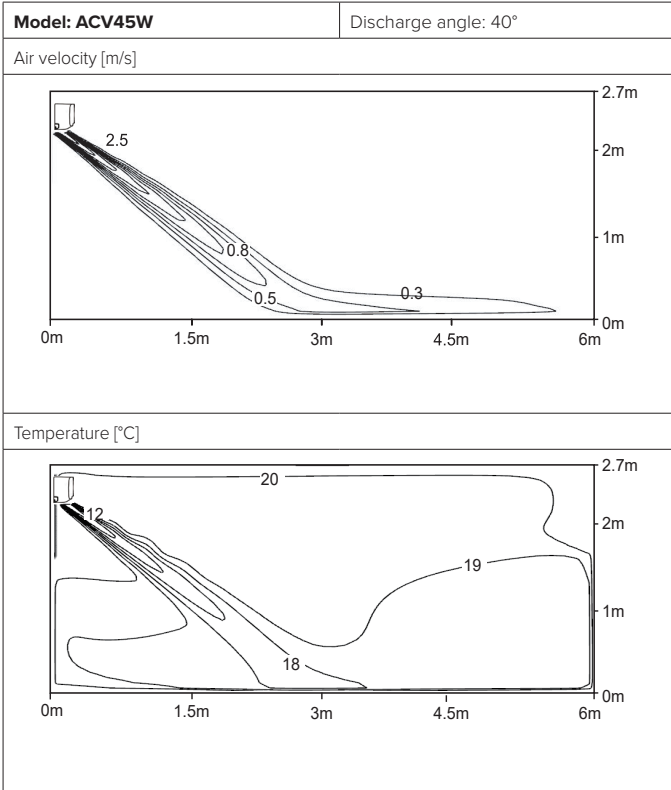

Heating

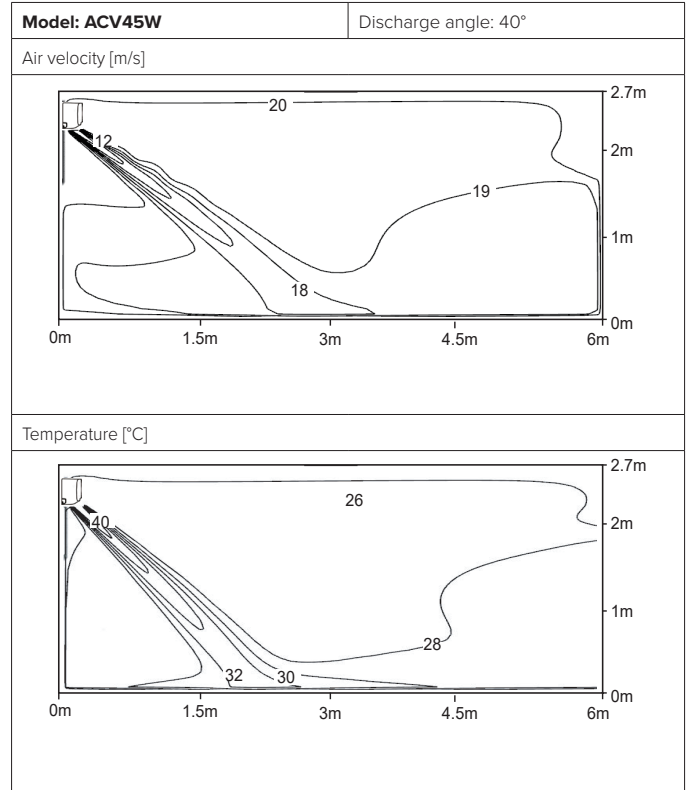

Cooling

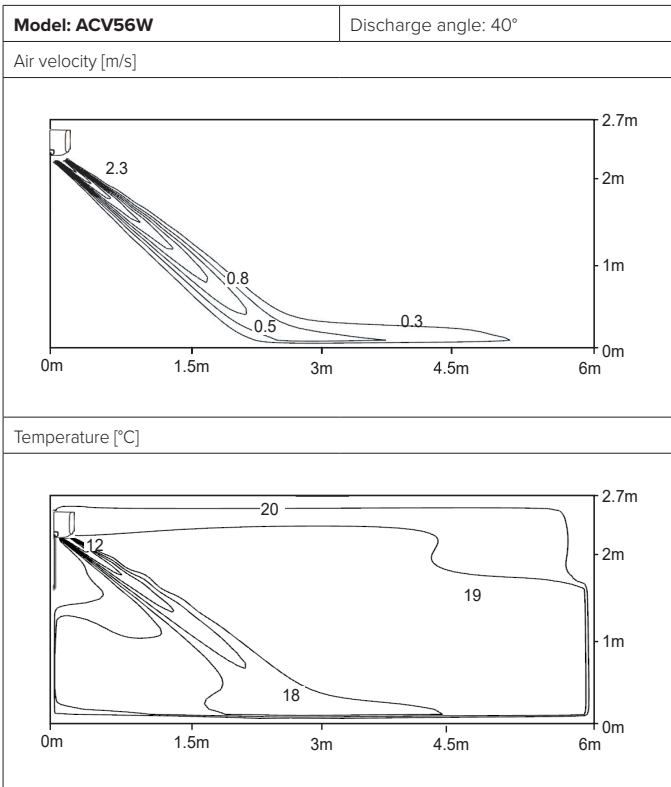

Heating

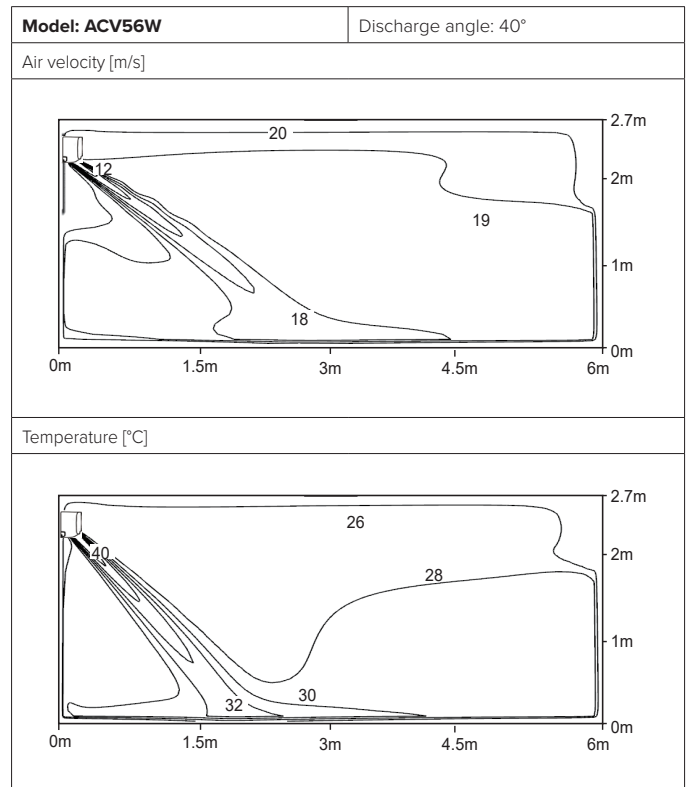

General data

Temperature data

Cooling

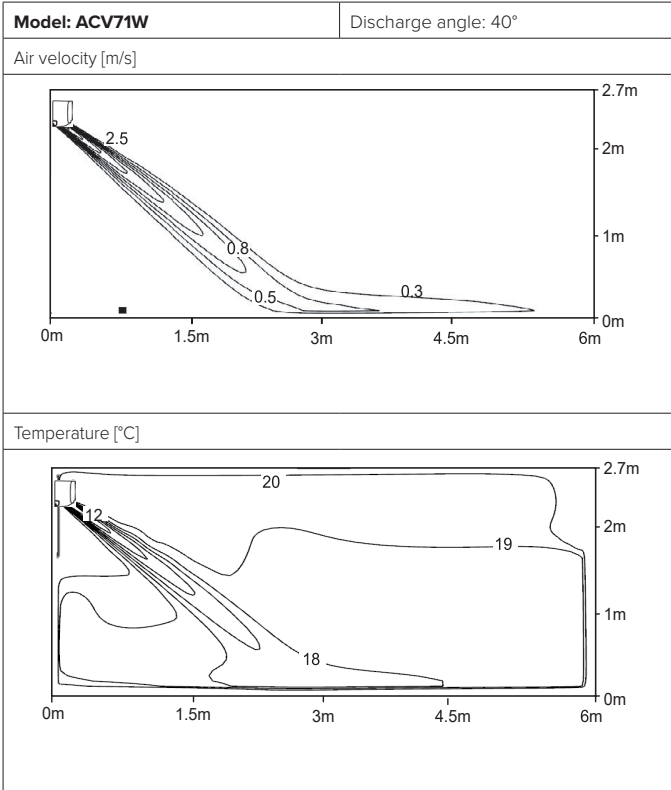

Heating

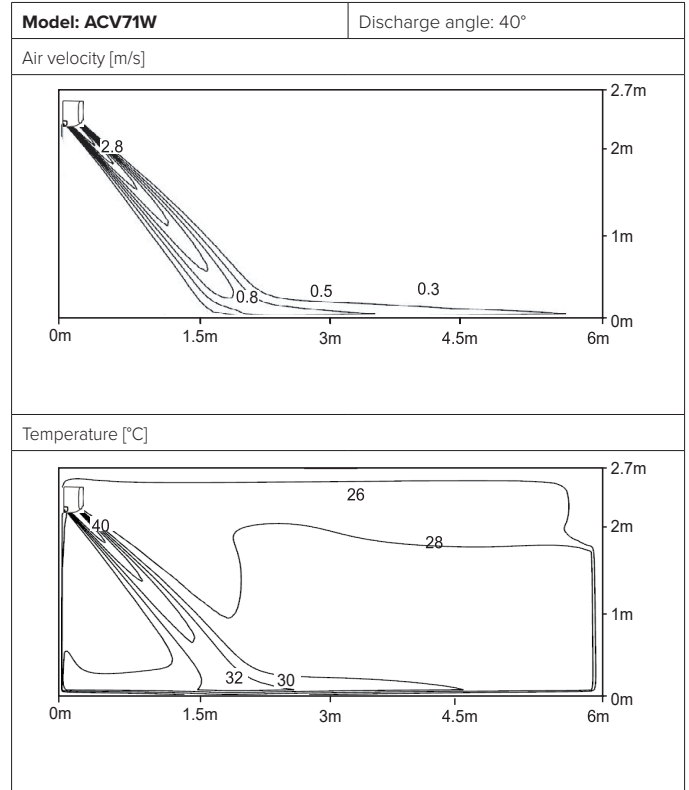

Cooling

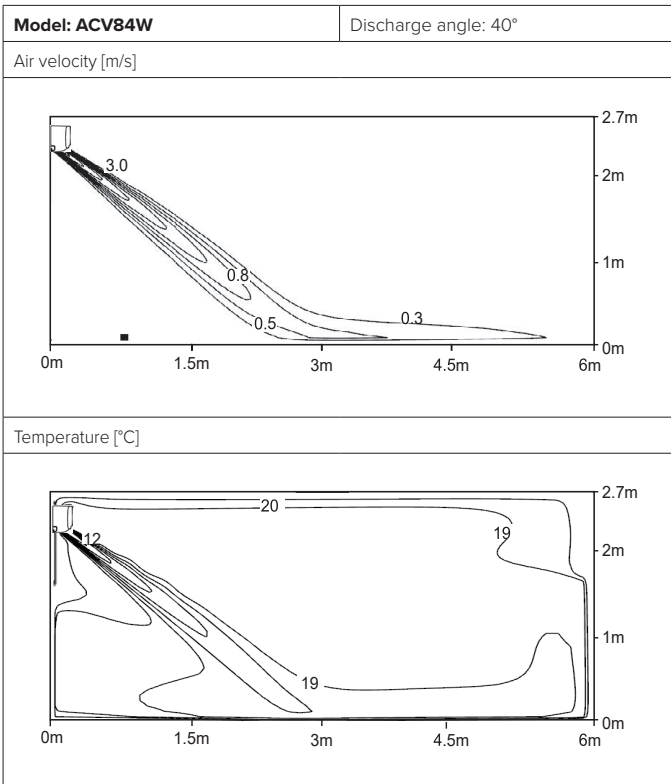

Heating

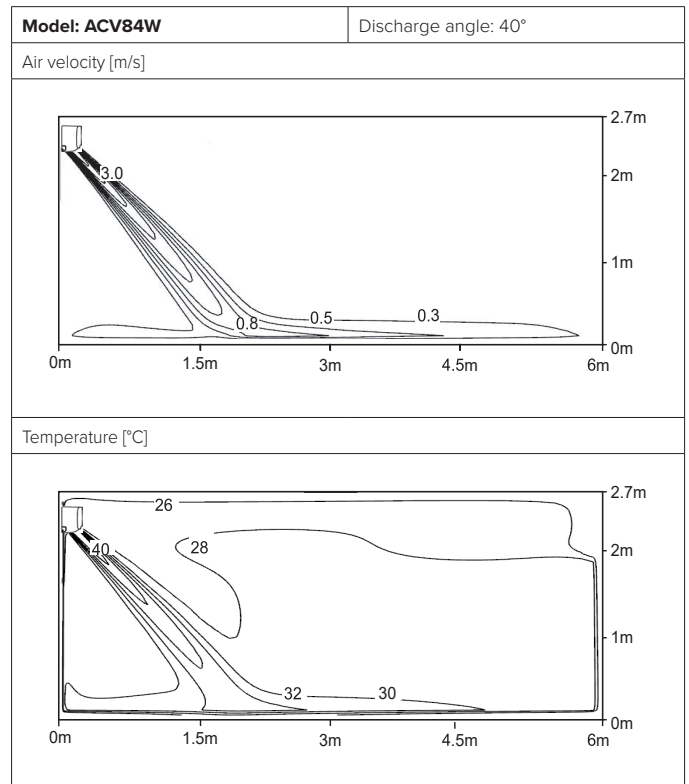

General data

Component data

Indoor heat exchanger and fan

Model			ACV28W	ACV36W	ACV45W	
Heat Exchanger	Heat Exchanger Type		—	Multi-Pass Cross Finned Tube		
	Tube	Material	—	Copper		
		Outer Diameter	mm	7.0	7.0	7.0
		Rows	—	2	2	2
	Fin	Material	—	Aluminum		
		Pitch	mm	1.4	1.4	1.4
	Maximum Operating Pressure		Mpa	4.15	4.15	4.15
	Total Face Area		m ²	0.17	0.17	0.24
Quantity		—	1	1	1	
Air Supply	Fan	Type	—	Cross-flow Fan		
		Quantity	—	1	1	1
		Outer Diameter	mm	92	92	107
		Revolution	rpm	1100/1050/1000/ 950/900/850	1150/1050/1000/ 950/900/850	1005/970/930/ 830/800/760
		Nominal Air Flow	m ³ /h	590/550/520/ 490/450/420	620/550/520/ 490/450/420	690/660/620/ 540/520/480
	Fan Motor	Type	—	Water-proof Case		
		Starting Method	—	DC Driven		
		Nominal Output	W	25	25	35
		Quantity	—	1	1	1
		Insulation Class	—	E	E	E

* Nominal output is the power on the nameplate of motor

Model			ACV56W	ACV74W	ACV84W	
Heat Exchanger	Heat Exchanger Type		—	Multi-Pass Cross Finned Tube		
	Tube	Material	—	Copper		
		Outer Diameter	mm	7.0	7.0	7.0
		Rows	—	2	2	2
	Fin	Material	—	Aluminum		
		Pitch	mm	1.4	1.4	1.4
	Maximum Operating Pressure		Mpa	4.15	4.15	4.15
	Total Face Area		m ²	0.32	0.32	0.32
Quantity		—	1	1	1	
Air Supply	Fan	Type	—	Cross-flow Fan		
		Quantity	—	1	1	1
		Outer Diameter	mm	107	107	107
		Revolution	rpm	1000/950/900/ 850/800/760	1200/1100/1050/ 950/850/780	1395/1300/1200/ 1050/900/800
		Nominal Air Flow	m ³ /h	970/900/850/ 800/730/690	1200/1080/1020/ 900/800/700	1400/1320/1200/ 1020/850/730
	Fan Motor	Type	—	Water-proof Case		
		Starting Method	—	DC Driven		
		Nominal Output	W	35	35	35
		Quantity	—	1	1	1
		Insulation Class	—	E	E	E

* Nominal output is the power on the nameplate of motor

General data

Refrigerant cycle

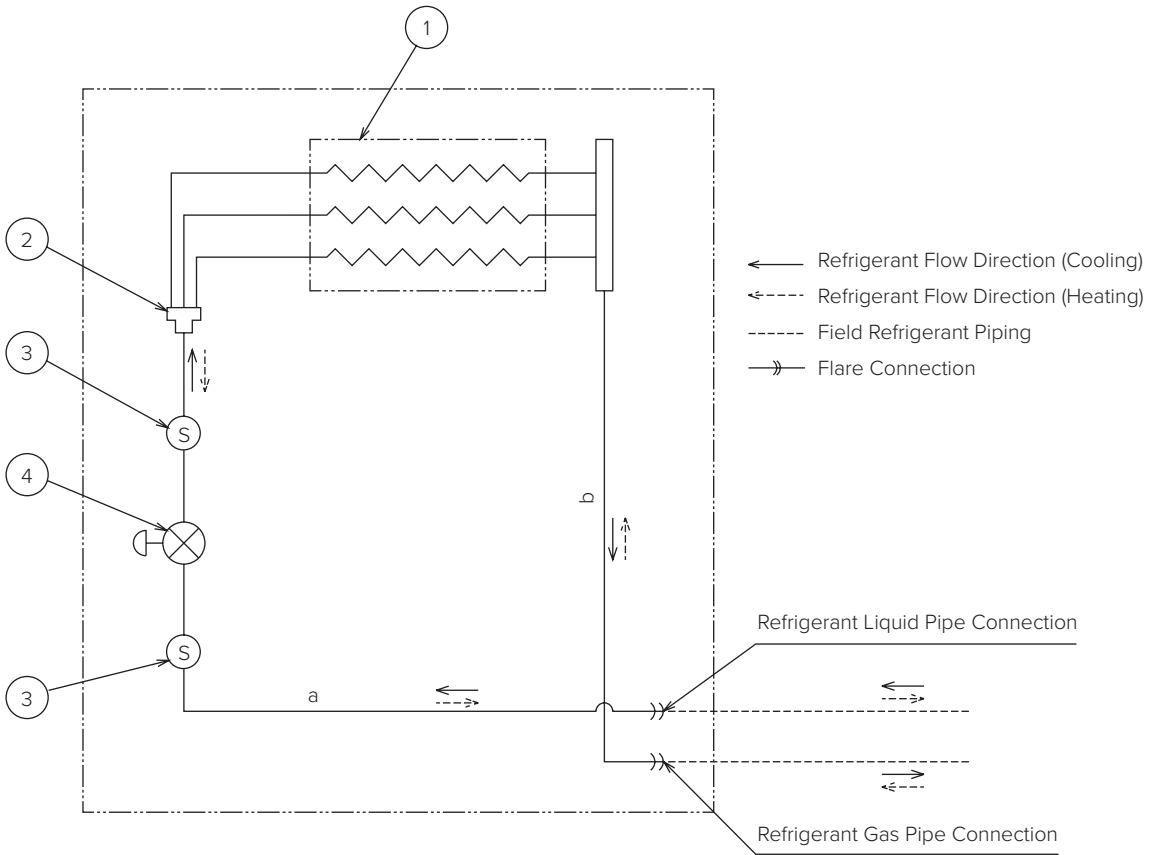

No. Reference	Part Name
1	Heat exchanger
2	Splitter
3	Strainer
4	Micro-Computer Control Expansion Valve

General data

Electrical data

Indoor unit

Model		Unit Main Power			Applicable Voltage		Indoor		
		VOL	PH	HZ	Maximum	Minimum	PH	RNC (Cooling/ Heating)	IPT (Cooling/ Heating)
Wall Mounted Type	ACV28W	220-240	1	50	264	198	1	0.29/0.29	0.02/0.02
	ACV36W							0.30/0.34	0.03/0.03
	ACV45W							0.30/0.36	0.02/0.03
	ACV56W							0.32/0.36	0.03/0.03
	ACV71W							0.46/0.60	0.05/0.07
	ACV84W							0.65/0.65	0.08/0.08

VOL: Rated Unit Power Supply Voltage

PH: Phase (Φ)

HZ: Frequency (Hz)

RNC: Running Current (A)

IPT: Input (kW)

Safety and Control Device Setting

Model		28~84	
For control circuit Fuse capacity		A	5
Freeze protection Thermostat	cut-out	°C	0
	cut-in	°C	14







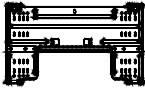

Indoor unit installation

Factory supplied accessories

Ensure the following accessories are included with the indoor unit.

NOTE

If any of these accessories are not packed with the unit please contact your supplier.

Accessory	Quantity	Purpose
Mounting bracket 	1	For mounting indoor unit
Wireless remote control switch 	1	To control the indoor unit
Screw 	6	For mounting bracket
Screw cover 	1 (28-36) 3 (45-84)	Cover screw hole
Thermal insulation pipe 	1	For refrigerant pipe
Plug 	6	For mounting bracket
Refrigerant pipe connection 	2	For refrigerant pipe
Adapter 	1 (28-36) 2 (56-84)	For Piping Connection

Indoor unit installation

Initial check

- Install the indoor unit with a proper clearance around it for operation and maintenance working space,

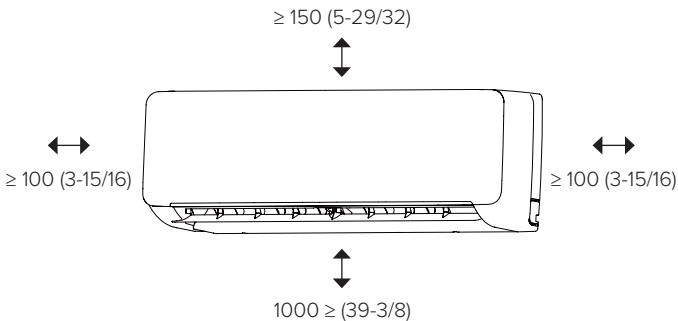

Operation and maintenance space. Unit: mm (in.)

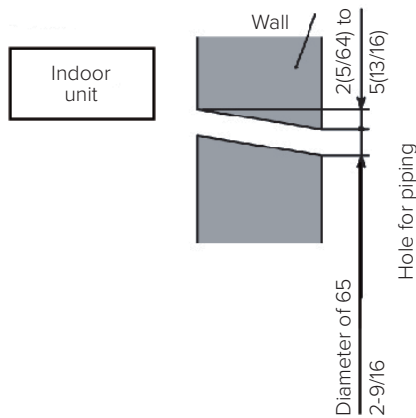

Hole for piping in the wall. Unit: mm (in.)

- Consider the air distribution from the indoor unit to the space of the room, and select a suitable location so that uniform air temperature in the room can be obtained.
- Avoid obstacles which may hamper the air intake or the air discharge flow.
- Do not install the indoor unit in a machine shop or kitchen where vapour from oil or its mist flows to the indoor unit. The oil will deposit on the heat exchanger, thereby reducing the indoor unit performance, and may deform and in the worst case, break the plastic parts of the indoor unit.
- Pay attention to the following points when the indoor unit is installed in a hospital or other facilities where there are electronic waves from medical equipment.
 - Do not install the indoor unit where the electromagnetic wave is directly radiated to the electrical box, remote control cable or remote control switch
 - Install the indoor unit and components as far as practical or at least 3m(9.8ft.) from the electromagnetic wave radiator.
 - Prepare a steel box and install the remote control switch in it. Prepare a steel conduit tube and wire the remote control cable in it. Then, connect the ground wire with the box and the tube.
 - Install a noise filter when the power supply emits harmful noises.
- To avoid any corrosive action to the heat exchangers, do not install the indoor unit in an acid or alkaline environment.

Installation of mounting bracket onto wall

The dimensions of the mounting bracket and the unit installation are indicated in figure below.

- Decide an installing location for the mounting bracket according to the indoor unit location and piping direction.
- Find the center of the mounting bracket according to the mark on it. Then install a screw to fix it preliminary.
- Keep the mounting bracket horizontally with a horizontal ruler or dropping line.
- Drill holes with depth of 32mm in the wall for fixing the bracket as show in figure below.
- Insert the plastic plugs to the hole, fix the mounting bracket with tapping screws.
- Align the 2 holes of the paper board with the 2 holes of the mounting bracket as show in figure below.
- Inspect if the mounting plate is well fixed. Then drill a hole for piping.

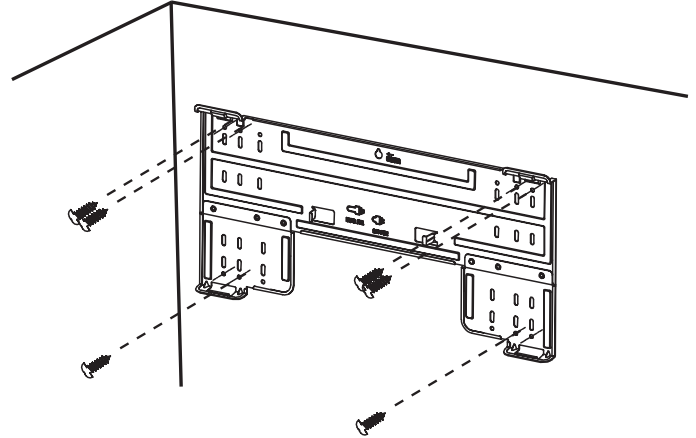

Mounting on concrete or concrete block wall

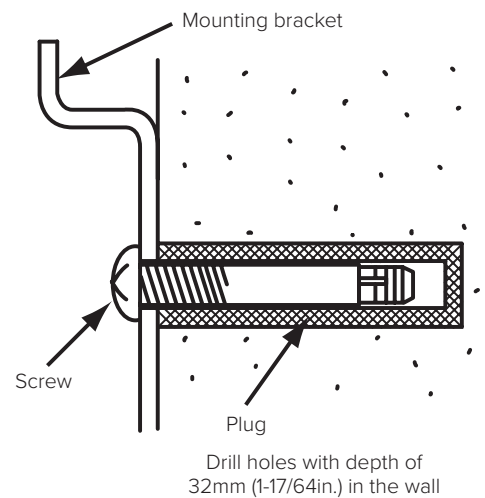

NOTE

The mounting bracket should be installed so that the side of drain piping connected is slightly (about 3mm) lower than the other side, in order to avoid the incorrect position of the drainage. (Drain piping connection can be performed from both right side and left sides of the unit.)

Indoor unit installation

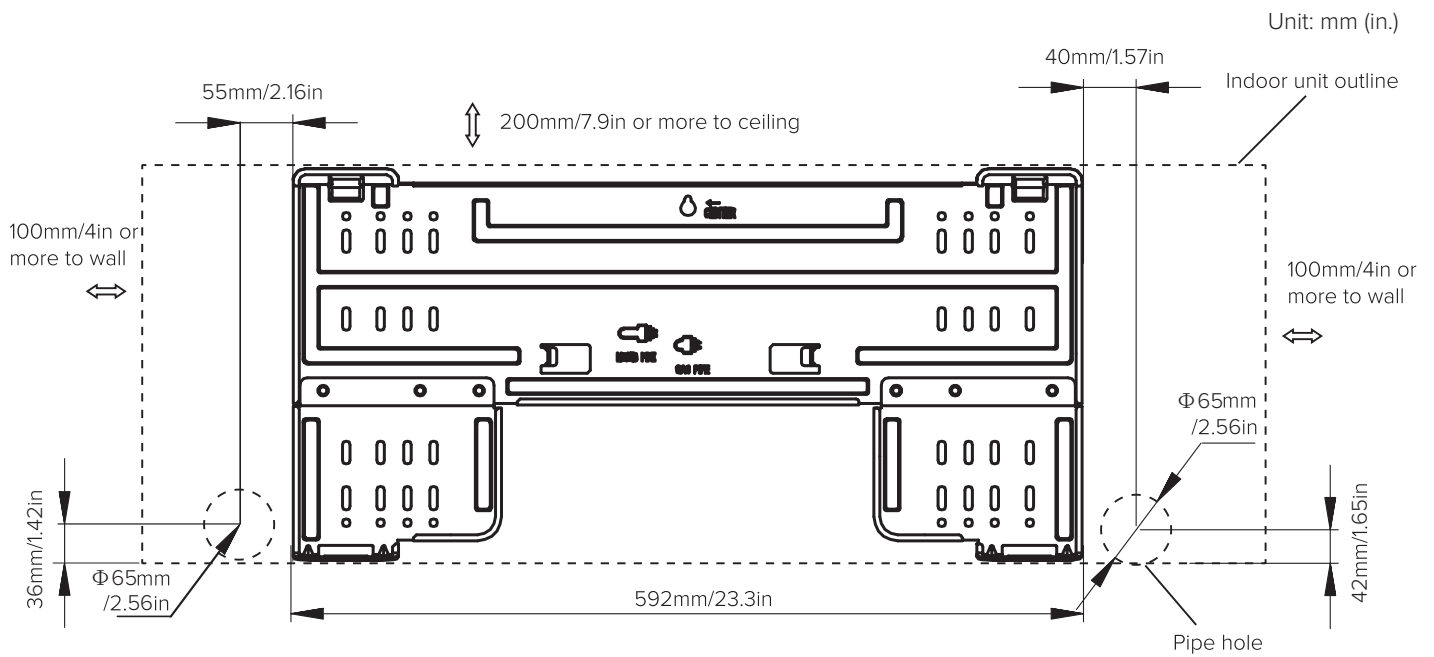

ACV28~36W Mounting bracket

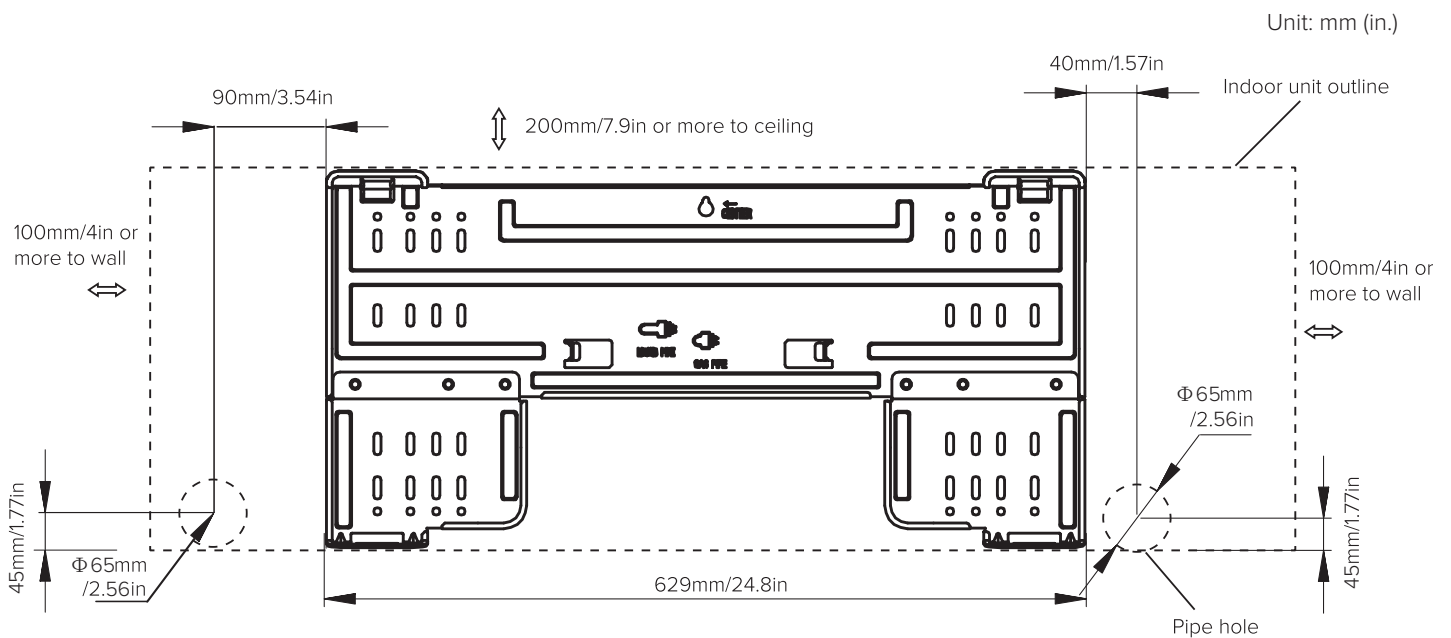

ACV45W Mounting bracket

Indoor unit installation

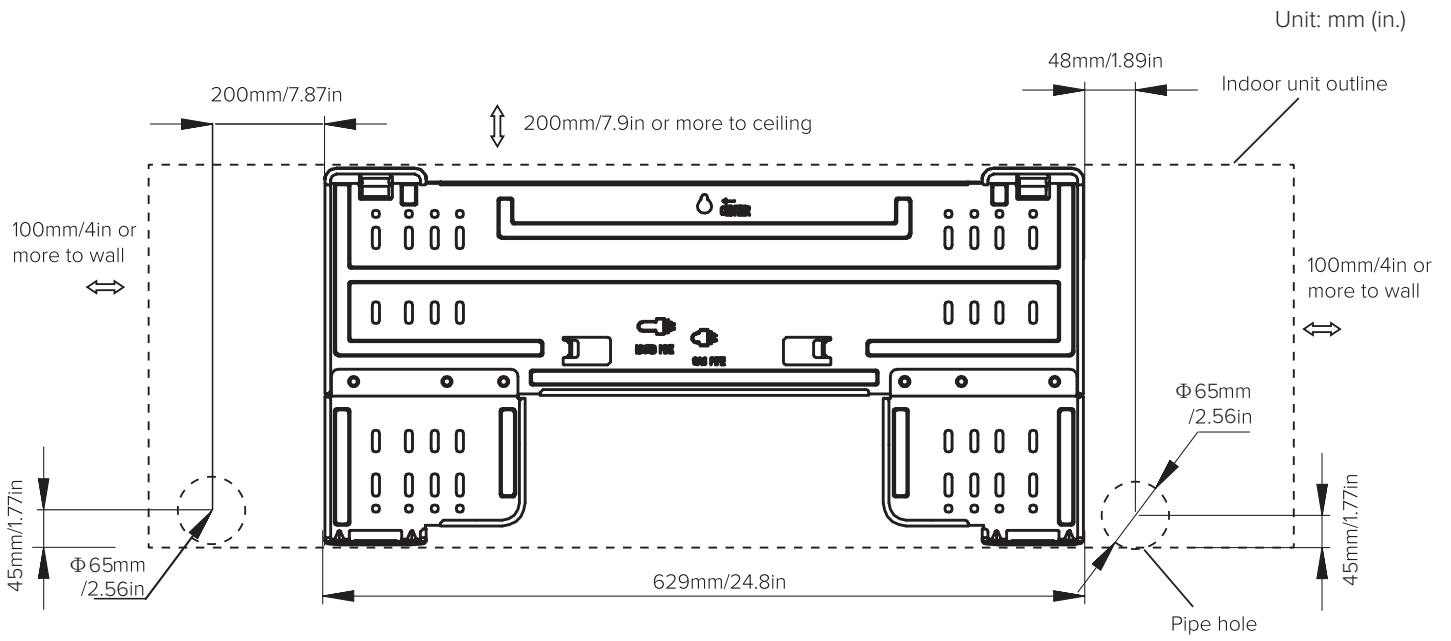

ACV56~84W Mounting bracket

Indoor unit installation

Mounting the indoor units

1. Hang the unit onto mounting bracket (Fig. A).
2. Open the screw cover as shown in Fig. B and remove the screw. Then remove the trim panel as shown in Fig. C.
3. Open the two supports on the wall mounting bracket to 90 degrees as shown in Fig. D and move the unit step by step to reach the best location (Fig. E)

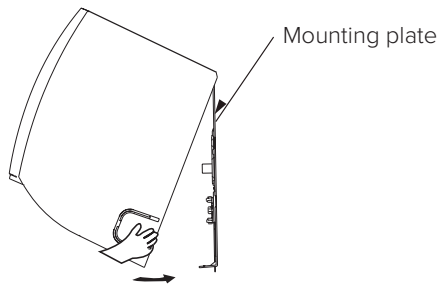

Fig. A

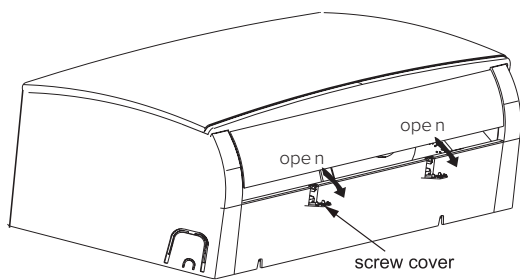

Fig. B

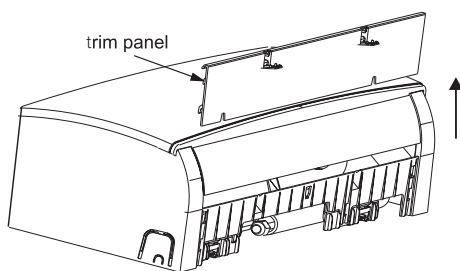

Fig. C

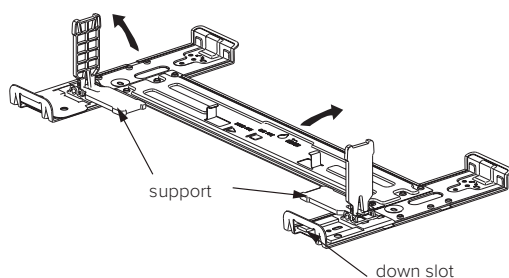
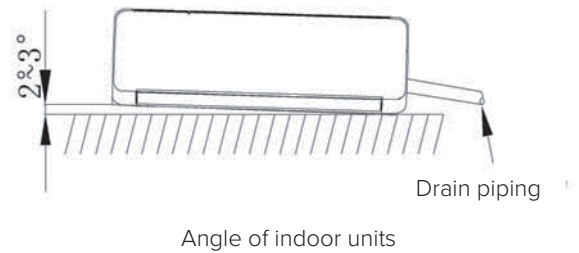

Fig. D

⚠ CAUTION

Ensure the unit is securely attached to the bracket. If not, it may drop from the bracket, resulting in a serious accident.

1. The side of the drain pipe is downward-sloping 2 degrees or 3 degrees in the process of the unit installation.
2. Check the drainage of the drain pan through water overflow test.



Indoor unit installation

Removing the flat panel

To connect the refrigerant piping and wiring, or to check the drain water flow, the flat panel must be removed. Follow the instructions below carefully, taking care not to scratch any resin components.

1. Hold both sides of the flat panel and open it, gently pull the right arm toward the inner side. Slightly close the flat panel and pull it, then remove the flat panel.

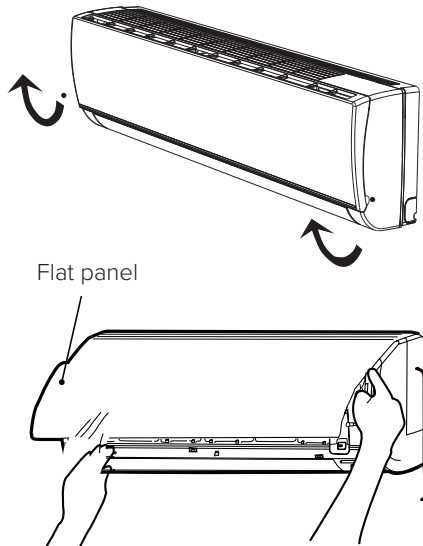

2. Pay attention to the junction of grille from each side, to prevent breaking off.

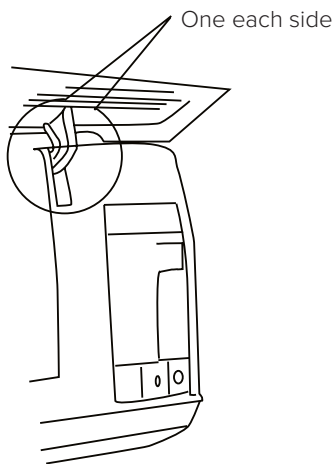

⚠ CAUTION

Do not apply excessive force - such as hitting - when removing the flat panel. Doing so may damage the unit body.

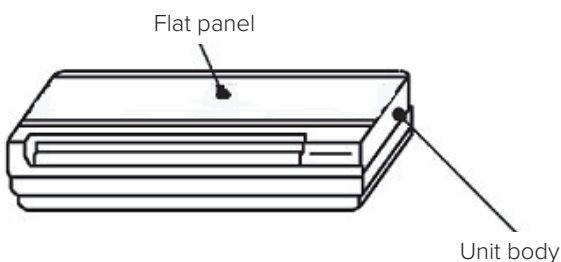

Install the flat panel

1. Press flat panel down, make the two joints of the flat panel tightly fasten.

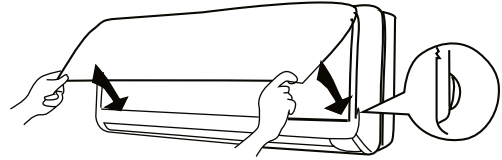

2. There are four stoppers inside of the flat panel. Check to ensure that there is no gap between flat panel and unit body.

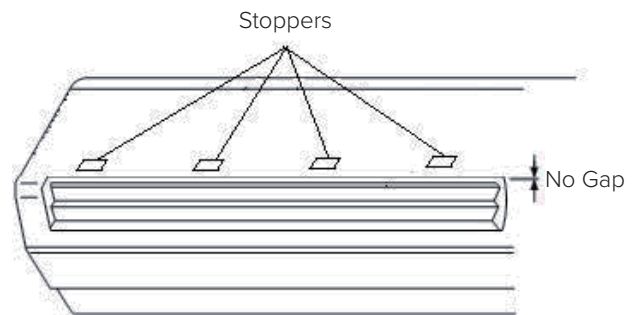

3. Put screws cover into the screw hole in the air outlet.

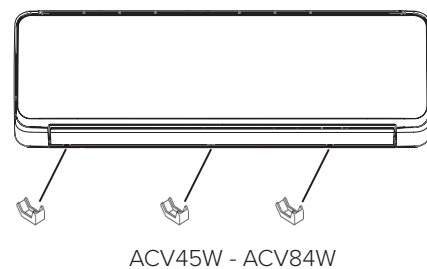
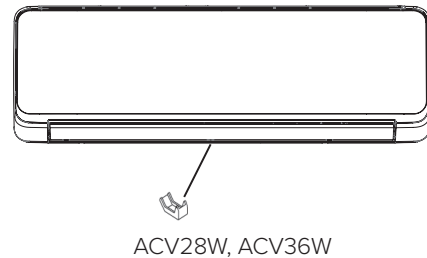

⚠ CAUTION

Any gap will lead to leak or frost.

Refrigerant piping work

⚠ DANGER

Only use R410A refrigerant in the refrigerant cycle. Do not use oxygen, acetylene, or any other flammable or toxic gases when performing a leakage or air-tightness test. These gases are extremely dangerous and may cause an explosion.

For testing purposes, it is recommended to use compressed air, nitrogen, or refrigerant.

Piping materials

1. Prepare locally-supplied copper pipes.
2. Select the piping size from the following table.

Model	Gas pipe	Liquid pipe
28~36	φ9.53(3/8)	φ6.35(1/4)
45	φ12.7(1/2)	φ6.35(1/4)
56~84	φ15.88(5/8)	φ9.53(3/8)

3. Select clean copper pipes, ensuring they are free from dust and moisture. Before connecting, blow nitrogen or dry air through the pipes to remove any dust or foreign materials.

Piping connection

1. Position of piping connection as shown.
2. The indoor unit allows for piping connections in three directions: to the rear, right side, or left side of the unit. This flexibility enables you to choose the most suitable piping direction for the room layout.

Right side piping

Take off the small cover from right side.

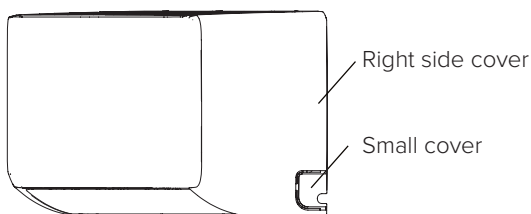

Left side piping

Take off the small cover from right side.

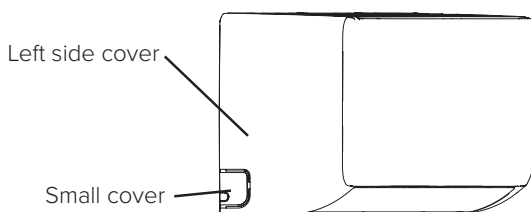

- Rear side piping
Bend the pipe directly toward the rear.

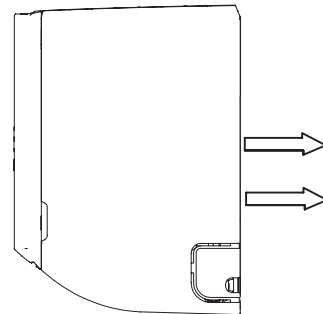

⚠ CAUTION

- Cap the end of the pipe when the pipe is to be inserted through a hole.
- Do not put pipes on the ground directly without a cap or vinyl tape at the end of the pipe.

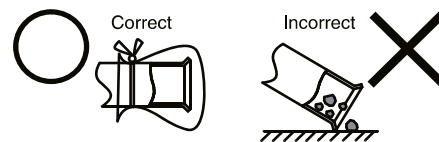

- When bending the pipes, firmly fix the pipe at the heat exchanger side.

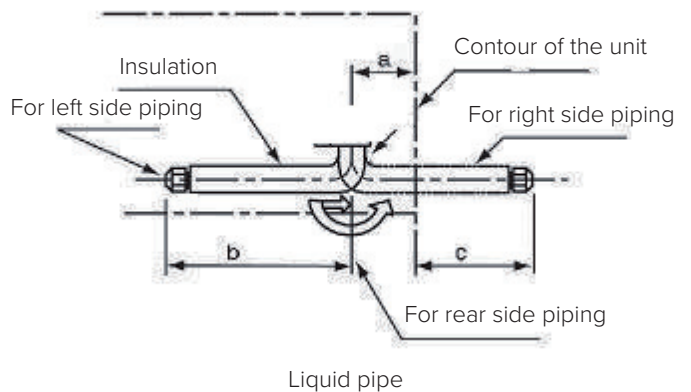

Unit: mm (in.)

Model	a	b	c	d
28~36	86 (3-25/64)	456 (3-25/64)	370 (14-9/16)	456 (3-25/64)
45	64 (2-33/64)	437 (17-13/64)	373 (14-11/16)	(3-25/64)
56~84	60 (2-23/64)	464 (18-17/64)	404 (15-29/32)	456 (3-25/64)

Refrigerant piping work

- Bend the gas pipe at the flexible pipe part.

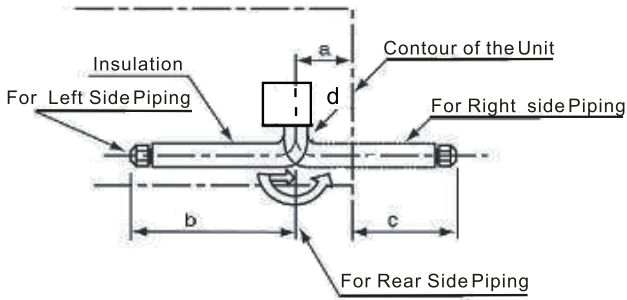

Unit: mm (in.)

Model	a	b	c	d
28~36	101 (3-31/32)	390 (15-23/64)	289 (11-3/8)	15R (19/32R)
45	78 (3-5/64)	396 (15-19/32)	318 (12-33/64)	20R (25/32R)
56~84	76 (3)	431 (16-31/32)	355 (13-31/32)	25R (63/64R)

Tightening Work of Flare Nut

- When tightening the flare nut, use two spanners as shown.

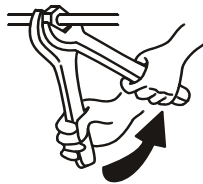

Pipe Diameter	Torque (N·m)
φ6.35	20
φ9.53	40
φ12.7	60
φ15.88	80

- Insulate the refrigerant pipes as shown.

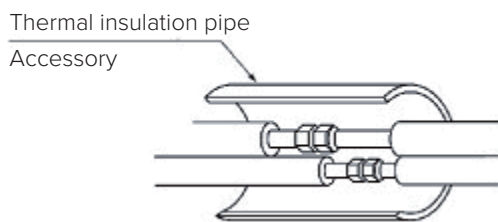

Insulation on pipes

- Evacuation and refrigerant charging procedures should be performed according to "Outdoor Unit User Manual".

⚠ CAUTION

An excess or a shortage of refrigerant is the main cause of trouble to the units. Charge the correct refrigerant quantity.

- Put screws cover into the screw hole in the air outlet.

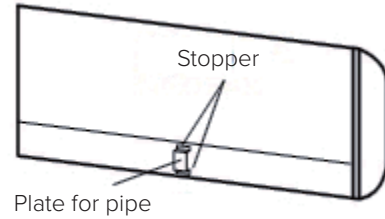

Drain piping

1. The standard direction of drain piping connection is right side as viewed from the discharge grilles. However, it can be performed from the left side or rear side.

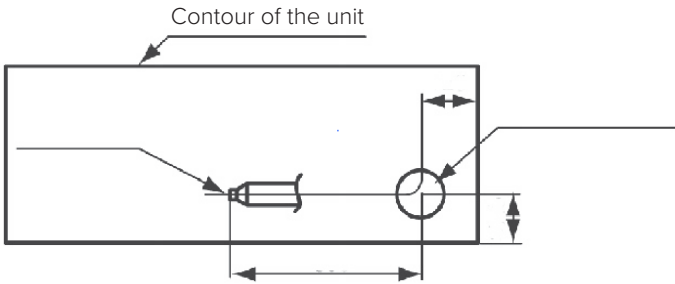

Unit: mm (in.)

Model	a	b
28~36	140 (5-33/64)	590 (23-15/64)
45	168 (6-39/64)	600 (23-5/8)
56~84	195 (7-43/64)	600 (23-5/8)

Direction of drain piping

2. When the left-side drain pipe connection is performed, remove the drain plug of left-side, and then attach this plug to the right-side in order to change drain piping connection from right-side to left-side.

(A) Draw out the drain plug and drain pipe.

Remove the fixing screw for right-side drain pipe and draw out the drain pipe from drain boss.

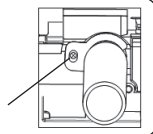

Use pliers to pull out the drain plug for left-side. (This is an easier way to remove the drain cap).



(B) Insert the drain plug and drain pipe

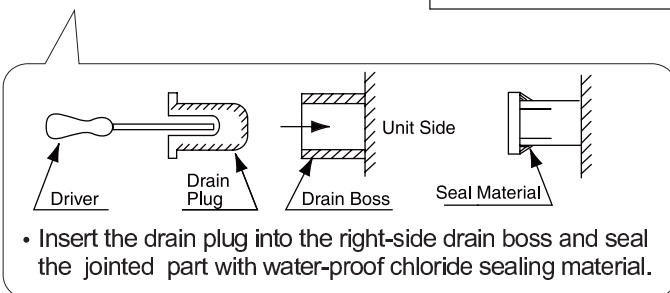
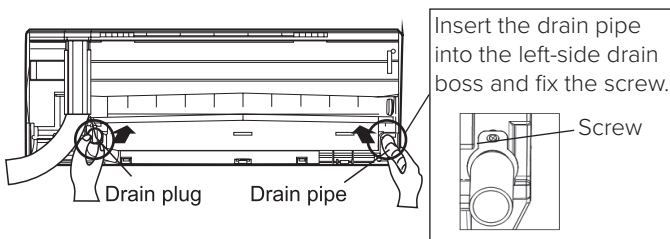

⚠ CAUTION

Insufficient insertion may result in water leakage.

3. Provide a vinyl chloride pipe, VP20.
4. Connect a drain piping as shown. Use adhesive tape for connecting the drain pipe.

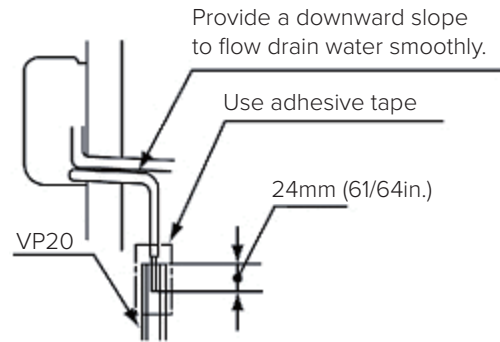

5. Pour water into the drain pan to confirm proper drainage.

⚠ CAUTION

- Do not connect the drain pipes with sanitary or sewage or any other drainage pipe.
- When installing the pipe, do not tie the drain pipe and refrigerant pipe together.
- Pay attention to the thickness of the insulation when the left side piping is performed. If it is too thick, piping can not be installed in the unit.

⚠ CAUTION

- Do not create an upper-slope or rise for the drain piping, since drain water can flow back to the unit and leakage to the room will occur when the unit operation is stopped.
- Do not connect the drain pipe with sanitary or sewage piping or any other drainage piping.
- When the common drain piping is connected with other indoor units, the connected position of each indoor unit must be higher than the common piping. The pipe size of the common drain pipe must be large enough according to the unit size and number of units.

Electrical wiring

⚠ WARNING

- Turn OFF the main power switches to the indoor unit and outdoor unit before electrical wiring or periodical check, and wait for at least 10 minutes.
- Check to ensure the indoor and outdoor fans have stopped before electrical wiring or periodical check.
- Protect the wires, drain pipes, electrical parts, etc. from rats or other small animals. If not protected, rats may gnaw at unprotected parts, which may lead to a fire.
- Avoid the contact of wires with the refrigerant piping, sheet metal edges and electrical components in unit. Otherwise, the wires may get damaged or even cause a fire.
- Use ELB (earth leakage breaker) with medium sensing rate (ELB with action time being equal to 0.1 seconds or less). Failing to do so may result in electric shock or a fire.
- The wires must be firmly secured. External force applied to terminals may cause a fire.
- It is forbidden to connect a plurality of power lines into one power terminal block. At the indoor unit side of air conditioner, power wiring can be extended through a power distribution box. Be sure to calculate the wiring capacity carefully, since excessively low wiring capacity may frequently cause fire.
- Ensure all points have been checked thoroughly.

⚠ CAUTION

- Tighten screws according to the following torque.

N·m(ft·lbs)

M3.5: 1.2(0.89)
M4: 1.0~1.3(0.7~1.0)
M5: 2.0~2.4(1.5~1.8)
M6: 4.0~5.0(3.0~3.7)
M8: 9.0~11.0(6.6~8.1)
M10: 18.0~23.0(13.3~17.0)

- Wrap the accessory packing around the wires, and plug the wiring connection hole with the seal material to protect the product from any condensate water or insects.
- Tightly secure the wires with the cord clamp inside the indoor unit.
- Secure the cable of the remote control switch using the cord clamp inside the electrical box.

General check

1. Make sure that the field-supplied electrical components (main power switches, circuit breakers, wires, conduit connectors and wire terminals) have been properly selected according to the electrical data given in "Technical Catalog I". Make sure that the components comply with National Electrical Code (NEC).
2. Use shielded twist pair cable for transmission wiring between outdoor unit and indoor unit, remote controller wiring between indoor units and remote control switch.
3. Check to ensure that the power supply voltage is within $\pm 10\%$ of the rated voltage.
4. Check the capacity of the electrical wires. If the power source capacity is too low, the system cannot be started due to the voltage drop.
5. Check to ensure that the earth wire is connected.
6. Power Source Main Switch.
Install a multi-pole main switch with a space of 3.5mm(9/64in.) or more between each phase.

Electrical wiring connection

The electrical wiring connection for the indoor unit as shown

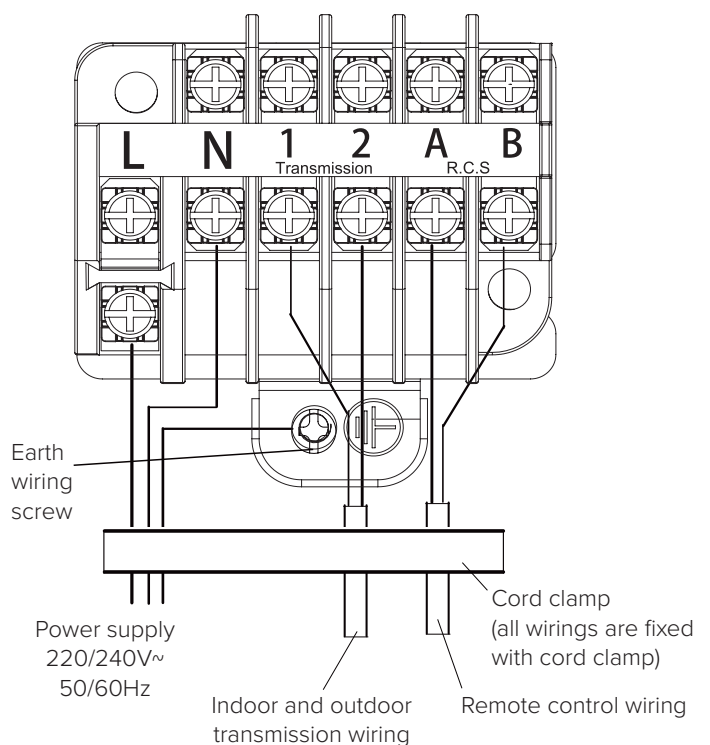

Electrical wiring diagram

⚠ WARNING

Before inspecting the electrical parts set the Operation Switch to OFF, and cut OFF the power supply!

NOTE

All the field wiring and equipment must comply with local codes.

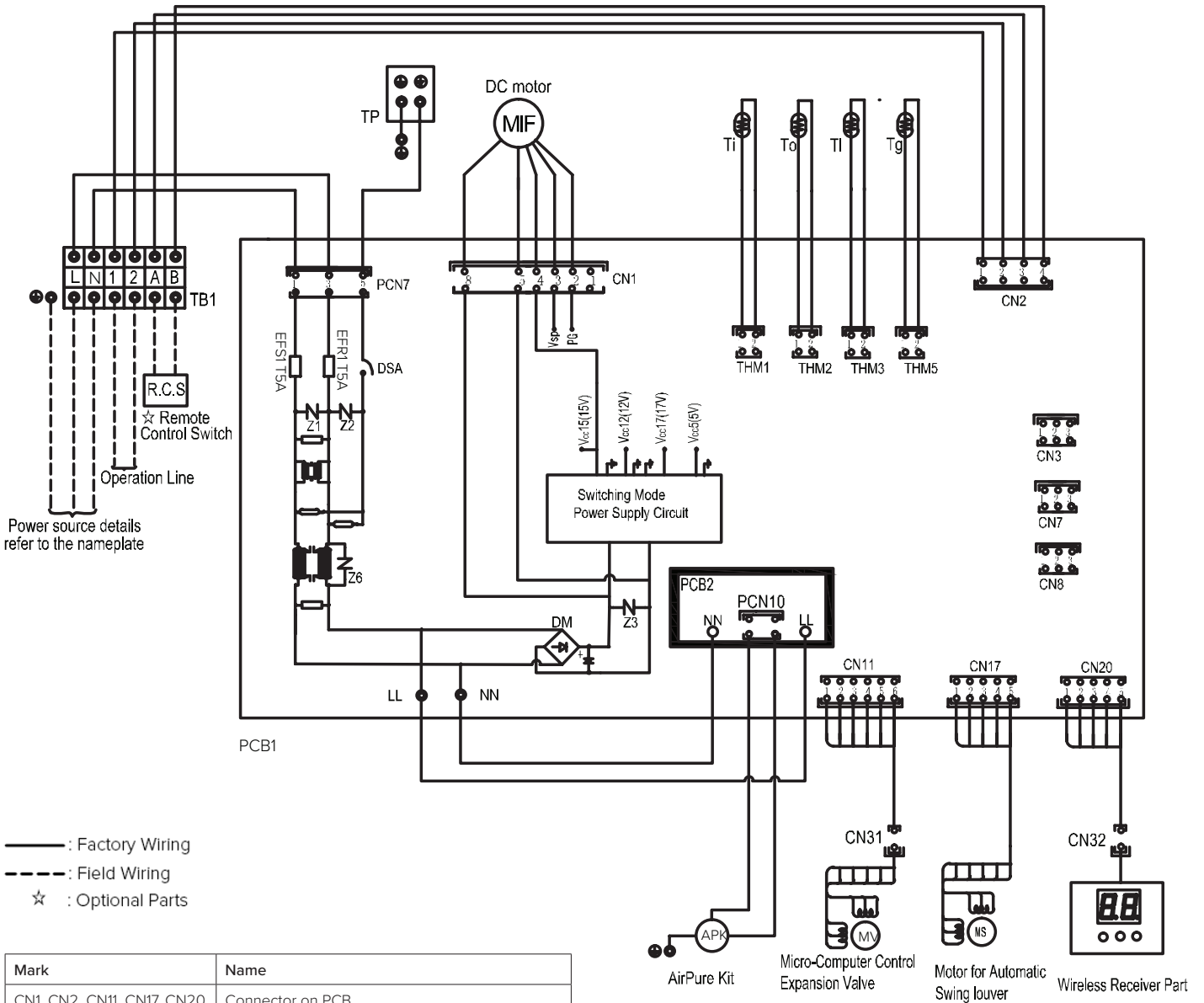

- : Factory Wiring
- - - : Field Wiring
- ☆ : Optional Parts

Mark	Name
CN1, CN2, CN11, CN17, CN20	Connector on PCB
CN31, CN32	Connector
EFR1, EFS1	Fuse
MS	Motor for Automatic Swing louver
MV	Micro-Computer Control Expansion Valve
MIF	Motor for Indoor Fan
PCN7	Connector on PCB
PCB1, PCB2	Printed Circuit Board
TB1	Terminal Board
TP	Terminal Plate for GND
THM ₁₋₃ , THM ₅	Thermistor
Z ₁₋₃ , Z ₆	Surge Absorber
APK	AirPure Kit
⊙	Terminals

Electrical wiring

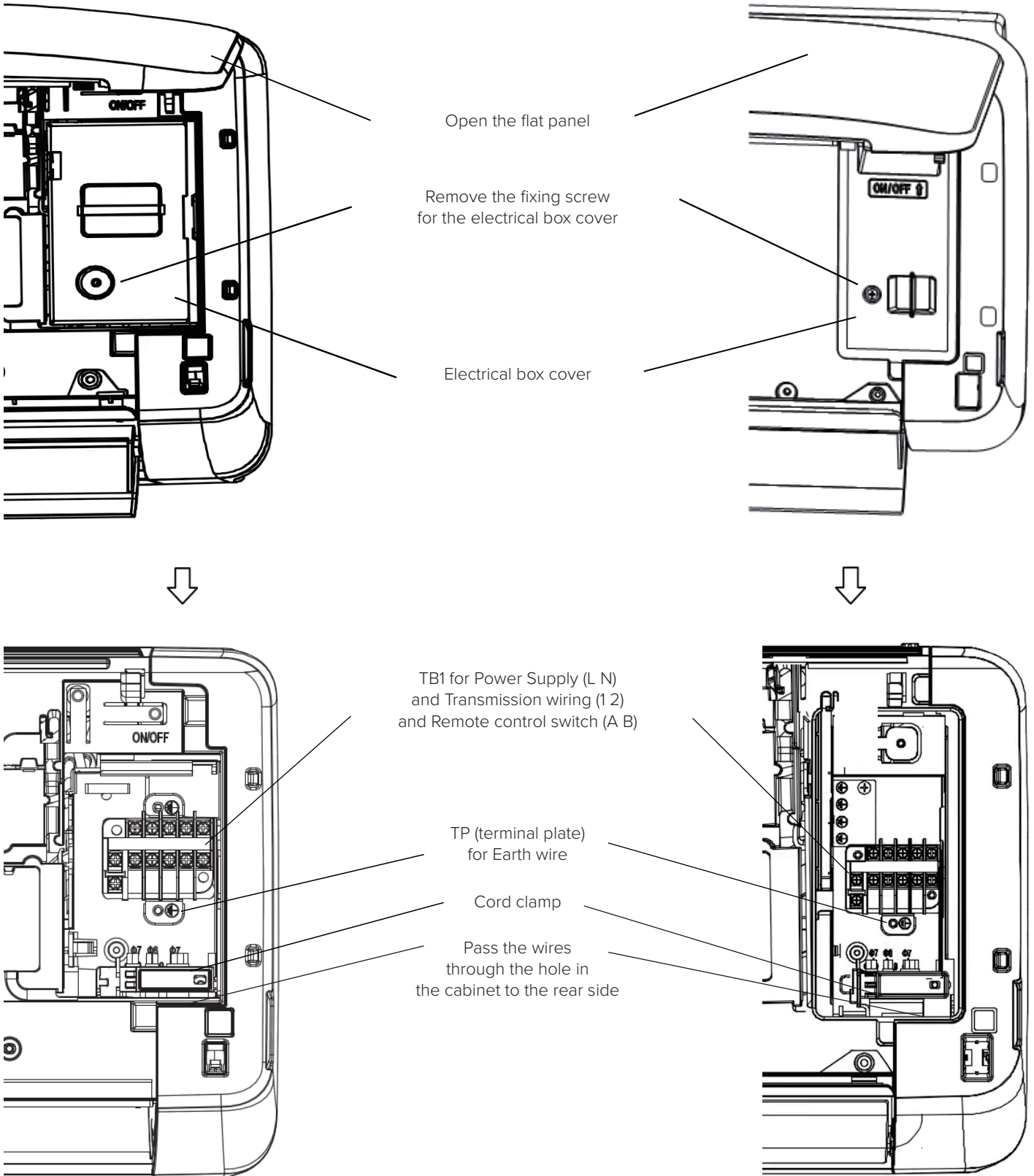

Electrical wiring

⚠ CAUTION

- ELB must be connected to the power circuit. If not, it may pose a danger.
- Apply the specified screw for terminal board and fasten the screw firmly.

NOTE

Wired Remote Control Switch and Wireless Remote Control Switch can not be used simultaneously. If Wired Remote Control Switch is connected, disconnect the wire of signal receptor in the electrical box as shown.

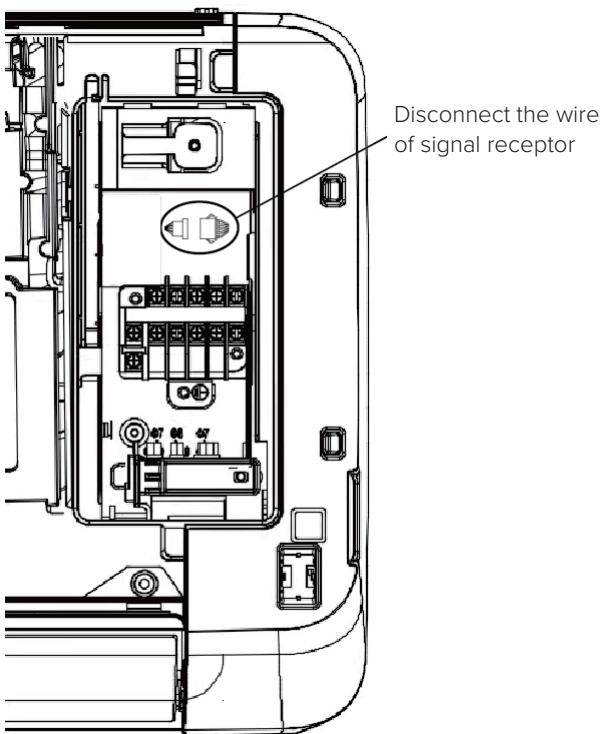

Connection description for signal receptor

Test run

Test run should be performed according to "Outdoor Unit User Manual".

⚠ WARNING

- Do not operate the system until all the check points have been cleared.
- (A) Check to ensure that the electrical resistance is more than 1 megohm, by measuring the resistance between ground and the terminal of the electrical parts. If not, do not operate the system until the electrical leakage is found and repaired.
- (B) Check to ensure that the stop valves of the outdoor unit are fully opened, and then start the system.
- (C) Check to ensure that the switch on the main power source has been ON for more than 12 hours, to warm the compressor oil by the crankcase heater.
 - Pay attention to the following items while the system is running.

(A) Do not touch any of the parts by hand at the discharge gas side, since the compressor chamber and the pipes at the discharge side are heated higher than 90°C.

(B) DO NOT PUSH THE BUTTON OF THE MAGNETIC SWITCH(ES). It will cause a serious accident.

Field setting

Field minimum wire sizes for power source

⚠ WARNING

- Use an ELB (Electric Leakage Breaker). If not used, it will cause an electric shock or a fire.



Model	Power source	Rated current	Power source cable size *1	Transmitting cable size *1
28	220~240V 50/60Hz	0.36A	1.5mm ²	0.75mm ²
36		0.43A		
45		0.45A		
56		0.45A		
71		0.75A		
84		0.81A		
Total current (A)			Wire (mm ²)	*1 DO NOT connect wires in series when the current exceeds 63A
1≤6			2.5	
6<1≤10			2.5	
10<1≤16			2.5	
16<1≤25			4	
25<1≤32			6	
32<1≤40			10	
40<1≤63			16	
63<1			*1	

NOTE



- Field wiring shall be in conformity to local laws and regulations, and all wiring operations must be performed by qualified professionals.
- Refer to relevant standards for above-noted power cord size.
- Where power cord is connected through junction box, be sure to determine the total current and choose wires based on the table below.
- As a minimum, the chosen power cord shall be compliant with requirements on neoprene sheathed wire #57 as stated in IEC 60245-1, while the power cord shall be made from copper conductor.
- The wiring specifications for weak-current communication circuit shall not be lower than that for RW(S)P shielded wires or equivalent, and the shielding layer shall be grounded.
- A switch that can ensure all-pole disconnection shall be installed between power supply and air conditioning unit in such a manner that the contact spacing shall not be less than 3mm.
- Once the power cord is damaged, the dealer or the professionals from designated maintenance department must be contacted in a timely manner for repair and replacement.
- For the installation of power cord, the ground wire must be longer than the current-carrying conductor.

Setting of dip switches

- DIP switch must be set with power sources of the indoor and outdoor units in OFF state. Otherwise, the settings are invalid.
- The dip switches are located on the PCB. Please set according to the following instructions.
 - Address of indoor units (DSW6): All indoor units must be numbered in sequence based on the diagram below. Outdoor units must be numbered from "0".

	DSW6 (Setting 0~63)	Ex.) Set address No. 16
Setting method	 Note: 8421 coding method	 No.5 is ON

- Refrigeration system cycle No. (DSW5) is required to be set. All are set to OFF before shipment.

	DSW5 (Setting 0~63)	Ex.) Set address No. 16
Setting method 2	 Note: 8421 coding method	 No.5 is ON

- Fuse Recover (DSW7)

No setting is required.

Setting position before shipment is at OFF.

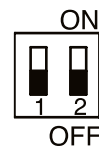

Once strong current is accidentally connected to Terminals 1 and 2 of TB, the PCB fuse will be blown. In such a case, it's essential to correct the wiring and then to set switch No. 1 to ON position.

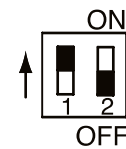

NOTE

- The "■" mark indicates position of dip switches. Figures show setting before shipment.

Field setting

⚠ CAUTION

Before setting dip switches, firstly turn OFF power source and set the position of the dip switches. If the switches are set without turning OFF the power source, the switches can not function.

To facilitate the DIP switch setting, the following table lists the decimal No. and its corresponding 8421 code.

Note: ● means ON; ○ means OFF

Decimal No	8421 code					
	1	2	3	4	5	6
0	○	○	○	○	○	○
1	●	○	○	○	○	○
2	○	●	○	○	○	○
3	●	●	○	○	○	○
4	○	○	●	○	○	○
5	●	○	●	○	○	○
6	○	●	●	○	○	○
7	●	●	●	○	○	○
8	○	○	○	●	○	○
9	●	○	○	●	○	○
10	○	●	○	●	○	○
11	●	●	○	●	○	○
12	○	○	●	●	○	○
13	●	○	●	●	○	○
14	○	●	●	●	○	○
15	●	●	●	●	○	○
16	○	○	○	○	●	○
17	●	○	○	○	●	○
18	○	●	○	○	●	○
19	●	●	○	○	●	○
20	○	○	●	○	●	○
21	●	○	●	○	●	○
22	○	●	●	○	●	○
23	●	●	●	○	●	○
24	○	○	○	●	●	○
25	●	○	○	●	●	○
26	○	●	○	●	●	○
27	●	●	○	●	●	○
28	○	○	●	●	●	○
29	●	○	●	●	●	○
30	○	●	●	●	●	○
31	●	●	●	●	●	○
32	○	○	○	○	○	●
33	●	○	○	○	○	●
34	○	●	○	○	○	●

35	●	●	○	○	○	●
36	○	○	●	○	○	●
37	●	○	●	○	○	●
38	○	●	●	○	○	●
39	●	●	●	○	○	●
40	○	○	○	●	○	●
41	●	○	○	●	○	●
42	○	●	○	●	○	●
43	●	●	○	●	○	●
44	○	○	●	●	○	●
45	●	○	●	●	○	●
46	○	●	●	●	○	●
47	●	●	●	●	○	●
48	○	○	○	○	●	●
49	●	○	○	○	●	●
50	○	●	○	○	●	●
51	●	●	○	○	●	●
52	○	○	●	○	●	●
53	●	○	●	○	●	●
54	○	●	●	○	●	●
55	●	●	●	○	●	●
56	○	○	○	●	●	●
57	●	○	○	●	●	●
58	○	●	○	●	●	●
59	●	●	○	●	●	●
60	○	○	●	●	●	●
61	●	○	●	●	●	●
62	○	●	●	●	●	●
63	●	●	●	●	●	●

Field setting

Setting the filter indication interval

The FILTER indication interval on the remote control switch can be set at every 100, 1,200 or 2,500 hours (factory setting: 1200 hours). If 100, 1,200 or 2,500 hours' interval is required, follow the instructions below.

1. Press and hold (menu) and (return) simultaneously for at least 3 seconds during the normal mode (when unit is not operated). The test run menu will be displayed.
2. Select 'Optional Setting' from the test run menu pressing .
3. Select the indoor unit by pressing $\wedge \vee < >$ and press . (This screen is NOT displayed when the number of indoor unit connected with the remote control switch is 1 (one). In this case, (4) will be displayed.)
4. Press $\wedge \vee$ and select the item.
5. Press $< >$ and change the setting.

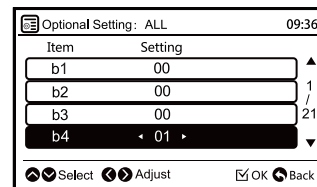
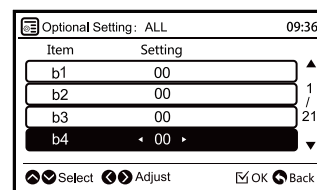
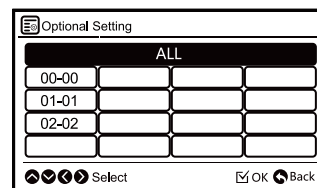
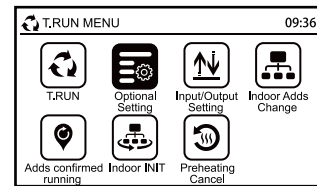

FILTER indication interval				
Approx. 100hr	Approx. 1,200hr	Approx. 1,200hr	Approx. 2,500hr	No indication
b4 01	b4 00(*)	b4 02	b4 03	b4 04

(*) Standard

6. Press so that the confirmation screen will be displayed.
7. Select 'Yes' and press . The test run menu will be displayed after the setting is confirmed. If 'NO' is pressed, the screen will return to (4).
8. Press (return) on the test run menu to return to the normal mode.

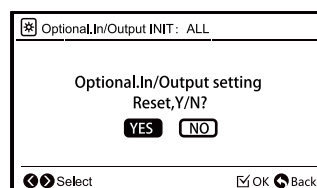





To set other units, press (return) at (4) (5) so that the screen will return to (3). (If the number of indoor unit connected with the remote control switch is 1 (one), the screen will return to (1)).

Field setting

Indoor unit address

Indoor unit address change.

1. Press and hold  (menu) and  (return) simultaneously for at least 3 seconds during the normal mode (when unit is not operated). The test run menu will be displayed.
2. Select 'Indoor Adds Change' from the test run menu pressing $\wedge \vee < >$ and .
3. Select the indoor unit by pressing $\wedge \vee < >$ and press .

*Indoor units which are not supporting " Indoor Adds Change "function can not be selected.

4. Determine the new indoor unit address. Press $\wedge \vee < >$ to switch the refrigerant cycle number and address in range of 00-63.
To display confirmation screen press .



* 'R.N No.99' is used temporarily address only when all the cycle numbers and unit numbers are in use (occupied).

If 'R.N No.99' is used temporarily, the address must be changed within the standard range of 00-63.

5. The confirmation screen will be displayed. Select 'Yes' and press  to started address change process. Result will be displayed in seconds. If 'No' is pressed, the screen will go to (6).

*When the process successfully completes 'Adds Change Ended' will be displayed.

Otherwise the process has been failed. Check the setting and contents again.

6. To change the address for another indoor unit, select 'Indoor Units Select' and press  the screen will return to (3). To finish this function select 'Adds Change Done' and press .

*If 'Indoor Adds Change' is successfully completed, connection check will be started automatically.

7. Turn OFF the power supply of the indoor units for 3-5 minutes. Wait until the remote control switches display turn off, and turn ON the power supply of indoor units again.

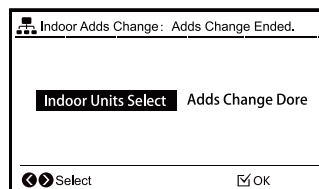
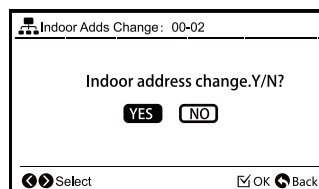
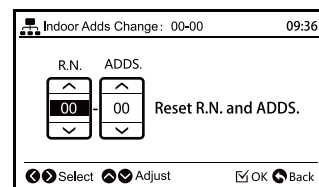
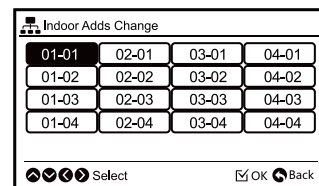
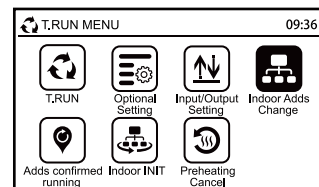

NOTE

'Indoor Adds Change' is not available when the control of 2 remote control switches (main and sub) are used.







Do not operate from the central controlling devices while 'Indoor Adds Change' is performed by the remote control switch.

This function should not be used if there is a Central Control in the H-NET.

Installation

Address check operation.



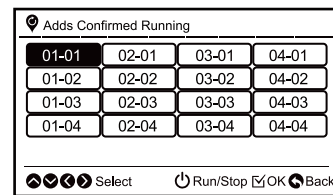
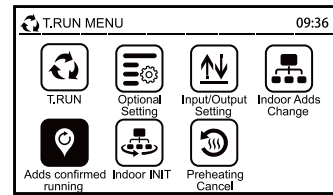

This function is used to check the relation between the indoor unit and I.U. address. This operation is effective when multiple indoor units are connected to the remote control switch and address of the certain unit is unknown.

1. Press and hold  (menu) and  (return) simultaneously for at least 3 seconds during the normal mode (when unit is not operated). The test run menu will be displayed.
2. Select 'Adds confirmed running' from the test run menu pressing $\wedge \vee < >$ and .
3. Select the indoor unit by pressing $\wedge \vee < >$.
4. To start operation of the indoor unit selected in (3) press  (run/stop). To return to (3) screen press  (run/ stop) while indoor units is operated.
- * Repeat (3)-(4) until desired indoor unit address is confirmed.
5. To return to the test run menu press  (return) while indoor unit is not operated.



Indoor unit address initialisation

This function initialises the indoor unit address that has been changed by 'Indoor Adds Change' function or set by the automatic address a location. Initialising the address will be changed to the dip switch setting.

1. Press and hold  (menu) and  (return) simultaneously for at least 3 seconds during the normal mode (when unit is not operated). The test run menu will be displayed.
2. Select 'Indoor INIT' from the test run menu pressing $\wedge \vee < >$ and $\wedge \vee < >$
3. Select the 'Reset Indoor Adds' by pressing $\wedge \vee$ and press .
4. Select the indoor unit by pressing $\wedge \vee < >$ and press . The confirmation screen will be displayed.

*Indoor units which are not supporting 'Reset Indoor Adds' function can not be selected.

The address of indoor unit that does not support 'Reset Indoor Adds' function will not be initialised even when 'All' is specified.

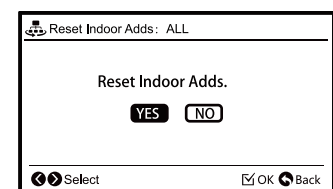
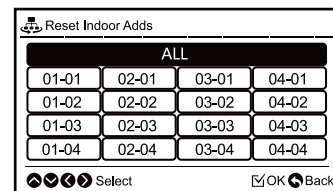
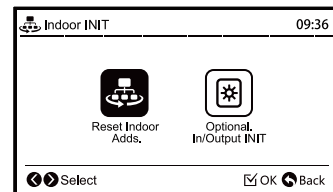
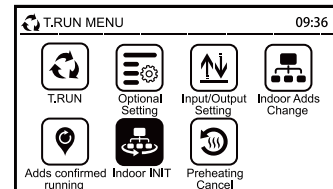

(5) Select 'Yes' and press  to start the address initialisation process.

*If the address initialisation is successfully completed, connection check will be started automatically.



Functions

Setting automatic swing louver

When the "louver" switch is pressed, the swing louver begins operating. When the  symbol is moving, it indicates the louver is swinging continuously. To stop the swinging motion, press the "louver" switch again. The louver will stop at the angle indicated by the direction of the  symbol.

NOTE

1. There may be a slight delay between the actual angle of the louver and the liquid crystal display.
2. When the "louver" switch is pressed to stop, the louver may complete one additional swing before stopping.
3. During the start-up of heating or defrosting operation, the discharge air angle is fixed in a horizontal position. The louvers will begin swinging when the outlet air temperature exceeds approximately 30°C.
4. During the defrosting operation, fan stops running.

CAUTION

Do not adjust the air louver by hand.
Manually moving the louver may damage the mechanism.

Automatic control

The system is equipped with the following functions.

- **Three Minute Guard (Enforced Stoppage)**
The compressor remains off for at least three minutes after it stops. If the system is restarted within approximately three minutes, the RUN indicator is activated, but cooling or heating operation will not begin until the three-minute delay has passed.
- **Three Minute Guard (Enforced Operation)**
If all indoor units are in Thermo-OFF mode within approximately three minutes after the compressor starts, the compressor will continue operating for a full three minutes. However, if all indoor units are turned off via the remote control, the compressor will stop.
- **Oil Return Operation**
If an indoor unit remains off for more than two consecutive hours, this function activates for a few minutes to prevent oil accumulation in the heat exchanger of the idle indoor unit during cooling operation.
- **Frost Prevention During Cooling Operation**
When the indoor unit operates at a low discharge air temperature, the cooling operation may temporarily switch to fan mode to prevent frost from forming on the indoor heat exchanger.
- **Hot Start During Heating Operation**
To prevent cold air from being discharged into the room, the fan starts at a low speed and gradually increases based on the discharge air temperature. During this time, the louver remains fixed in a horizontal position.
- **Slow Air Control During Defrosting Operation**
When the outdoor unit performs automatic defrosting, the indoor fan stops and the louver remains fixed in a horizontal position.
- **Cooling of Indoor Unit**
When heating is stopped, the indoor fan continues operating at a low speed for up to two minutes to reduce the temperature of the indoor unit.
- **Automatic Defrosting Cycle**
When heating is stopped by pressing the RUN/STOP switch, the system checks for frosting on the outdoor unit. If needed, defrosting may occur for up to 10 minutes.
- **Prevention of Overload Operation**
During heating operation in high outdoor temperatures, the outdoor thermistor may stop heating operation to prevent overload. Heating will resume once the temperature drops.

Cleaning and troubleshooting

Filter cleaning

⚠ CAUTION

Do not operate the system without the air filter. Operating without the air filter may cause the indoor unit heat exchanger to become clogged.

Always turn off the main power switch before removing the filter. (Note: The previous operation mode may appear when power is restored.)

Taking out the filter

The "FILTER" indication appears on the remote control display after approximately 1,200 hours of operation. Please remove and clean the air filter by following these steps:

1. Open the air inlet grille.
2. Take out the air filter from the air inlet grille.

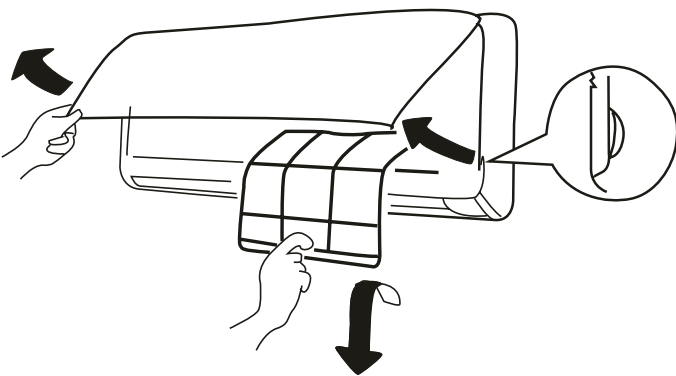

Clean the filter

Clean the air filter according to the following steps.

1. Use a vacuum cleaner or let water flow onto the air filter for removing the dirt from the air filter.

⚠ CAUTION

Do not use hot water higher than approximately 40°C.

2. Dry the air filter in the shade after shaking off moisture.

Reset the filter indication

After cleaning the air filter, press the "FILTER RESET" button. The FILTER indication will disappear and the next filter cleaning time will be set.

Troubleshooting

⚠ CAUTION

- If water overflows from the indoor unit's drain stop operation, immediately and contact your contractor.
- If you smell or see white smoke coming from the unit, switch off the main power supply and contact your contractor.

If the problem persists

If the issue continues, contact your supplier and provide the following information:

1. Unit model name
2. Description of the issue
3. Alarm code number displayed on the screen

No operation

Check the set temperature is correctly configured.

Not cooling or heating well

- Check for any obstructions blocking the airflow of the indoor or outdoor units.
- Ensure there are not too many heat sources in the room.
- Check if the air filter is clogged with dust.
- Verify that the doors and windows are closed.
- Confirm that the temperature is within the unit's operating range.

These are not abnormal

- Smells from indoor unit
Odours may cling to the indoor unit over time. Clean the air filter and panels, or ventilate the room well.
- Sound from deforming parts
A creaking or abrading sound may occur when the system starts or stops. This is caused by the thermal expansion or contraction of plastic components and is not a fault.
- Steam from outdoor heat exchanger
During defrosting, ice on the outdoor heat exchanger melts, creating visible steam. This is normal.
- Condensation on the air panel
If cooling continues for an extended period in high humidity conditions (above 27°C and 80% relative humidity), condensation may form on the air panel.
- Refrigerant flow noise
A flowing sound may be heard when the system starts or stops. This is due to refrigerant movement and is not a malfunction.

After sales service

If your air conditioner can not operate normally, turn off the unit and cut off the power supply at immediately.

Contact your service center or technical department.

emerald.com.au/contact

Emerald Energy Pty Ltd

ABN 86 632 172 368

L2, 12a Rodborough Road Frenchs Forest NSW 2086