

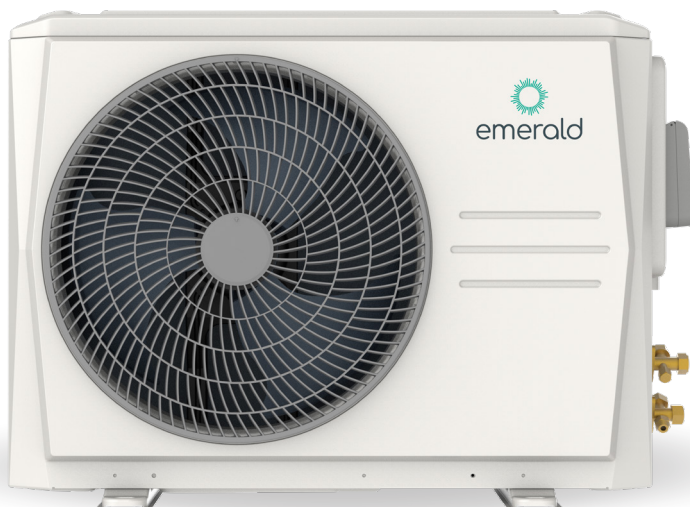

# User guide and installation manual

## Split System Pro Hot Water Heat Pump

HPRX300E-1



### IMPORTANT NOTICE

Please read this manual before installing the product and retain for future use. Not following the instructions may result in the product not functioning as intended.

# Welcome to your Emerald hot water heat pump

Engineered to minimise its environmental impact, your Emerald heat pump utilises R290, a natural and non-toxic refrigerant with minimal environmental harm. R290 has zero Ozone Depletion Potential (ODP) and an extremely low Global Warming Potential (GWP) of 3.

Emerald hot water heat pump's can save up to 80% on your hot water costs while enjoying efficient and eco-friendly hot water heating.

Unlike standard electric water heaters, Emerald heat pumps leverage advanced technology to extract heat from the air, delivering exceptional energy and cost savings.

## Registering your warranty gives you more from Emerald

- Priority customer support.
- Tips and advice to maximise savings with your Emerald heat pump.
- Exclusive product updates and promotions.
- Peace of mind knowing your hot water heat pump is protected.

Visit [emerald.com.au/warranty](https://emerald.com.au/warranty) and follow the instructions to complete the warranty registration.

Register now

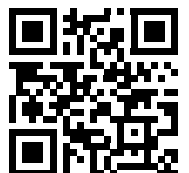

# User guide

## Operation instructions

|                        |   |
|------------------------|---|
| Control panel          | 4 |
| Display                | 4 |
| Keyboard               | 5 |
| Operating instructions | 5 |

---

|  |    |
|--|----|
| <b>Error and other codes explanation</b> | 23 |
|--|----|

---

|                   |    |
|-------------------|----|
| <b>Operations</b> | 24 |
|-------------------|----|

Installer reference code\*

## Installer information

Installer company:

---

Contact number:

---

Installer full name:

---

Install date:

---

Notes:

---

---

---

---

**Important notice:** Please read this manual before installing the product and retain for future use. Not following the instructions may result in the product not functioning as intended.

# Operation instructions

## Control panel

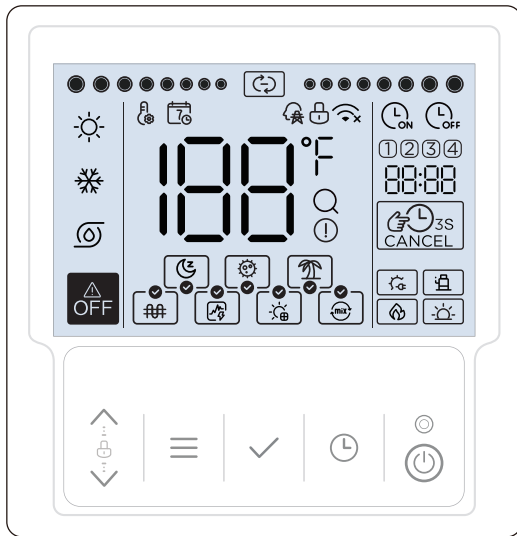

## Display

| ICON | NAME                      | DESCRIPTION  |
|------|---------------------------|--|
|      | Domestic hot water mode   | Will be lightened when the setting operating mode is domestic hot water mode (DHW mode), otherwise it will be extinguished.  |
|      | Silence function          | Will be lightened when the silence function is activated, and extinguished when the silence function is not activated. When it is selected (not activated), the icon will slowly flash. If manual disinfection function is activated, the icon will quickly flash in main interface.   |
|      | Disinfection function     | Will be lightened when the disinfection function is activated, and extinguished when the disinfection function is not activated. When it is selected (not activated), the icon will slowly flash. If manual disinfection function is activated, icon will quickly flash in main interface.   |
|      | Holiday away function     | Will be lightened when the holiday-away function is activated, and extinguished when the holiday-away function is not activated. When it is selected (not activated), the icon will slowly flash.  |
|      | Boost function            | Will be lightened when the boost function is activated, and extinguished when the boost function is not activated. When it is selected (not activated), the icon will slowly flash. If manual boost function is activated, icon will quickly flash in main interface. If the disinfection and boost functions are activated together, these two icons will be displayed alternately. |
|      | Manual e-heating function | Will be lightened and quickly flash when the manual e-heating function is activated, and extinguished when the manual e-heating function is not activated. When it is selected (not activated), the icon will slowly flash.  |
|      | OPT.Backup function       | Will be lightened when the OPT.Backup function is activated, and extinguished when the OPT.Backup function is not activated. When it is selected (not activated), the icon will slowly flash.  |
|      | Solar-energyfunction      | Will be lightened when the solar-energy function is activated, and extinguished when the solar-energy function is not activated. When it is selected (not activated), the icon will slowly flash.  |
|      | Hybrid function           | Will be lightened when the hybrid function is activated, and extinguished when the hybrid function is not activated. When it is selected (not activated), the icon will slowly flash.  |

## Display panel

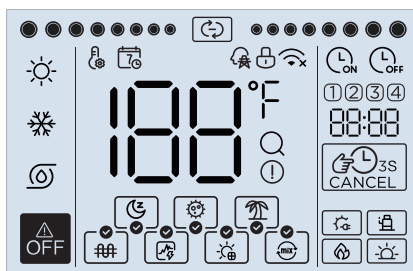

# Operation instructions

## Display (continued)

| ICON | NAME                  | DESCRIPTION   |
|------|-----------------------|---|
|      | OFF icon              | Will be lightened when user turns off the controller or selects OFF mode in some timers.  |
|      | Operating icon        | Will only be dynamically lightened when the unit is operating.  |
|      | Setting icon          | Will only be lightened when setting or adjusting.   |
|      | Weekly-schedule icon  | It will be lightened when weekly-schedule is activated in the app, and extinguished when the weekly-schedule is not activated.                      |
|      | Smart-grid icon       | Will be lightened when smart-grid function is activated, and extinguished when the smart-grid function is not activated.                            |
|      | Lock icon             | Will only be lightened when keyboard has been locked.   |
|      | Temperature icon      | Will display current tank temperature (DHW mode) at main interface, or display setting parameters when setting.                                     |
|      | Temperature-unit icon | Will display C° or F° when  display temperature.  |
|      | Query icon            | Will only be lightened during querying.   |
|      | Alarm icon            | Will quickly flash when a fault occurs.   |
|      | Boiler icon           | When this icon is lightened, it is recommended to turn on the boiler.   |
|      | Solar icon            | Will be lightened when solar energy signal is on.   |
|      | E-heater icon         | Will be lightened when the e-heater is operating.   |
|      | Heat-pump icon        | Will be lightened when the compressor is operating.   |
|      | Cancel icon           | Will be lightened when the timer or buzzer can be cancel.   |
|      | Timer-on icon         | Will be lightened when setting timer on clock.  |
|      | Timer-off icon        | Will be lightened when setting timer off clock.   |
|      | Clock icon            | Will display clock at the main interface normally, and display error code when fault occurs, and display other parameters when querying or setting. |
|      | Timer icon            | Will be lightened when corresponding timer is activated.  |

## Keyboard

| ICON | NAME                     | DESCRIPTION   |
|------|--------------------------|---|
|      | Adjustment buttons       | For adjusting parameters, moving cursor and so on.  |
|      | Menu button              | For entering or quitting menus.   |
|      | Confirm button           | For confirming settings and entering manual functions.  |
|      | Clock/Timer clock button | For setting clock or timer.   |
|      | ON/OFF button            | Turns the unit on or off. The LED indicator lights up when the unit is on and turns off when the unit is off. |

## Operation

### Installation settings

Up to 20 items can be set up. The items include:

- |                    |                                 |
|--------------------|---------------------------------|
| 1 Network          | 11 Smart grid                   |
| 2 Timer type       | 12 Tank volume                  |
| 3 Temperature unit | 13 Manually defrost             |
| 4 Silence          | 14 Refrigerant recovery         |
| 5 Disinfection     | 15 Power consumption estimation |
| 6 Holiday away     | 16 Operating time statistics    |
| 7 OPT.Backup       | 17 Unit address (reserve)       |
| 8 Solar energy     | 18 Clock correction             |
| 9 Hybrid           | 27 Validity period setting      |
| 10 Boost           | 28 E-heater reset               |

All of these modes are one-shot functions and will return to standard mode once complete or will reset to default settings at mid night 00:00.

In these items, only one of 7-OPT.Backup, 8-Solar energy and 11-Smart grid can be set as valid.

Press and hold ++ for 3 seconds to enter installation settings, then switch and select item number by / buttons. Then press button to enter the corresponding item setting or press button to quit installation settings (the parameters which do not need to be confirmed will not be saved).

Setting method shown on following pages.

# Operation instructions



Long press  $\wedge + \vee + \text{⏻}$  for 3 sec. to enter installation item selection interface, the interface will display item code (number).



Press  $\equiv$  button to quit the installation setting interface and return to main interface.

Press  $\wedge \vee$  buttons to change different item code (1~28).  
Press  $\checkmark$  button to enter the selected function settings.

## Network setting

In the installation item selection interface, press  $\wedge \vee$  buttons to select the item code 1.

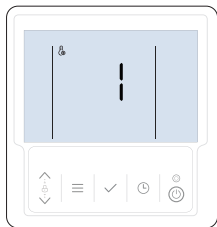

Press  $\checkmark$  button to enter the network function settings.

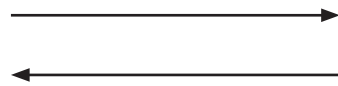

Press  $\equiv$  button to return to item selection interface without saving parameters.

Press  $\wedge \vee$  buttons to set network function on (ON) or off (OFF), and the selected code (ON or OFF) will flash slowly.

If the network function is off, press  $\checkmark$  button to return to Installation item selection interface and the network will be set to the local control mode automatically.

If the network function is on, press  $\checkmark$  button to enter the control mode setting interface, then press  $\wedge \vee$  buttons to select network control mode, and the selected code (LC, NC or LC:NC) will flash slowly.

Press  $\checkmark$  button to confirm control mode and return to installation item selection interface.

Press  $\equiv$  button to return to item selection interface without changing the control mode.

The code LC means all control functions are only in controller, and network user can only view the parameters.

The code NC means all control functions are only on network, and the controller will be only used to view the parameters.

The code LC:NC means all control functions can be used in both the controller and network, the unit will execute latest command.

## Timer type setting

In the installation item selection interface, press  $\wedge \vee$  buttons to select the item code 2.

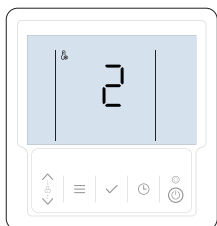

Press  $\checkmark$  button to enter the network function settings.

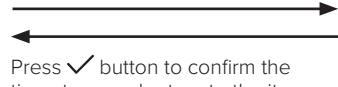

Press  $\checkmark$  button to confirm the timer type and return to the item selection interface.

Press  $\equiv$  button to return to item selection interface and do not change the timer type.

Press  $\wedge \vee$  buttons to set timer type (1~3), and the selected number code will flash slowly.

Timer code 1 means point timer (default), and timer code 2 means period timer, and timer code 3 means appointment timer. The specific differences and setting methods of these three timer type will be explained later.

# Operation instructions

## Temperature unit setting

In the installation item selection interface, press  $\wedge$   $\vee$  buttons to select the item code 3.

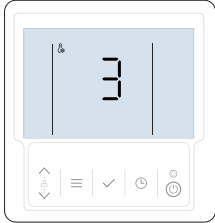

Press  $\checkmark$  button to enter the temperature unit type setting.

Press  $\checkmark$  button to confirm the unit type and return to the item selection interface.

Press  $\equiv$  button to return to item selection interface without saving parameters.

Press  $\wedge$   $\vee$  buttons to set temperature unit ( $^{\circ}\text{C}$  or  $^{\circ}\text{F}$ ), and the selected code will flash slowly.

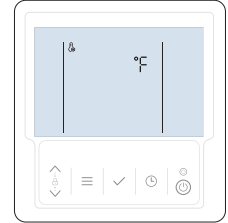
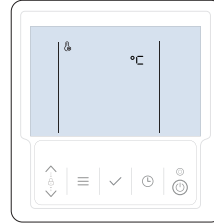

## Silence setting

In the installation item selection interface, press  $\wedge$   $\vee$  buttons to select the item code 4.

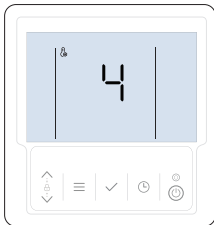

Press  $\checkmark$  button to enter the silence function settings.

Press  $\checkmark$  button to confirm the silence setting and return to the item selection interface.

Press  $\equiv$  button to return to item selection interface and do not change the silence type.

Press  $\wedge$   $\vee$  buttons to set silence function on (ON) or off (OFF), and the selected code (ON or OFF) will flash slowly.

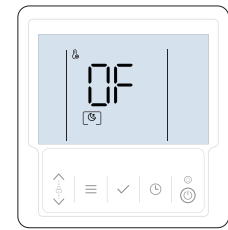
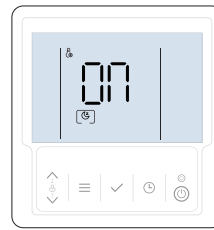

## Holiday away setting

In the installation item selection interface, press  $\wedge$   $\vee$  buttons to select the item code 6.

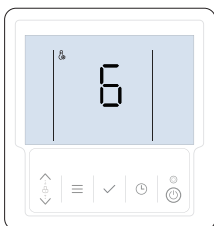

Press  $\checkmark$  button to enter the holiday away function settings.

Press  $\checkmark$  button to confirm the holiday away setting and return to the item selection interface.

Press  $\equiv$  button to return to item selection interface and do not change the silence type.

Press  $\wedge$   $\vee$  buttons to set holiday away function on (ON) or off (OFF), and the selected code (ON or OFF) will flash slowly.

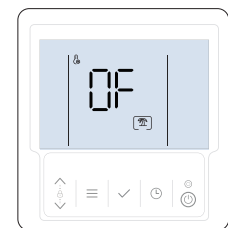
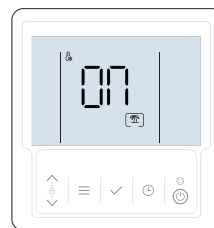

# Operation instructions

## Opt.Backup setting

In the installation item selection interface, press  $\wedge$   $\vee$  buttons to select the item code 7.

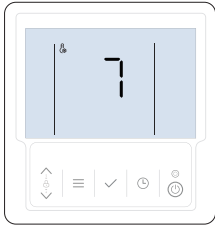

Press  $\checkmark$  button to enter the OPT. Backup setting.

Press  $\checkmark$  button to confirm the OPT.Backup setting and return to the item selection interface.

Press  $\equiv$  button to return to item selection interface and do not change the OPT.Backup.

Press  $\wedge$   $\vee$  buttons to set OPT.Backup function on (ON) or off (OFF), and the selected code (ON or OFF) will flash slowly.

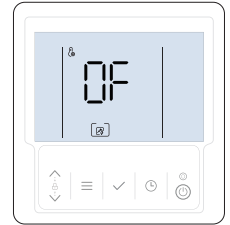
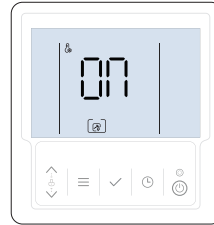

## Solar energy setting

In the installation item selection interface, press  $\wedge$   $\vee$  buttons to select the item code 8.

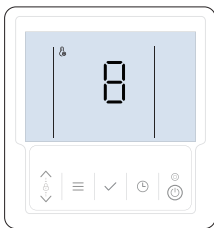

Press  $\checkmark$  button to enter the solar energy function setting.

Press  $\checkmark$  button to confirm the solar energy setting and return to the item selection interface.

Press  $\equiv$  button to return to item selection interface and do not change the solar energy.

Press  $\wedge$   $\vee$  buttons to set solar energy function on (ON) or off (OFF), and the selected code (ON or OFF) will flash slowly.

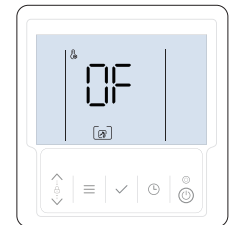
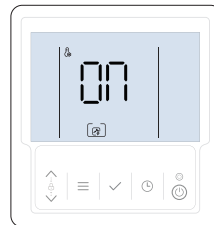

## Hybrid setting

In the installation item selection interface, press  $\wedge$   $\vee$  buttons to select the item code 9.

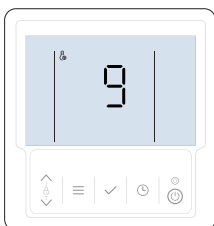

Press  $\checkmark$  button to enter the hybrid function setting.

Press  $\checkmark$  button to confirm the hybrid setting and return to the item selection interface.

Press  $\equiv$  button to return to item selection interface and do not change the hybrid setting.

Press  $\wedge$   $\vee$  buttons to set hybrid function on (ON) or off (OFF), and the selected code (ON or OFF) will flash slowly.

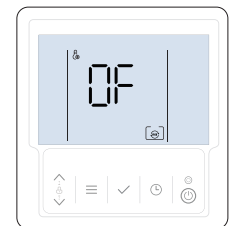
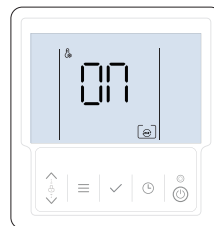

## Boost setting

In the installation item selection interface, press  $\wedge$   $\vee$  buttons to select the item code 10.

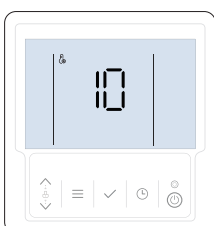

Press  $\checkmark$  button to enter the boost function setting.

Press  $\checkmark$  button to confirm the boost setting and return to the item selection interface.

Press  $\equiv$  button to return to item selection interface and do not change the boost setting.

Press  $\wedge$   $\vee$  buttons to set holiday away function on (ON) or off (OFF), and the selected code (ON or OFF) will flash slowly.

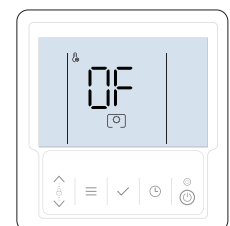
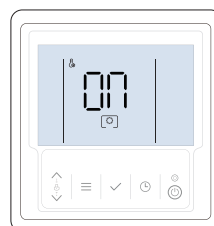

# Operation instructions

## Smart grid setting

In the installation item selection interface, press  $\wedge$   $\vee$  buttons to select the item code 11.

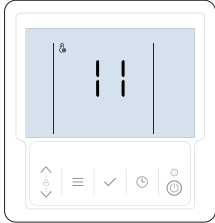

Press  $\checkmark$  button to enter the smart grid setting.

Press  $\checkmark$  button to confirm the smart grid setting and return to the item selection interface.

Press  $\equiv$  button to return to item selection interface and do not change the smart grid.

Press  $\wedge$   $\vee$  buttons to set smart grid function on (ON) or off (OFF), and the selected code (ON or OFF) will flash slowly.

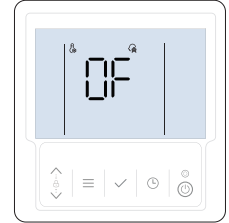
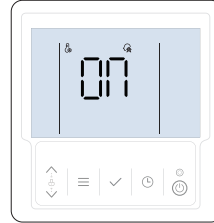

## Tank volume setting

In the installation item selection interface, press  $\wedge$   $\vee$  buttons to select the item code 12.

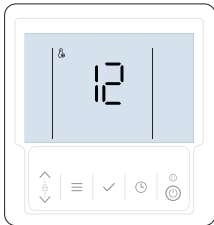

Press  $\checkmark$  button to enter the tank volume setting.

Press  $\checkmark$  button to confirm the tank volume setting and return to the item selection interface.

Press  $\equiv$  button to return to item selection interface and do not change the tank volume.

Press  $\wedge$   $\vee$  buttons to set silence function on (ON) or off (OFF), and the selected code (ON or OFF) will flash slowly.

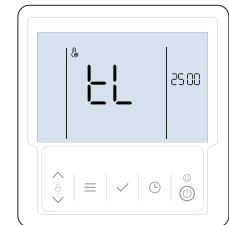
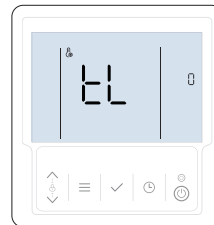

## Manual defrosting setting

In the installation item selection interface, press  $\wedge$   $\vee$  buttons to select the item code 15.

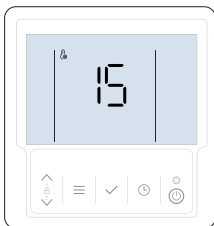

Press  $\checkmark$  button to enter the manual defrosting setting.

Press  $\equiv$  button to return to item selection interface and do not change manual defrosting function status.

Press  $\wedge$   $\vee$  buttons to set manual defrosting function on (ON) or off (OFF), and the selected code (ON or OFF) will flash slowly.

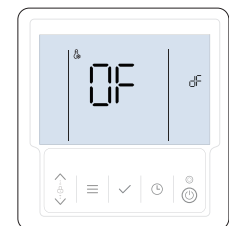
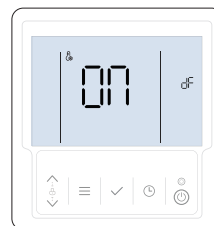

Press  $\checkmark$  button to confirm the manual defrosting setting and return to the main interface.

If on has been selected, code dF will be displayed at the temperature site in the main interface. Then the unit will go to defrost. The code dF will disappear after defrosting is finished or after turning off the unit.

If off has been selected, it will return to the main interface. Then the unit will quit defrosting and restore normal display.

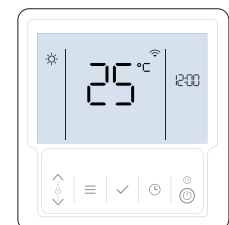
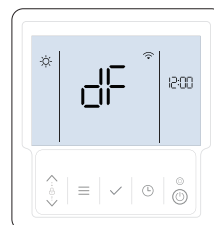

# Operation instructions

## Refrigerant recovery setting

In the installation item selection interface, press  $\wedge$   $\vee$  buttons to select the item code 18.

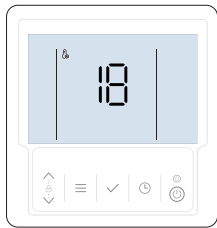

Press  $\checkmark$  button to enter the refrigerant recovery setting.

Press  $\equiv$  button to return to item selection interface and do not change refrigerant recovery function status.

Press  $\wedge$   $\vee$  buttons to set refrigerant recovery function on (01) or off (0F), and the selected code (01 or 0F) will flash slowly.

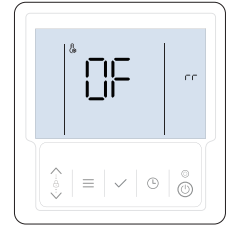
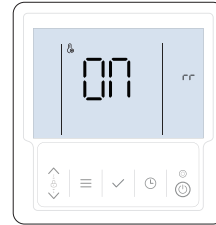

Press  $\checkmark$  button to confirm the refrigerant recovery setting and return to the main interface.

If on has been selected, code  $rr$  will be displayed at the temperature site in the main interface. Then the unit will go to defrost. The code  $rr$  will disappear after defrosting is finished or after turning off the unit.

If off has been selected, it will return to the main interface. Then the unit will quit defrosting and restore normal display.

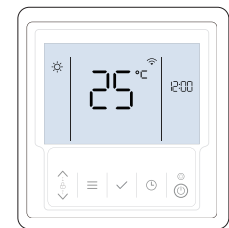
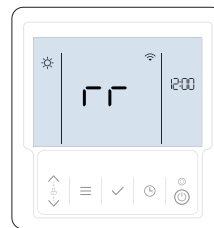

## Power consumption estimation setting

In the installation item selection interface, press  $\wedge$   $\vee$  buttons to select the item code 19.

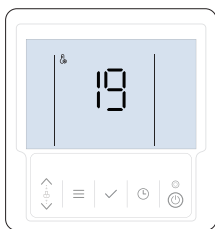

Press  $\checkmark$  button to enter power consumption estimation setting.

Press  $\checkmark$  button to confirm this function and return to the item selection interface.

Press  $\equiv$  button to return to item selection interface and do not change the function status.

Press  $\wedge$   $\vee$  buttons to set power consumption estimation function on (01) or off (0F), and the selected code (01 or 0F) will flash slowly.

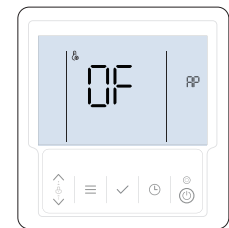
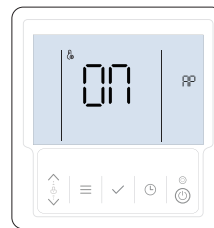

## Operating time statistics setting

In the installation item selection interface, press  $\wedge$   $\vee$  buttons to select the item code 20.

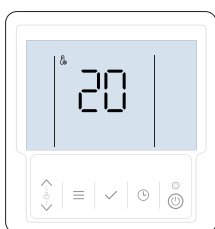

Press  $\checkmark$  button to enter the operating time statistics setting.

Press  $\checkmark$  button to confirm this function and return to the item selection interface.

Press  $\equiv$  button to return to item selection interface and do not change the function status.

Press  $\wedge$   $\vee$  buttons to set operating time statistics function on (01) or off (0F), and the selected code (01 or 0F) will flash slowly.

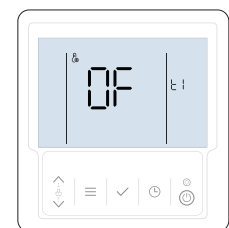
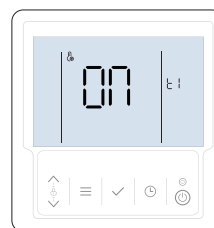

# Operation instructions

## Clock correction setting

In the installation item selection interface, press  $\wedge$ / $\vee$  buttons to select the item code 26 for the correction of Winter and Summer Time.

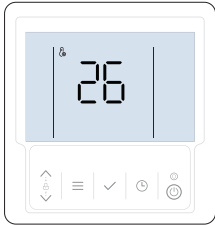

Press  $\checkmark$  button to enter clock correction setting.



Press  $\checkmark$  button to confirm clock correction setting and return to the item selection interface.

Press  $\equiv$  button to return to item selection interface and do not change the clock correction.

Press  $\wedge$ / $\vee$  buttons to set clock correction hours (range -5~5, default 0), and the correction hours will flash slowly.

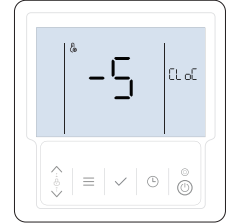
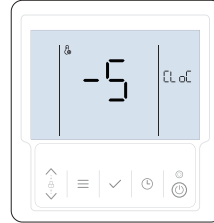

## Validity period setting

In the installation item selection interface, press  $\wedge$ / $\vee$  buttons to select the item code 27.

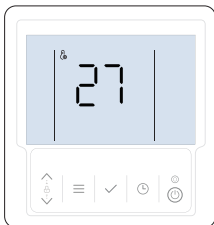

Press  $\checkmark$  button to enter the validity period setting.

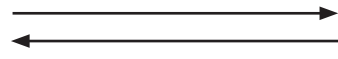

Press  $\checkmark$  button to confirm the validity period setting and return to the item selection interface.

Press  $\equiv$  button to return to item selection interface and do not change the validity period.

Press  $\wedge$ / $\vee$  buttons to set validity period within 24 hours (07) or long term (0F), and the selected code (07 or 0F) will flash slowly.

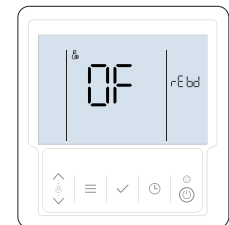
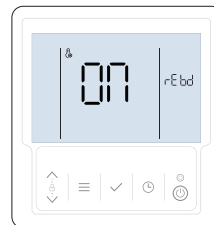

## E-heater reset

In the installation item selection interface, press  $\wedge$ / $\vee$  buttons to select the item code 28 for resetting E-heater as invalid.

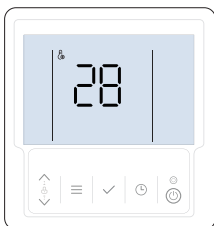

Press  $\checkmark$  button to enter the validity period setting.

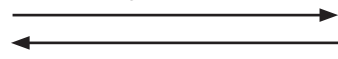

Press  $\checkmark$  button to confirm the validity period setting and return to the item selection interface.

Press  $\equiv$  button to return to item selection interface and do not change the validity period.

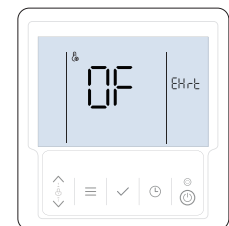
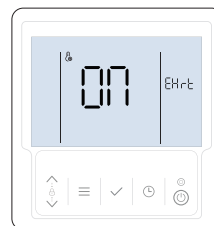

Press  $\wedge$ / $\vee$  buttons to set disinfection function on (07) or off (0F), and the selected code (07 or 0F) will flash slowly.



If selected on, the unit will reset the E-heater settings, then automatically self-check the E-heater after power on.

# Operation instructions

## Unlock/lock keyboard

When controller is locked and the  icon is lightened, any button is invalid at this time. Long press the  +  buttons for 1 sec. to unlock/lock the keyboard. The keyboard will be locked automatically when not operated for 2 minutes.

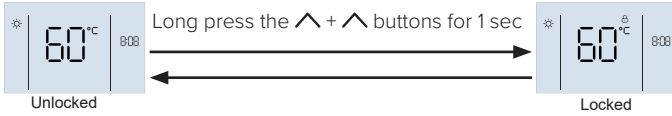

## Turn the unit on/off

Press the  button to turn on or turn off the unit, When the keyboard is unlocked.

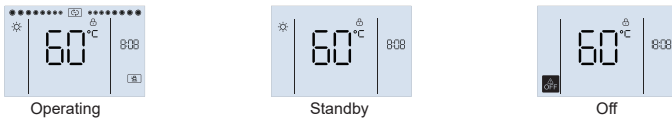

If unit is turned on and not operating, the main interface will display setting mode, current temperature, clock and so on. If unit is turned on and operating, the operating icon will flash. If unit is turned off, the  icon will be lightened and operating icon and mode icon will be distinguished.

Examples of operating, standby and OFF state:



## Operating mode and parameter setting

### 1. Restart offset temperature setting

The code  displayed at  means Trdh (restart offset temperature for domestic hot water mode), and the value displays at temperature site .

When the temperature of the water tank drops beyond Trdh, the unit will start heating.

The setting method is as follows:

### NOTE

1. If one function of OPT.Backup, timer, solar energy and smart grid has been activated, the actual Trdh is automatically set to no larger than the default value.
2. If no function of OPT.Backup, timer, solar energy and smart grid is activated, the actual Trdh is equal to the set value.

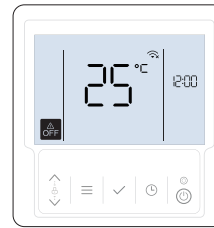

In the main interface, press the  button to enter the operating mode selecting interface, and the selected mode will flash slowly. For this unit, there is only domestic hot water mode to be selected.

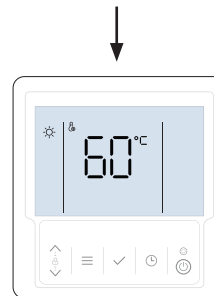

No button operation for 60 sec. to return to main interface (don't change setting mode).

Press  button to confirm the operating mode and return to main interface.

Press  button to go to function activation interface.

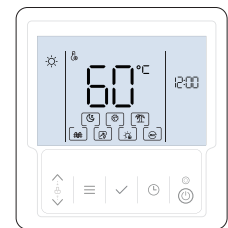

In the operating mode setting interface, long press  button for 3 sec. to enter Trdh value setting, and the setting value will flash slowly.

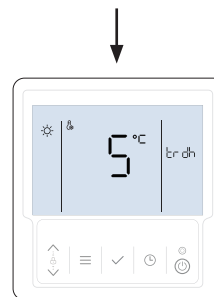

Press  button to confirm the setting Trdh and return to main interface.

Press  button or no button operation for 60 sec to return to main interface (don't change setting mode).

Press   buttons to set the restart offset temperature Trdh (range: 2~40°C, default: 5°C).

# Operation instructions

## 2. Parameters of E-heater setting

If the unit does not equip E-heater, these parameters can not be set. These parameters include Td (the lowest ambient temperature of auto-operating with heat pump and E-heater together, range -15~44°C, default 0°C, code **td** displays at **100**), TrEH (the restart offset temp. of E-heater, range 1~40°C, default 10°C, code **trEH** displays at **00:00**) and TsEH (the restart offset temperature of E-heater, range 0~39°C, default 0°C, the code **tsEH** displays at **00:00**).

Td is a limit value to determine if e-heater and heat pump can operate at the same time or not. If the ambient temperature is higher than or equal to Td, the unit will only start heat pump at first, then start e-heater after heat pump stopped if the water temperature does not reach target temperature (code: T5s) because that heat pump reached its highest water temperature (code: T5stop), or ambient temperature has be over the declared operating range, or some heat pump faults occurred. If the ambient temperature is lower than Td, the unit will only start heat pump at first, then start e-heater if the water temperature is lower than the difference between T5s and TrEH, and the heat pump will operate until water temperature reached T5stop (if T5stop is lower than T5s) or T5s (if T5stop is higher than T5s), and the e-heater will operate until the water temperature reached the difference between T5s and TsEH (if T5stop is higher than the difference between T5s and TsEH) or reached T5s (if T5stop is lower than the difference between T5s and TsEH).

During setting **00:00** displays Td value, and **100** displays code **td** (Td). The setting method is as follows:

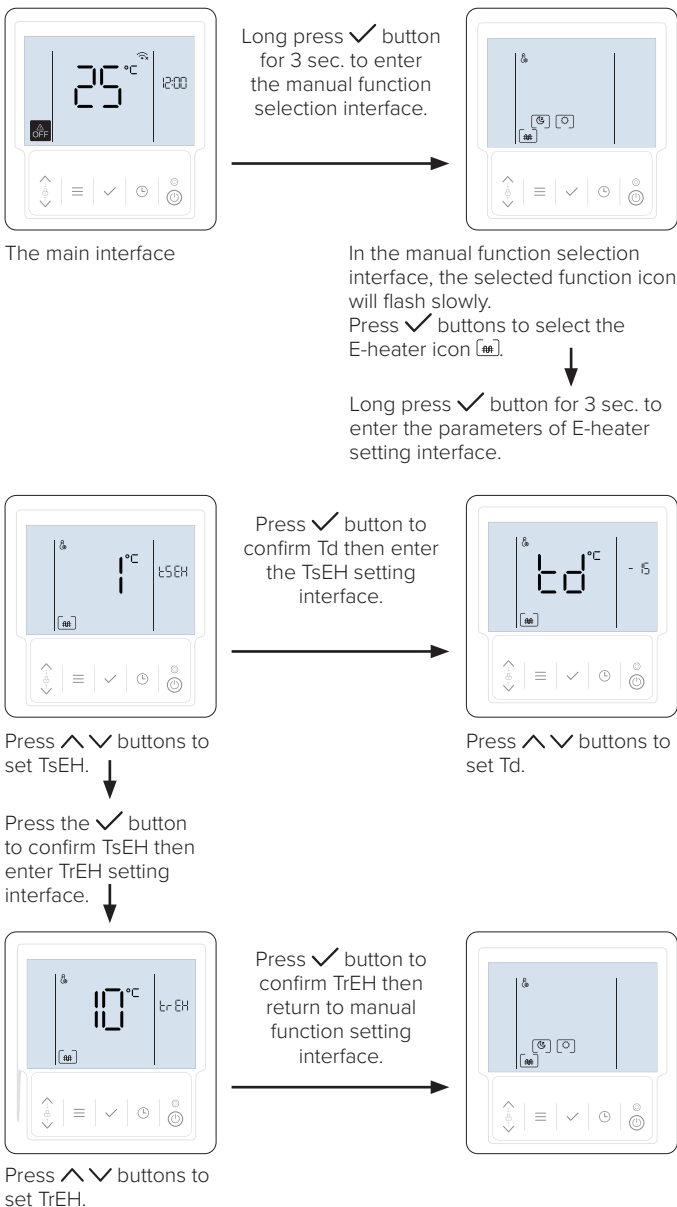

## Target temperature setting

In the main interface, press **^** **✓** buttons to adjust target temperature. During adjusting, press **≡** or **✓** button to confirm settings then return to main interface, or no press any button for 60 sec then confirm settings automatically and return to main interface.

Interface example:



# Operation instructions

## Clock setting

If the controller has successfully connected to network, it will update the clock automatically from network, else user can set clock in the controller. Only  icon and current setting parameters are lightened during clock setting.

If the controller does not get the correct time from the network after the first power on or a prolonged power outage, the clock will display 12:00 and flash slowly, prompting the user to set the correct time. When the user completes the time setting or the controller gets the time from the network, the clock will no longer flash and remain on.

The setting method is as follows: (For example: 2024.2.10 12:00)

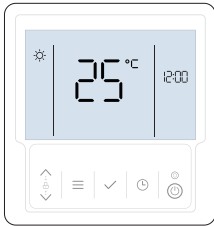



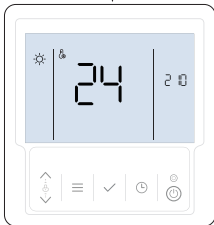

In the main interface, press  button for 3 sec. to enter clock setting, default enter year setting, and the year code number will flash slowly.

 **NOTE**



During setting, press  button to return to main interface without saving settings, or no button operation for 60 sec then confirm settings automatically and return to main interface.



Press   buttons to set year at  (only display tens and single digits, for example, 24 means the year 2024).

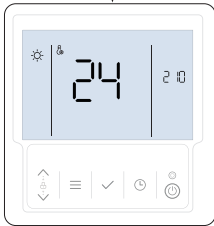

Then press  button to confirm year setting, then enter month setting, and the month code number will flash slowly.

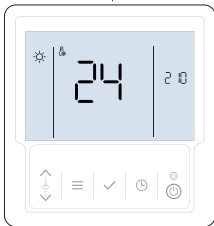

Press   buttons to set month at the first two of  i.e code 2 means February.

Press  button to confirm month setting, then enter day setting, and the day code number will flash slowly.





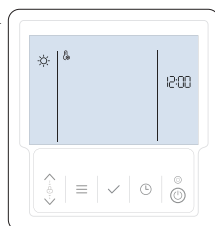

Press   buttons to set day at the last two of  i.e code 10 means 10th.

Press  button to confirm the date setting, then enter hour setting, and the hour code number will flash slowly.





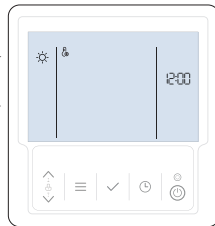

Press  button to switch between hour and minute.

Press   buttons to set minute at the last two of  i.e code 00 means 0 minute.

Press  button to confirm the minute setting, then return to main interface.





Press   buttons to set hour at the first two of  i.e 12 means 12 o'clock.

Press  button to confirm the hour setting, then enter minute setting, and the minute code number will flash slowly.

## Timer setting

There are 3 mutually exclusive type to set timer, including point timer, period timer, and appointment timer, which one is available depends on the installation settings. Only the activated timer numbers can be displayed in the main interface. The timer step is 10 min. in all timer type.

If the functions of manual on/off, daily timer and weekly schedule conflict, the priority is as follows: manual on/off > holiday away > weekly schedule > daily timer. In case of conflict between different timer numbers, the later set timer prevails and the previous conflicting setting is automatically set to inactive status.

After the timer settings are completed, the activated timer numbers are displayed at the main interface. When the clock reaches the timer point, according to the switching action at that time point,  or  will be lightened respectively and unit will execute the corresponding commands (on/off, target temperature).

 **NOTE**

1. If user changes the target temperature or manually turns on/off unit when the timer is already in effect, on this day the current timer will be invalidated until the time of next timer then executes the corresponding command according to the timer setting.  
  
For example (point timer), the user sets timer ① (5:00 on, target 55°C), timer ② (12:00 off), timer ③ (14:00 on, target 60°C). If user adjusts the target temperature to 60°C at 7:00, the target temperature will be set to 60°C directly until 12:00 then unit is turned off; if user manually turns off the unit at 7:00, the unit will be turned off immediately until 14:00 when timer ③ is executed.
2. For example (appointment timer), the user sets timer ① (12:00~14:00, target 50°C) and timer ② (20:00~23:00, target 60°C). If the user has adjusted target temperature at 7:00 (i.e. even if the final temp. is the same as the original target), the timer ① will be invalid on this day, and the unit will keep the current on/off status until 14:00 (the end of timer ①), if needing the unit to operate, please turn it on manually.
3. Under the timer, the  icon is displayed and the LED light is off when the unit is not turned on, and the run icon is displayed and the LED light is on when the unit is turned on.
3. If the time between timer on and off clocks is too short, it will cause that the unit fail to heat up to the set water temperature, so it is recommended that the total time between timer on and off clocks is longer than 8 hours.
4. The timer, solar energy, smart grid, and OPT.Backup functions are mutually exclusive, and the timer can only be used when these functions are not activated.

An interface example (No.1, No.3 and No.4 have been activated, but No.2 is not activated) is as follows:

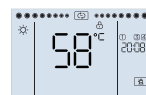

# Operation instructions

## 1. Point timer setting

There are 4 point timers in this type. Every timer includes the point clock, operating mode (including OFF mode), target temperature (except OFF mode). Controller will execute the setting action at the point clock.

It is possible to set the on/off timers in any combination (such as 4 on timers and 0 off timer, 3 on timers and 1 off timer, 2 on timers and 2 off timers, 1 on timer and 1 off timer, 2 on timers and 1 off timer, etc.), and it is recommended that the number of off timers be less than or equal to the number of on timers.

By different combinations of point timers, it is possible to avoid unsuitable operating periods, and to operate during periods with higher ambient temperatures or peak electricity hours.

Examples of point timer settings:

Example 1:

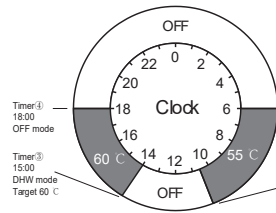

Example 2:

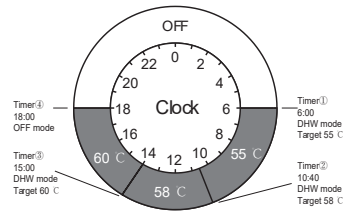

The setting method is as follows:

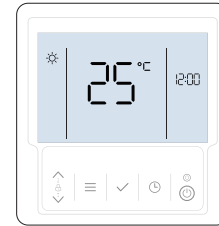

In the main interface, press the power button to enter timer setting, then display selecting number interface, and the timer code ① (default selected ①) will flash slowly.

If no timer has been set, only the timer code ① will be displayed and flash slowly.

If any timer has been set, the codes of set timers (such as ②④) will be displayed with the default selected ①, and the selected code will flash slowly.

Press the up/down buttons to select different timer codes. If the selected (such as ② or ④) timer has been set, the set parameters will be displayed.

For example, timer ② and ④ have been set, and timer ① and ③ have not been set, and timer ② has been selected now, so the code ② and ④ are displayed, and code ② is flash slowly, and the parameters of timer ② are displayed in the current interface.

For example, timer ② and ④ have been set, and timer ① and ③ have not been set, and timer ③ has been selected now, so the code ② and ④ are displayed, and code ③ is flash slowly.

Press the checkmark button to enter the parameter settings of the selected timer, and default to the hour of the timer clock, and the hour will flash slowly. Then press the up/down buttons to adjust hour or minute, press the power button to switch between hour and minute.

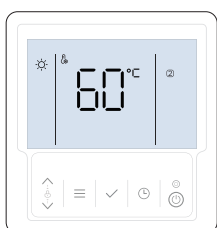

Press the up/down buttons to set the target temperature. Then press the checkmark button to confirm the settings and return to the timer code selecting interface.

Press the checkmark button to confirm the operating mode. If set the OFF mode then return to the timer code selecting interface, else enter the target temperature setting interface.

Press the up/down buttons to select the operating mode between domestic hot water mode and OFF mode.

Press the checkmark button to confirm the timer clock, then enter the operating mode setting.

# Operation instructions

## 2. Period timer setting

There are 4 period timers in this type. Every timer includes the on clock, off clock, operating mode, target temperature. Controller will execute the setting action at the period clocks. By different combinations of point timers, it is possible to avoid unsuitable operating periods, and to operate during periods with higher ambient temperatures or peak electricity hours.

The setting method is as follows:

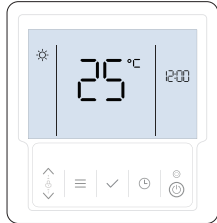
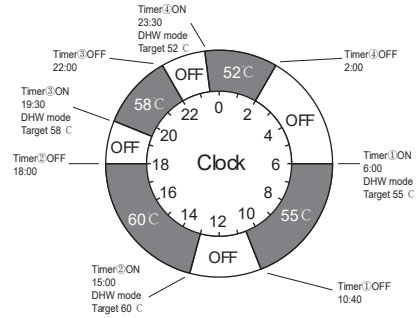

In the main interface, press **⏸** button to enter timer setting, then display selecting number interface, and the timer code **⓪** (default selected **Ⓠ**) will flash slowly.

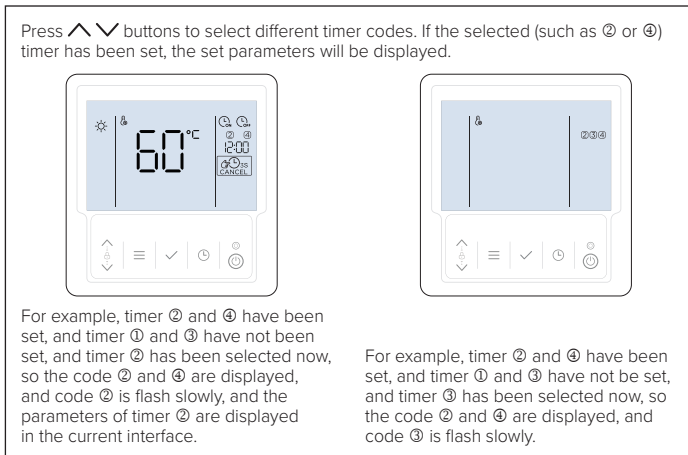
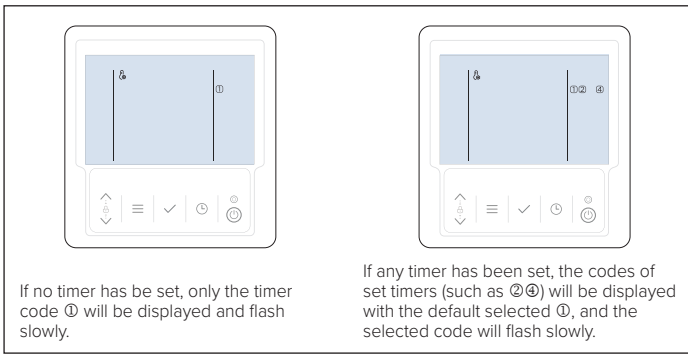

Press **✓** button to enter the on parameter settings of the selected timer, and default to the hour of the timer clock, and the hour will flash slowly, and the **🕒** icon will be lightened.

**NOTE**

- During setting, in the timer code selecting interface, when the icon **🕒** is displayed, long press **⏸** button for 3 sec. to cancel the selected timer, and the number will be distinguished.
- During setting, in the timer code selecting interface, press **≡** button to return to main interface, or no button operation for 60 sec then return to main interface, and do not change the activation of any unconfirmed point timer.
- During setting, in the parameters setting interface of timer, press **≡** button to return to selecting number interface, or no button operation for 60 sec then return to selecting number interface, and do not change any unconfirmed parameters.

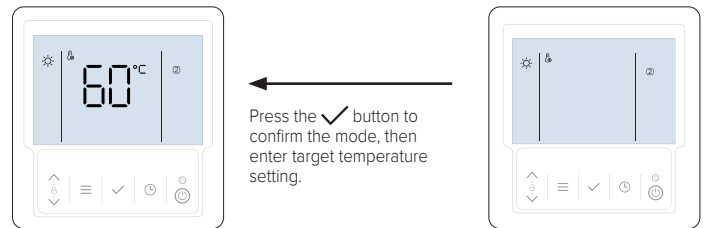

Press **▲**/**▼** buttons to set the target temperature. Then **✓** press button to confirm the settings and return to the timer code selecting interface.

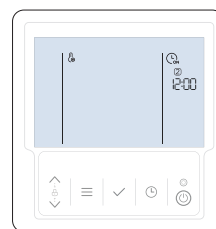
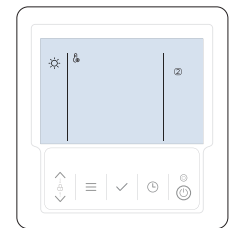

Press **▲**/**▼** buttons to adjust hour or minute, press **⏸** button to switch between hour and minute.

The default order is hours first and then minutes.

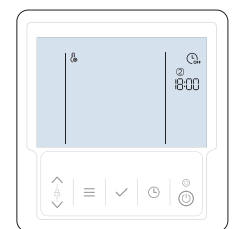

Press **▲**/**▼** buttons to adjust hour or minute, press **⏸** button to switch between hour and minute.

The default order is hours first and then minutes.

# Operation instructions

## 3. Appointment timer setting

There are 4 period timers in this type. Every timer includes the start and end clocks of water usage, operating mode and target temperature. Controller will send the setting parameters to unit, then unit will automatically calculate the heat up time according to these appointment parameters, ambient temperature and current water temperature, then automatically operate at a suitable time to heat the water up to target temperature before the start clock of water usage of the set timer.

By appointment timers, users do not need to worry about when to turn on or how long to ensure sufficient hot water usage. Users only need to tell the unit when to use water and how much water temperature, and the unit can intelligently determine the timing of turning on.

An example of period timer settings is as follows:

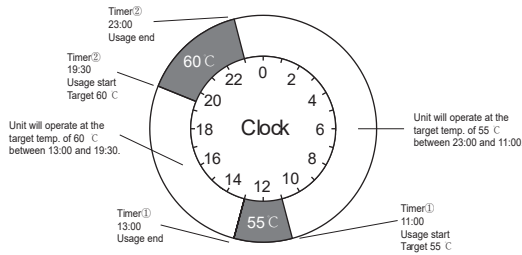

The setting method is as follows:

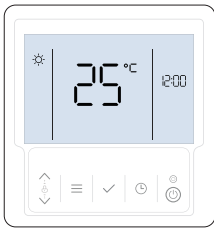

In the main interface, press  $\odot$  button to enter timer setting, then display selecting number interface, and the timer code  $\textcircled{1}$  (default selected  $\textcircled{1}$ ) will flash slowly.

If no timer has been set, only the timer code  $\textcircled{1}$  will be displayed and flash slowly.

If any timer has been set, the codes of set timers (such as  $\textcircled{2}$ ④) will be displayed with the default selected  $\textcircled{1}$ , and the selected code will flash slowly.

Press  $\wedge$   $\vee$  buttons to select different timer codes. If the selected (such as  $\textcircled{2}$  or  $\textcircled{4}$ ) timer has been set, the set parameters will be displayed.

For example, timer  $\textcircled{2}$  and  $\textcircled{4}$  have been set, and timer  $\textcircled{1}$  and  $\textcircled{3}$  have not been set, so the code  $\textcircled{2}$  and  $\textcircled{4}$  are displayed, and code  $\textcircled{2}$  is flash slowly, and the parameters of timer  $\textcircled{2}$  are displayed in the current interface.

For example, timer  $\textcircled{2}$  and  $\textcircled{4}$  have been set, and timer  $\textcircled{1}$  and  $\textcircled{3}$  have not been set, so the code  $\textcircled{2}$  and  $\textcircled{4}$  are displayed, and code  $\textcircled{3}$  is flash slowly.

Press  $\checkmark$  button to enter the on parameter settings of the selected timer, and default to the hour of the timer clock, and the hour will flash slowly, and the  $\textcircled{C}$  icon will be lightened.

**NOTE**

- The appointment is set for water usage time, not the on/off time of the unit.
- After completing the appointment timer setting, it is necessary to ensure that the controller is turned on (The LED above the ON/OFF button is lightened and the  $\text{OFF}$  icon is extinguished) for the timers to work. If the controller is in off state, please press the ON/OFF button to turn it on.
- The appointment function will be affected by water consumption, weather changes, using habits and other factors and may not fully achieve the desired results (including water temperature and power consumption), so please use with caution. It is recommended that setting no more than 2 appointments per day, with an interval of no less than 8 hours between appointments and no more than 4 hours per appointment to allow sufficient time for the unit to heat up.

**NOTE**

- During setting, in the timer code selection interface, when the icon  $\text{OFF}$  is displayed, long press  $\odot$  button for 3 sec. to cancel the selected timer, and the number will be distinguished.
- During setting, in the timer code selecting interface, press  $\equiv$  button to return to main interface, or no button operation for 60 sec then return to main interface, and do not change the activation of any unconfirmed point timer.
- During setting, in the parameters setting interface of timer, press  $\equiv$  button to return to selecting number interface, or no button operation for 60 sec then return to selecting number interface, and do not change any unconfirmed parameters.

Press  $\wedge$   $\vee$  buttons to set the target temperature. Then  $\checkmark$  press button to confirm the settings and return to the timer code selecting interface.

Press the  $\checkmark$  button to confirm the mode, then enter target temperature setting.

Press  $\wedge$   $\vee$  buttons to adjust hour or minute, press  $\odot$  button to switch between hour and minute. The default order is hours first and then minutes.

Press the  $\checkmark$  button to confirm the set clock.  $\checkmark$  After pressing the button in minutes, enter the OFF clock setting.

Press  $\wedge$   $\vee$  buttons to adjust hour or minute, press  $\odot$  button to switch between hour and minute. The default order is hours first and then minutes.

Press the  $\checkmark$  button to confirm the set clock, then enter the mode setting.

# Operation instructions

## Function activation and parameters setting

In the main interface, long press button for 3 sec. or press button twice to enter the function selection and activation interface. The available functions depend on the unit, including disinfection, holiday away, OPT.Backup, solar energy, silence, boost and hybrid. During setting, the selected function icon will slowly flash. For example, if disinfection function is not activated the icon will be lightened, and if it is activated the icon will be lightened, and if it is selected but not activated then the icon will slowly flash, and if it is selected and activated then the icon will slowly flash. Press button to activate or deactivate the selected function.

The setting method is as follows:

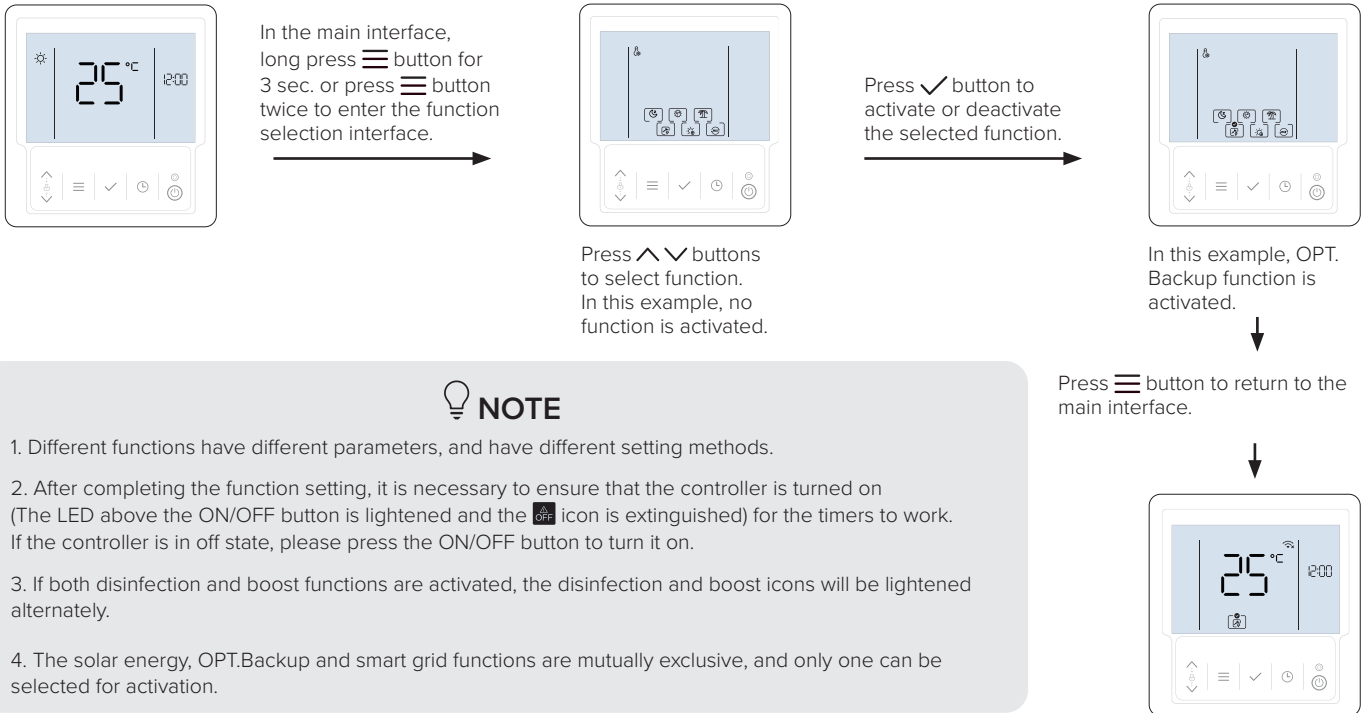

### 1. Holiday away activation/deactivation

Holiday away function allows user to set a holiday schedule (days of holiday away). During the holiday away period, the unit will be OFF or ON (the setting target temperature will be set to 25°C automatically,) which depends on the detail parameter settings of holiday away. At the last day of holiday, the unit will do disinfection once and recover the settings before holiday away.

Setting method:

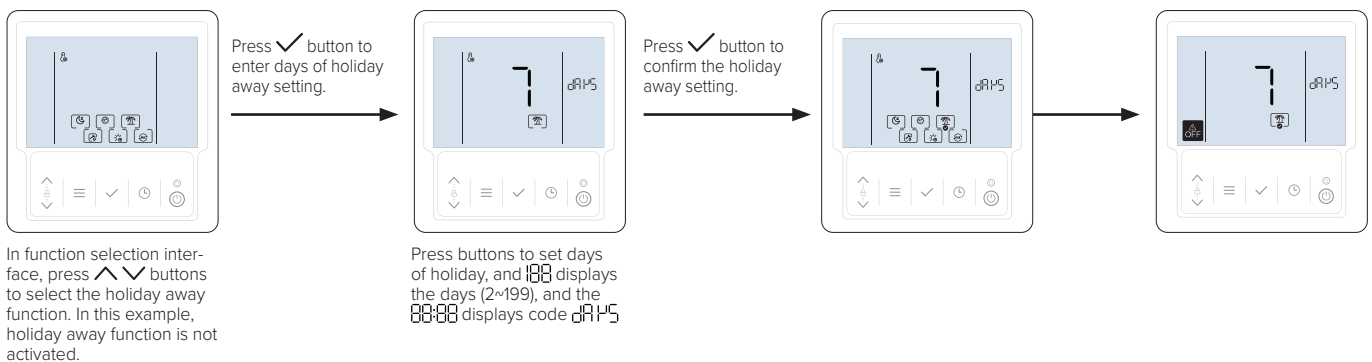

Method for manually canceling vacation function settings is as follows:

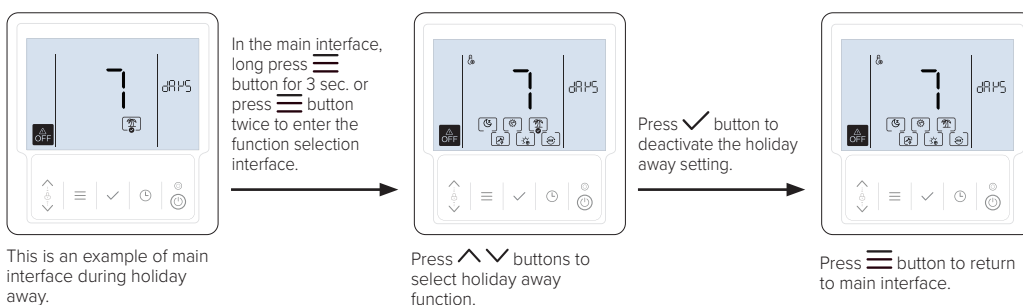

# Operation instructions

## 2. Disinfection parameters setting

Disinfection parameters setting includes disinfection clock, temperature and cycle time. During setting, 88:88 displays disinfection clock (step 10 min.) 60 displays disinfection temperature (55~70°C, default 60°C) and cycle days (2~30 days, default 7 days). After disinfection function being activated, unit will do disinfection (heat up the water to the set disinfection temperature) at the set clock every set cycle days.

The setting method is as follows:

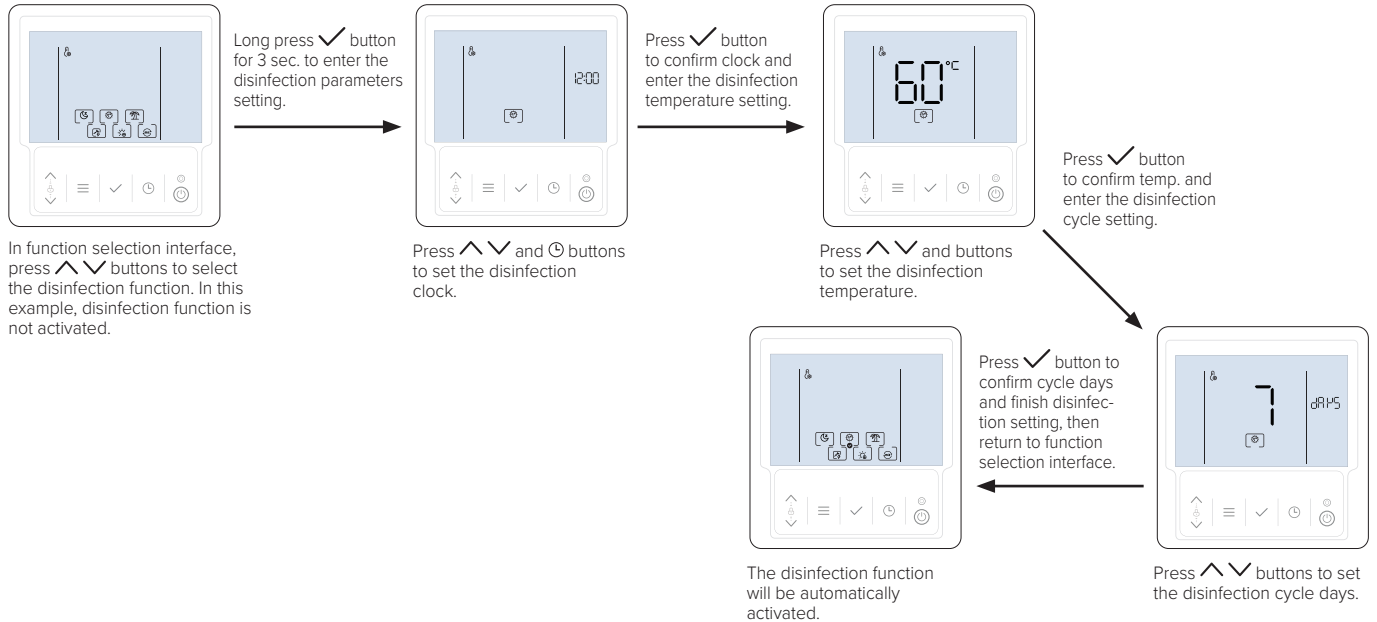

## 3. Holiday away parameter setting

Holiday away parameter is the operating mode (include OFF (OFF, default) and Auto (auto) mode, displayed at 88:88) during holiday. If the set mode is OFF, then the unit will be turned off during holiday. If the set mode is Auto, then the unit will be turned off or heat the water up to 25°C by the controller self-judgment for anti-freezing.

The setting method is as follows:

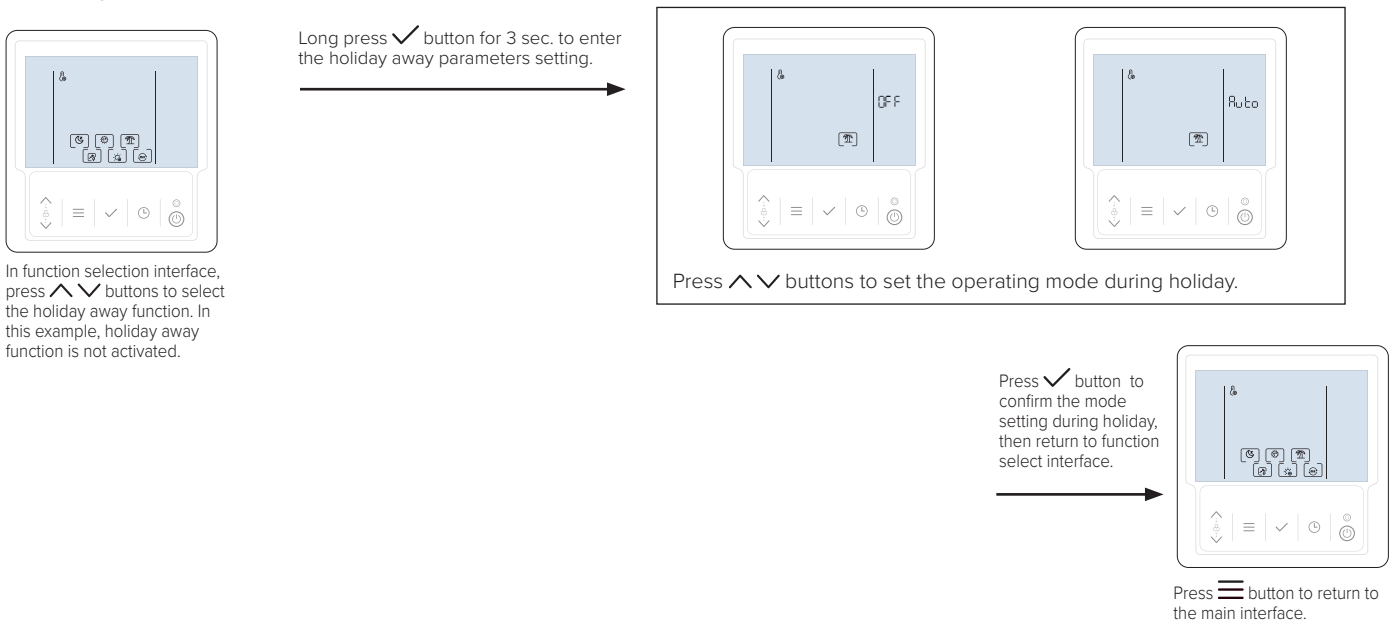

# Operation instructions

## 4. Solar energy parameter setting

Solar energy parameter is the operating mode (include PLUS (PLUS, default) and ONLY (ONLY) mode, displayed at 88:88) when the function is valid. If the set mode is PLUS, then the controller will increase the target temperature by 10°C automatically when the solar energy signal on. If the set mode is ONLY, then the controller will turn on the unit only when the solar energy signal on.

The setting method is as follows:

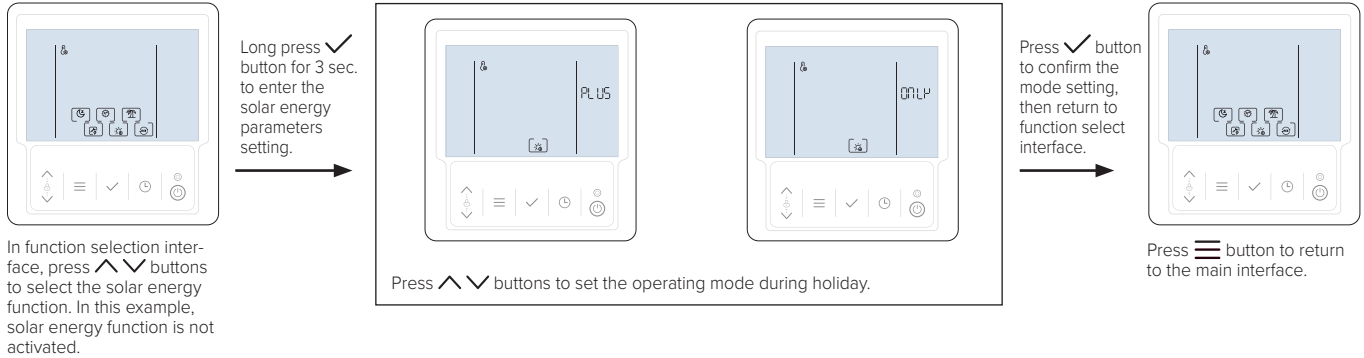

## 5. Hybrid parameter setting

Hybrid parameter is an ambient temperature (code: T4ming) of heat pump operating limit. During setting, the 88:88 will display the ambient temperature (-14~20°C, default 5), and the 88 will display code E4. If the ambient temperature is lower than T4ming, the heat pump will stop operating, and need to operate boiler to continue heating water.

The setting method is as follows:

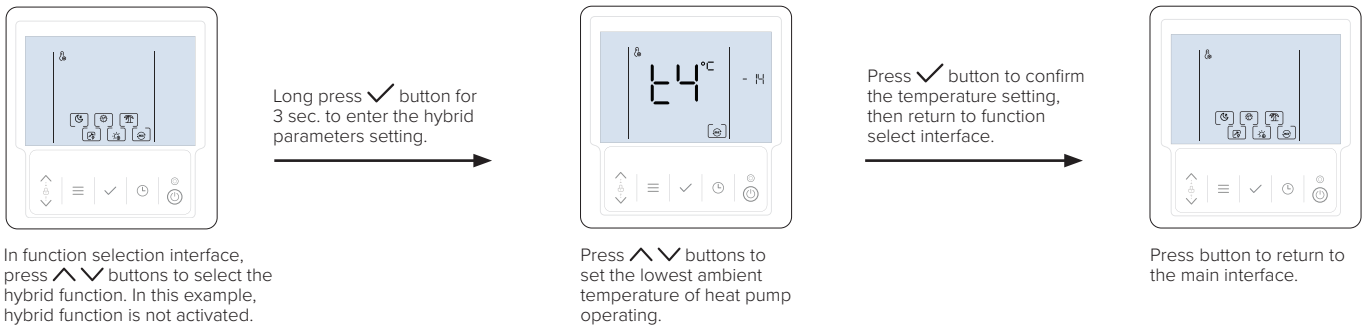

## 6. Silence activation/deactivation

Silence function allows user to set two silence timers. During silence timer, the unit will reduce the operating speeds of compressor and fan motor (depending on silence class) to reduce the operating sound.

The setting method is as follows:

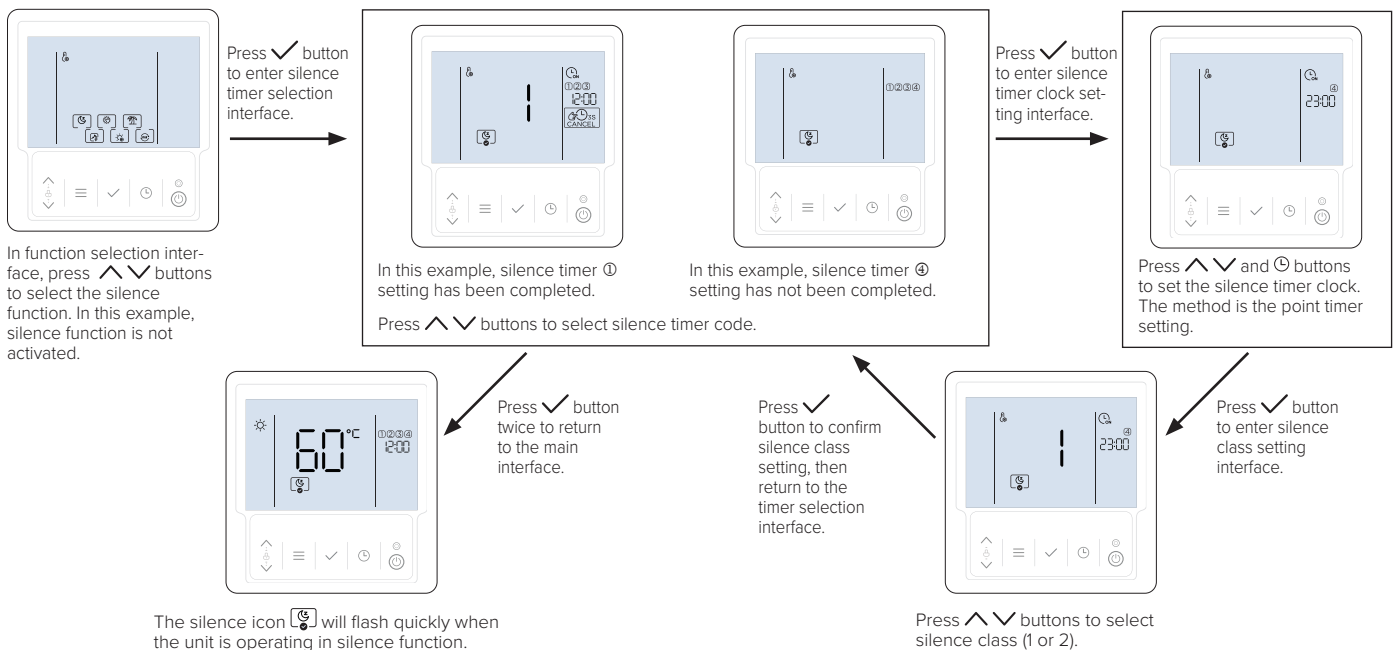

# Operation instructions

## 7. Boost activation/deactivation

Boost function allows user to set two boost timers. During boost timer, the unit will increase the operating speeds of compressor and fan motor to increase the unit capacity. If silence timer meets boost timer, the silence timer is prior.

The setting method is as follows:

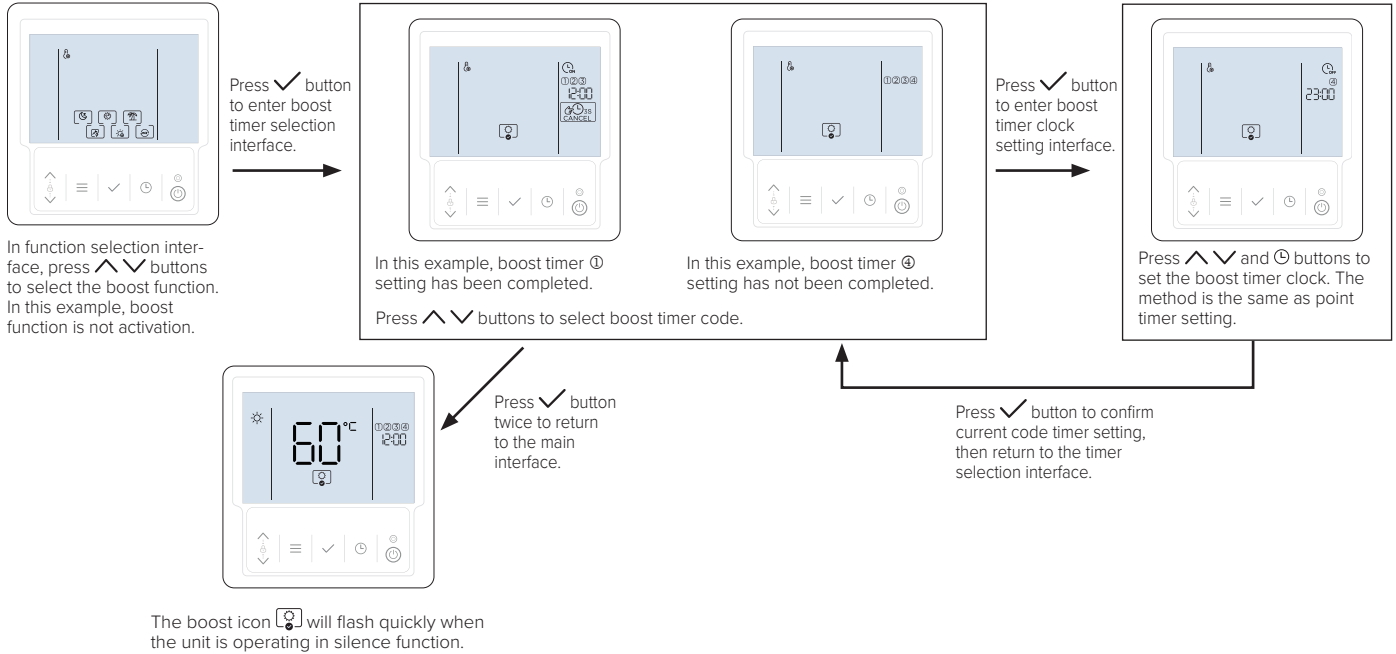

## Manual function

In main interface, long press ✓ button for 3 sec. to enter manual function selection interface, setting icon (⌚) and manual function icons (such as e-heating [🔥], disinfection [🧼], silence [🔇], boost [⚡], depend on the installation settings) will be lightened, then press ^/v buttons to select function. If the function is selected, the function icon will slowly flash. Press ✓ button to activate or deactivate the selected manual function. If the function is activated, the function icon (such as disinfection [🧼]) and the ✓ icon will be lightened together (such as [🧼]). In manual silence function, the silence class is fixed to class 1.

Setting method (such as manual e-heating):

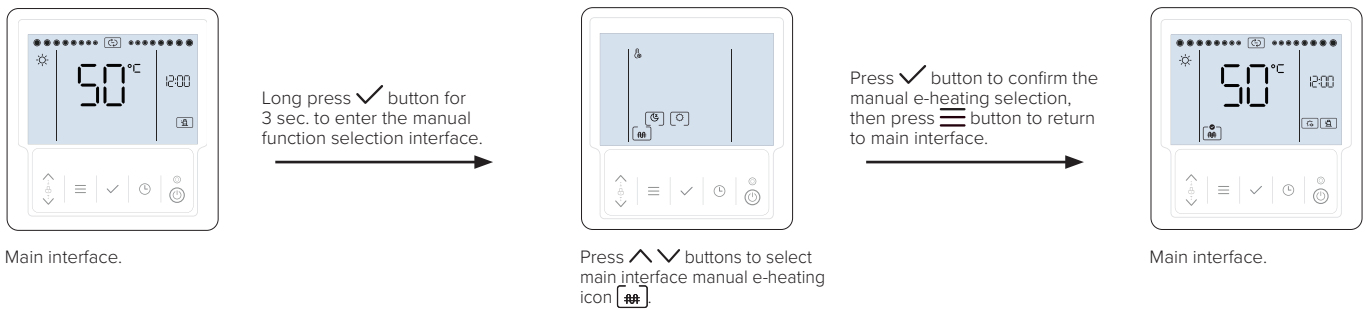

The activated manual function will slowly flash in main interface.

After the manual e-heating function is activated, if the e-heater is off, the manual e-heating function will automatically be deactivated.

After the manual disinfection function is activated, if the water temperature reach the target disinfection temperature, the manual disinfection function will automatically be deactivated.

After the manual boost function is activated, when the compressor of unit stop, then the manual boost function will automatically be deactivated.

# Operation instructions

## Query

Press  $\wedge + \text{Q}$  buttons for 1 sec. to query unit operating parameter. During querying, press  $\wedge \vee$  buttons to switch different parameters. The  $\text{Q}$  icon will be lightened during querying. If some parameters are invalid for some unit, the parameter will be displayed as "--" or "----".



Query explanation:

| DISPLAYED AT 88:88  | EXPLANATION  | DISPLAYED AT 188                                    |
|---|--|---|
| Fan speed value (rpm)   | Fan speed  | FR (FA)   |
| Pulse value   | Pulse value of EXV1                                  | E1 (E1)   |
| Compressor speed (Hz)   | Compressor speed                                     | Fr (Fr)   |
| Current value (A)   | Unit current   | Co (Co)   |
| Current value (A)   | E-heater current                                     | CE (CE)   |
| Power value (W)   | Power input  | PR (PA)   |
| Voltage value (V)   | AC voltage supply                                    | uo (uo)   |
| Voltage value (V)   | DC bus voltage                                       | dC (dC)   |
| Temperature value (°C)  | Discharge temp. of compressor (Tp)                   | tP (Tp)   |
| Temperature value (°C)  | Suction temp. of compressor (Th)                     | tH (Th)   |
| Temperature value (°C)  | Heat exchanger temp. of outdoor unit (T3)            | t3 (T3)   |
| Temperature value (°C)  | Ambient temp. of outdoor unit (T4)                   | t4 (T4)   |
| Temperature value (°C)  | Upper temp. of water tank (T5U)                      | t5 (T5U)  |
| Temperature value (°C)  | Lower temp. of water tank (T5L)                      | t5 (T5L)  |
| Temperature value (°C)  | Ambient temp. limit of E-heater (Td)                 | tD (Td)   |
| t r dh (Trdh)   | Restart offset temp. of unit(Trdh)                   | Temp. value (°C)                                    |
| SG SL (SGSL)  | Smart grid class                                     | Class value<br>(0 means no signal)                  |
| Power value in kWh, don't display ":"   | Cumulative estimated power consumption               | AP (AP)   |
| Power value in kWh. The top two display integer, and the last two display decimal, and ":" means the decimal point. | Estimated power consumption of E-heater in 24 hours  | EP (EP)   |
| Power value in kWh. The top two display integer, and the last two display decimal, and ":" means the decimal point. | Estimated power consumption of heat pump in 24 hours | HP (HP)   |
| Integer time value in hours, don't display ":"  | Cumulative operating time of unit                    | t1 (t1)   |
| Integer time value in hours, don't display ":"  | Cumulative operating time of compressor              | t2 (t2)   |
| Integer time value in hours, don't display ":"  | Cumulative operating time of E-heater                | t3 (t3)   |
| EF (EF)   | Clock chip state                                     | Display code "EF" if chip error, else display "--". |
| Er 1 (Er1)  | Historical fault code                                | Fault code  |
| Er 2 (Er2)  | Historical fault code                                | Fault code  |
| Er 3 (Er3)  | Historical fault code                                | Fault code  |
| Ctrl (Ctrl)   | Software version of controller                       | Version number                                      |
| ODU (ODU)   | Software version of outdoor unit                     | Version number                                      |
| Address (range 1~63)  | Unit address   | Ad (Ad)   |

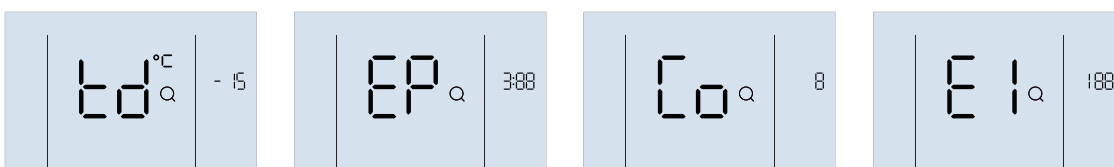
Some interface examples are as follows:



## Error and other codes explanation

When the unit occurred any fault, the error code will be displayed at **88:88**, and alarm icon  will quickly flash, and cancel icon  will slowly flash, and buzzer will sound 3 times every 180 sec. Long press  for 3 sec. to cancel buzzer, but alarm icon and error code will quickly flash until the fault is removed.

### Error and Other Code Explanation

| CODE | EXPLANATION   |
|------|---|
| E0   | There is not enough water in the water tank   |
| E2   | Communication malfunction between controller and main control board   |
| E4   | Water tank temperature sensor error (T5L)   |
| E5   | ODU heat exchanger temperature sensor error (T3)  |
| E6   | ODU ambient temperature sensor error (T4)   |
| E9   | Suction temperature sensor error (Th)   |
| E8   | E0 protection continuously occurs three times   |
| EA   | Discharge temperature sensor error (Tp)   |
| EE   | EEPROM chip error   |
| EF   | Clock chip error  |
| EP   | Leakage error of e-heater   |
| P0   | System low pressure protection (low pressure switch )   |
| P1   | System high pressure protection (high pressure switch )   |
| P3   | Over load protection of inverter compressor   |
| P4   | High discharge temperature (Tp) protection  |
| PA   | Low water temperature protection  |
| bA   | The ambient temperature exceeds the declared range (not an error)   |
| bb   | Low heat pump capacity  |
| C7   | High temperature protection of inverter module  |
| CH   | Over load protection of E-heater ( 16 A)  |
| H1   | Communication malfunction between main control board and inverter board   |
| H4   | Three times L0 protect  |
| H6   | The DC fan motor malfunction  |
| H7   | Voltage protection  |
| HC   | E-heater error (Current is less than 2 A when e - heater operating)   |
| HF   | Inverter module board EEPROM malfunction  |
| HP   | Smart Grid signal error   |
| HH   | 10 times H6 in 2 hours  |
| F1   | DC bus low voltage protection   |
| F2   | Low super-heat of discharge protection  |
| F6   | Electric expansion valve joint fault  |
| L0   | IPM module over current or weak magnetic protection (corresponding to L0x class)  |
| L1   | Module or winding high temperature protection (corresponding to L1x class)  |
| L2   | Bus voltage protection or missing phase (corresponding to L2x class)  |
| L3   | EEPROM 337J Fault Protection (upper and lower bridge), current sampling, PFC sampling bias exception (corresponding to L3x) |
| L4   | Out of step, Zero speed protection and so on  |
| L5   | Phase loss, short circuit to ground, motor winding, inductance and other abnormal protection                                |
| LA   | Phase loss, short circuit to ground, motor winding, inductance and other abnormal protection                                |
| Lb   | PFC protection  |
| d0   | Oil returning (not an error)  |
| d8   | Remote shutdown (not an error)  |
| db   | Anti-freezing operating (not an error) for some unit  |
| dF   | Defrosting (not an error)   |

# Operations

## CAUTION

Cut off the manual switch power when unit fails. Do not restart until problems are solved.

### Characteristics of water heating - 3 minute protection

Restart or open manual switch after the unit has been shut down within a short time. Unit will not start immediately until 3 minutes later, because of the self-protect function of the compressor.

### During operation

If outdoor temperature is higher than normal, the fan motor will run at low air volume or stop running.

### Defrosting function perform at heating operation

- In case of frosting during heating operation, to prevent the heating efficiency from decreasing, defrosting operation will turn on automatically (Approx. 2~7 minutes).

- In the process of defrosting operation, the unit fan motor will stop running.

### Protection device

- When protection device operate, though the unit stops, the operating indicator of wire control still will be blinking.

- When protection device operates, LED indicator will display malfunction code (unit).

- Protection device will act when the following circumstances occur:

a) Air inlet or outlet are blocked.

b) Voltage is a little higher or lower compare to the voltage range (Exceeding the range of -10 %~10 % of 230 V)

### Start the unit after a long period out of service

Start-up the unit after out of service for a long period (includes drive up a unit at the first time), you would see rust mix up water in red, flow out from tap. Such that is a normal phenomenon, please be calmly and keep draining, after for a while rust will disappear.

### Power failure

- In case power failure during the unit working, please stop all operating actions.

- At the next startup after power failure, the RUN indicator of wire controller will blink slowly for several seconds for noting user.

- Mis-operation occur during unit working.

### About RCCB

Outdoor unit must use RCCB, please install an RCCB between in user power supply and the outdoor unit. In case the unit cannot act but not attribute to power failure, please check these RCCB switches at first. Before operate the RCCB, please ensure that the user installing switch is break off.

### Start/stop control

The user can set the target water temperature and dead band temperature on the wired controller. When the upper temperature sensor of the water tank detects that the water temperature is lower than the difference value between the target water temperature and the dead band, the controller will start the heat pump heating until the upper water temperature of the water tank reaches the target water temperature and then stop.

### Energy consumption

If the user sets the water temperature to be lower than the default value (54°C), or sets the dead band to be larger than the default value (5°C), that will cause a decrease in energy consumption of the unit but decrease in hot water supply. If the user sets the dead band to be smaller than the default value (15°C), that will cause an increase in energy consumption of the unit but increase in hot water supply.

### Legionella control method

#### 1 Daily legionella

The set point is locked at 70°C to ensure more than 45% of the water to above 60°C and prevent legionella bacteria growth heat pumps daily.

#### 2 Weekly legionella

The unit will perform disinfection operation weekly (default between 1:00am and 6:00am). During disinfection, the temperature sensor at the bottom of the water tank will be used to control the heat pump operation to heat more than 90% of the water to above 60°C and maintaining it for at least 32 minutes. At this time, the maximum outlet temperature of the water tank will exceed 60°C.

# Installer guide

|  |    |
|--|----|
| <b>Safety precautions</b>                  | 26 |
| <hr/>                                      |    |
| <b>General introduction</b>                |    |
| Outdoor unit                               | 33 |
| Water tank                                 | 33 |
| Specifications                             | 34 |
| <hr/>                                      |    |
| <b>Before installation</b>                 |    |
| Accessories                                | 35 |
| Space                                      | 35 |
| <hr/>                                      |    |
| <b>Installation procedure</b>              |    |
| Dimension and mounting                     | 37 |
| Drain hole position                        | 38 |
| Pipe connection                            | 39 |
| Quick connect couplings                    | 41 |
| <hr/>                                      |    |
| <b>Electrical connection</b>               |    |
| Power supply cords                         | 42 |
| Water tank temperature sensor installation | 43 |
| Outdoor unit and AUX. power connection     | 43 |
| Wiring diagram                             | 44 |
| Dip switch settings                        | 45 |
| <hr/>                                      |    |
| <b>Check</b>                               |    |
| Electric auxiliary heater                  | 46 |
| System parameters check                    | 46 |
| <hr/>                                      |    |
| <b>Service and maintenance</b>             |    |
| General information                        | 47 |
| Confirmation before running                | 49 |
| Troubleshooting                            | 49 |
| Used refrigerant                           | 49 |
| Water quality limitations                  | 49 |
| Maintenance                                | 50 |

**Important notice:** Please read this manual before installing the product and retain for future use. Not following the instructions may result in the product not functioning as intended.

# Safety precautions

Observe safety regulations before starting work and operation.

## DANGER

Indicates a hazard with a high level of risk which, if not avoided, will result in death or serious injury.

## WARNING

Indicates a hazard with a medium level of risk which, if not avoided, could result in death or serious injury.





## CAUTION

Indicates a hazard with a low level of risk which, if not avoided, could result in minor or moderate injury.

## NOTE

Additional information.

### Symbols on the unit

|   |                |  |
|---|----------------|--|
|    | <b>WARNING</b> | Flammable refrigerant is applied. A fire may occur due to unexpected leakage of refrigerant.   |
|  | <b>CAUTION</b> | Read the operation manual carefully before any further action.                                 |
|   | <b>CAUTION</b> | Only a specialist is allowed to take action under the instructions of the installation manual. |
|   | <b>CAUTION</b> | The information is available in the relevant documentation.                                    |

### Target group

## DANGER

These instructions are exclusively intended for qualified contractors and authorized installers.

- Work on the refrigerant circuit with flammable refrigerant in safety group A3 may only be carried out by authorized heating contractors. These heating contractors must be trained in accordance with EN 378 Part 4 or IEC 60335-2-40, Section HH. The certificate of competence from an industry accredited body is required.
- Brazing/soldering work on the refrigerant circuit may only be carried out by personnel certified in accordance with ISO 13585 and AD 2000, Data sheet HP 100R. And only contractors qualified and certified for the processes can perform brazing/soldering work. The work must fall within the range of applications purchased and be carried out in accordance with the prescribed procedures. Soldering/brazing work on accumulator connections requires certification of personnel and processes by a notified body according to the Pressure Equipment Directive (2014/68/EU).
- Work on electrical equipment may only be carried out by a qualified electrician.
- Before initial commissioning, all safety related points must be checked by the particular certified heating contractors. The system must be commissioned by the system installer or a qualified person authorized by the installer.

### Intended use

For continued safety of this appliance it must be installed, operated and maintained in accordance with the manufacturers instructions.

This appliance may deliver water at high temperature. Refer to the Plumbing Code of Australia (PCA), local requirements and installation instructions to determine if additional delivery temperature control is required.

There is a risk of injury or death to the user or others, or of damage to the product and other property in the event of improper or unintended use.

The product is an air-to-water heat pump with monoblock design.

The product uses the outdoor air as a heat source and can be used to heat a residential building and generate domestic hot water.

The air that escapes from the product must be able to flow out freely, and must not be used for any other purposes.

The product is only intended for outdoor installation.

The product is intended exclusively for domestic use, which means that the following places are not appropriate for installation:

- Where there is mist of mineral oil or oil spray or vapors. Plastic parts may deteriorate, and cause joint loose and leakage of water.
- Where corrosive gases (such as sulfurous acid gas) are produced, or corrosion of copper pipes or soldered parts may cause leakage of refrigerant.
- Where there is machinery which emits massive electromagnetic waves. Enormous electromagnetic waves can disturb the control of the system and cause equipment malfunction.
- Where flammable gases may leak, carbon fiber or ignitable dust is suspended in the air or volatile flammables such as paint thinner or gasoline are handled. These types of gases might cause a fire.
- Where the air contains high levels of salt such as a location near the ocean.
- Where voltage fluctuates a lot, such as a location in a factory.
- In vehicles or vessels.
- Where acidic or alkaline vapors are present.

Intended use includes the following:

- Observance of the operating instructions included for the product and any other installation components.
- Compliance with all inspection and maintenance conditions listed in the instructions.
- Installing and setting up the product in accordance with the product and system approval.
- Installation, commissioning, inspection, maintenance and troubleshooting by qualified contractors and authorised installers.

Intended use also covers installation in accordance with the IP code.

This appliance can be used by children aged from 8 years and above and persons with reduced physical, sensory or mental capabilities or lack of experience and knowledge provided that they have been given supervision or instruction concerning the use of the appliance in a safe way and understand the hazards involved. Children should not play with the appliance. Cleaning and maintenance should not be made by children without supervision.

Any other use that is not specified in these instructions, or use beyond that specified in this document, should be considered as improper use. Any direct commercial or industrial use is also deemed to be improper.

## CAUTION

Improper use of any kind is prohibited.

- Do not rinse the unit.
- Do not place any object or equipment on top of the unit (top plate).
- Do not climb, sit or stand on top of the unit.

# Safety precautions

## Regulations to be observed

1. National installation regulations.
2. Statutory regulations for the prevention of accidents.
3. Statutory regulations for environmental protection.
4. Statutory requirements for pressure equipment: Pressure Equipment Directive 2014/68/EU.
5. Codes of practice of the relevant trade associations.
6. Relevant country-specific safety regulations.
7. Applicable regulations and guidelines for operation, service, maintenance, repair and safety of cooling, air conditioning and heat pump systems containing flammable and explosive refrigerant.

## Safety instructions for working on the system

The outdoor unit contains flammable refrigerant R290 (propane C3H8). In case of a leak, the escaping refrigerant may form a flammable or explosive atmosphere in the ambient air. A safety zone is defined in the immediate vicinity of the outdoor unit, in which special rules apply when work is performed on the appliance. See section "Safety zone".

## Working in the safety zone

### DANGER

Risk of explosion: Refrigerant leak may form a flammable or explosive atmosphere in the ambient air.

Take the following measures to prevent fire and explosion in the safety zone:

- Keep ignition sources away, including naked flames, plug sockets, hot surfaces, light switches, lamps, electrical devices not free of ignition sources, mobile devices with integrated batteries (such as mobile phones and fitness watches).
- Do not use any sprays or other combustible gases in the safety zone.

### CAUTION

Permissible tools: All tools for working in the safety zone must be designed and explosion-protected in accordance with the applicable standards and regulations for refrigerant in safety groups A2L and A3, such as brushless machines (cordless disposal containers, installation aids, and screwdrivers), extraction equipment, vacuum pumps, conductive hoses, and mechanical tools of non-sparking material.

### CAUTION

The tools must also be suitable for the pressure ranges in use. Tools must be in perfect maintenance conditions.

- The electrical equipment must meet the requirements for areas at risk of explosion, zone 2.
- Do not use flammable materials such as sprays or other flammable gases.
- Before starting work, discharge static electricity by touching earthed objects, such as heating or water pipes.
- Do not remove, block or bridge safety equipment.
- Do not make any changes: Do not modify the outdoor unit, inlet/outlet lines, electrical connections/cables or the surroundings. Do not remove any components or seals.

## Working on the system

Switch off the power supply for the unit (including all affiliated parts) at a separate fuse or mains isolator.

Check and ensure that the system is no longer live.

### CAUTION

In addition to the control circuit there may be several power circuits.

### DANGER

Contact with live components can result in severe injuries. Some components on PCBs remain live even after the power supply has been switched off. Prior to removing covers from the appliances, wait at least 4 minutes until the voltage has completely dropped out.

- Safeguard the system against reconnection.
- Wear suitable personal protective equipment when carrying out any work.
- Do not touch any switch or electrical parts with wet fingers. It may cause electrical shock and compromise the system.

### DANGER

Hot surfaces and fluids can result in burns or scalding. Cold surfaces may cause frostbite.

- Prior to servicing or maintenance tasks, switch off and allow the equipment to cool down or warm up.
- Do not touch hot or cold surfaces on the appliance, fittings or pipework.

### NOTE

Electronic assemblies can be damaged by electrostatic discharge. Before beginning work, touch earthed objects, such as heating or water pipes, to discharge any static.

### CAUTION

When working on systems using flammable refrigerants, the technician should consider certain locations as "temporary flammable zones". These are normally regions where at least some emission of refrigerant is anticipated to occur during the normal working procedures, such as recovery, charging and evacuation, typically where hoses may be connected or disconnected. The technician should ensure three meters safety working area (radius of the unit) in case of any accidental release of refrigerant that forms a flammable mixture with air.

# Safety precautions

## Working on the refrigerant circuit

R290 refrigerant (propane) is an air displacing, colorless, flammable, odorless gas which forms explosive mixtures with air. Refrigerant drained must be properly disposed of by authorised contractors.

Perform the following measures before beginning work on the refrigerant circuit:

- Check the refrigerant circuit for leaks.
- Ensure very good ventilation especially in the floor area and maintain this for the duration of the work.
- Secure the area surrounding the work area.
- Inform the following persons of the type of work to be carried out:
  - All maintenance personnel
  - All persons in the vicinity of the system.
- Inspect the area immediately around the heat pump for flammable materials and ignition sources:  
Remove all flammable materials and ignition sources.
- Before, during and after the work, check the surrounding area for escaping refrigerant using an explosion-proof refrigerant detector suitable for R290. This refrigerant detector must not generate any sparks and must be suitably sealed.
- A CO<sub>2</sub> or powder extinguisher must be available in the following cases:
  - Refrigerant is being drained.
  - Refrigerant is being topped up.
  - Soldering or welding work is in progress.
- Display signs prohibiting smoking.

### DANGER

Escaping refrigerant can lead to fires and explosions that result in very serious injuries or death.

- Do not drill or apply heat to a refrigerant circuit filled with refrigerant.
- Do not operate Schrader valves unless a fill valve or extraction equipment is attached.
- Take measures to prevent electrostatic charge.
- Do not smoke. Avoid naked flames and sparks. Never switch lights or electrical appliances on or off in environments with naked flames or sparks.
- Components that contain or contained refrigerant must be labeled, and stored in well ventilated areas in accordance with the applicable regulations and standards.

### DANGER

Direct contact with liquid or gaseous refrigerant can cause serious damage to health such as frostbite and/or burns. There is a risk of asphyxiation if liquid or gaseous refrigerant is breathed in.

- Prevent direct contact with liquid or gaseous refrigerant.
- Wear personal protective equipment when handling liquid or gaseous refrigerant.
- Never breathe in any refrigerant vapor.

### DANGER

Refrigerant is under pressure: Mechanical loading of lines and components can cause leaks in the refrigerant circuit. Do not apply loads to the lines or components, such as supporting or placing tools.

### DANGER

Hot or cold metallic surfaces of the refrigerant circuit may cause burns or frostbite in case of skin contact. Wear personal protective equipment to protect against burns or frostbite.

### NOTE

Hydraulic components may freeze during refrigerant removal. Drain heating water from the heat pump beforehand.

### DANGER

Damage to the refrigerant circuit can cause refrigerant to enter the hydraulic system. After completion of the work, vent the hydraulic system correctly. When doing so, ensure the area is sufficiently ventilated.

## Installation general

- Be sure to use only specified accessories and parts for installation. Failure to use specified parts may result in water leakage, electric shocks, fires, or the unit falling from its mount.
- Install the unit on a foundation that can withstand its weight. Insufficient physical strength may cause the unit to fall and possible injury.
- Perform specified installation work with full consideration of strong wind, hurricanes, or earthquakes. Improper installation may result in accidents due to equipment falling.
- Earth the unit and install a ground fault circuit interrupter in accordance with local regulations. Operating the unit without a proper ground fault circuit interrupter may cause electric shocks and fires.
- Install the power cable at least 3 feet (1 meter) away from televisions or radios to prevent interference or noise. (Depending on the radio waves, a distance of 3 feet (1 meter) may not be sufficient to eliminate the noise.)
- Any damaged power cord must be replaced by the manufacturer or its service agent or a similarly qualified person in order to avoid a hazard.

### CAUTION

Do not install any air vent valve in the indoor side. Make sure the outlet of the indoor safety valve leads to the outdoor side.

No ignition sources exist around the air vent valve and the outlet of safety valve.

Two situations should be considered for outdoor installations to prevent damage to the system, releases, and undesirable consequences:

- Where the equipment is located in an area accessible by members of the public, and.
- Where the equipment is located in a restricted area, with access to authorised persons only.



### DANGER

Open flames, fires, open ignition sources and smoking are prohibited.



### DANGER

Inflammable matters are prohibited.

# Safety precautions

## Freezing protection

### CAUTION

Freezing can cause damage to the heat pump.

- Thermally insulate all the hydraulic lines.
- Antifreeze can be filled in the secondary circuit in accordance with local regulations and standards.

## Connecting cables

### DANGER

With short electrical cables, should there be leakage in the refrigerant circuit, gaseous refrigerant may reach the inside of the building. Min. length of the electrical connecting cables between the indoor and the outdoor unit: 3 m.

## Repair work

### CAUTION

Repairing components that fulfill a safety function can compromise the safe operation of the system.

- Replace faulty components only with genuine spare parts from the manufacturer.
- Do not undertake any repairs on the inverter. Replace the inverter if there is a defect.
- Repair work should not be performed in the field. Repair the unit in a specified location.

## Auxiliary components, spare and wearing parts

### DANGER

Spare and wearing parts that have not been tested together with the system can compromise the function of the system.

Installing non-authorized components and making non-approved modifications or conversions can compromise the safety and may invalidate our warranty. Only use original spare parts supplied or approved by the manufacturer for replacement.

## Safety instructions for operating the system

### What to do if refrigerant leaks

### WARNING

To avoid potential risk from refrigerant leak, always keep 2 meters away from the unit, especially for kids, no matter the unit is in operation or not.

### DANGER

Refrigerant leak can lead to fires and explosions that result in very serious injuries or death. Breathing in refrigerant may cause asphyxiation.

- Ensure very good ventilation especially in the floor area of the outdoor unit.
- Do not smoke. Avoid naked flames and sparks. Never switch lights or electrical appliances on or off in environments with naked flames or sparks.
- Evacuate any people from the dangerous zone.
- From a safe position, switch off the power supply for all system components.
- Remove ignition sources from the dangerous zone.
- The system user should know that no ignition source may be brought into the dangerous zone during the repair.
- Repair work must be carried out by an authorized contractor.
- Do not recommission the system until it is repaired.

### CAUTION

Direct contact with liquid or gaseous refrigerant can cause serious damage to health, e.g. frostbite and/or burns. Breathing in liquid or gaseous refrigerant may cause asphyxiation.

- Prevent direct contact with liquid or gaseous refrigerant.
- Never breathe in refrigerant vapors.

### What to do if water leaks

### DANGER

If water leaks from the appliance, an electric shock may occur. Switch off the heating system at the external isolator (e.g. fuse box, domestic distribution board).

### DANGER

If water leaks from the appliance, scalding may occur. Never touch hot water.

### What to do if the outdoor unit ices up

### CAUTION

A build-up of ice in the condensate pan and in the fan area of the outdoor unit can cause damage to the equipment.

- Do not use mechanical items/aids to remove ice.
- Before using electrical heating appliances, check the refrigerant circuit for leaks with a suitable measuring device. The heating appliance should not be a source of ignition, and must meet the requirements of EN 60335-2-30.
- If ice regularly builds up on the outdoor unit (e.g. in areas where frost and heavy fog occur frequently), install a fan ring heater that is suitable for refrigerant R290 and/or an electric ribbon heater in the condensate pan.

# Safety precautions

## Safety instructions for storage of the outdoor unit

The outdoor unit is charged at the factory with refrigerant R290 (propane).

### DANGER

Refrigerant leak can lead to fires and explosions that result in very serious injuries or death. Breathing in refrigerant may cause asphyxiation. Store the outdoor unit in the following conditions:

- An explosion prevention plan must be in place for storage.
- Ensure the storage location is well ventilated.
- Keep away from ignition sources (avoid exposure to heat and smoking).
- Temperature range for storage:  $-25\text{ }^{\circ}\text{C}$  to  $70\text{ }^{\circ}\text{C}$
- Only store the outdoor unit in its ex factory protective packaging.
- Protect the outdoor unit against damage.
- The maximum number of outdoor units that may be stored in one place is determined according to local conditions.

### CAUTION

A fire with R290 should only be fought with CO<sub>2</sub> or dry powder extinguishers.

## About the refrigerant

### WARNING

- The following applies to R290 refrigerant systems.
- Prior to work on systems containing flammable refrigerants, safety checks are necessary to minimize the risk of ignition.

For repair of the refrigerating system, the following precautions should be complied with prior to conducting work on the system.

Work should be undertaken under a controlled procedure so as to minimize the risk of a flammable gas or vapor being present while the work is being performed.

All maintenance staff and others working in the local area should be instructed on the nature of work being carried out. Work in confined spaces should be avoided. The area around the workspace should be sectioned off. Ensure that the area is safe through control of flammable materials.

The area should be checked with an appropriate refrigerant detector prior to and during work, to ensure the technician is aware of potentially flammable atmospheres.

Ensure that the leak detection equipment being used is suitable for use with flammable refrigerants, i.e. the equipment should be non-sparking, adequately sealed or intrinsically safe. If any hot work is to be conducted on the refrigeration equipment or any associated parts, appropriate fire extinguishing equipment should be available to hand. Have a dry powder or CO<sub>2</sub> fire extinguisher adjacent to the charging area.

No person carrying out work in relation to a refrigeration system which may expose any pipe that contains or has contained flammable refrigerant should use any sources of ignition in such a manner that it may lead to the risk of fires or explosions.

All possible ignition sources, including lighted cigarettes, should be kept sufficiently far away from the site of installation, repair, removal and disposal, during which flammable refrigerant can possibly be released into the surrounding space.

Prior to work, the area around the equipment should be checked to make sure that there are no flammable hazards or ignition risks. "No Smoking" signs should be displayed.

Ensure that the area is in the open or adequately ventilated before breaking into the system or conducting any hot work. A degree of ventilation should continue during the work. The ventilation should safely disperse any released refrigerant and preferably expel it externally into the atmosphere.

For any change of the electrical components, they should be fit for the intended purpose and comply with the correct specifications.

Always follow the manufacturer's maintenance and service guidelines. In case of any doubt, consult the manufacturer's technical department for assistance.

The following checks should be applied to installations using flammable refrigerants:

- The charge size should depend on the size of the room within which refrigerant containing components are installed;
- The ventilation machinery and outlets should operate adequately and not be obstructed;
- If an indirect refrigerating circuit is used, the secondary circuit should be checked for any refrigerant;
- Marking to the equipment should remain visible and legible. Illegible markings and signs should be corrected;
- Refrigeration pipes or components should be installed in positions where they are unlikely to be exposed to any substance which may corrode refrigerant containing components, unless the components are constructed of materials that are inherently resistant to corrosion or are suitably protected against corrosion.

Repair and maintenance of electrical components should include initial safety checks and component inspection procedures.

In the event of a fault that could compromise safety, no power supply should be connected to the circuit until it is satisfactorily dealt with. If the fault cannot be corrected immediately but it is necessary to continue operation, an adequate temporary solution should be used. This should be reported to the owner of the equipment to give advises to all parties involved.

Initial safety checks should include the following:

- Capacitors should be discharged in a safe manner to avoid possibility of sparking;
- No live electrical components and wiring should be exposed while charging, recovering or purging the system;
- The earth bonding should be continuous. During repairs of sealed components, all power supplies should be disconnected from the equipment where work is in progress prior to any removal of sealed covers or other components. If it is absolutely necessary to keep a power supply connected with the equipment during servicing, a permanent leak detection should be performed at the most critical point to avoid a potential hazard.

Particular attention should be paid to the following to ensure that the casing is not altered in such a way that the level of protection is affected by working on electrical components. This includes damage to cables, an excessive number of connections, terminals not compliance with original specifications, damage to seals, and incorrect fitting of glands.

Ensure that seals or sealing materials have not degraded in such a manner that they no longer serve for the purpose of preventing the ingress of flammable atmospheres. Parts for replacement should be in accordance with the manufacturer's specifications.

Do not apply any permanent inductive or capacitance loads that exceed the permissible voltage or current of the equipment in use to the circuit.

Intrinsically safe components are the only types that can be worked on while live in the presence of a flammable atmosphere. The test apparatus should be provided with the correct rating.

Replace components only with parts specified by the manufacturer. Other parts may result in the ignition of refrigerant in the atmosphere due to a leak.

# Safety precautions

Check and ensure that cabling is free from wear, corrosion, excessive pressure, vibration, sharp edges or any other adverse environmental effects. The check should also take into account the effects of aging or continual vibration from sources such as compressors or fans.

When breaking into the refrigerant circuit for repair – or for any other purpose – follow the conventional procedures. However, it is important to follow the best practice.

Since flammability is a consideration, the following procedure should be adhered to:

- Remove the refrigerant;
- Purge the circuit with inert gas;
- Evacuate;
- Purge the circuit again with inert gas;
- Open the circuit by cutting or brazing.

The refrigerant should be recovered into correct recovery cylinders. The system should be “flushed” with OFN to guarantee the unit safety. This process may need to be repeated several times. Compressed air or oxygen should not be used for this task.

Flushing should be achieved by breaking the vacuum in the system with OFN and continuing to fill until the working pressure is achieved before venting to the atmosphere and pulling down to a vacuum. This process should be repeated until no refrigerant exists in the system. When the final OFN charge is used, the system should be vented down to the atmospheric pressure so that the work can start.

This operation is absolutely vital if brazing operations on the pipe-work are to take place. Ensure that the outlet for the vacuum pump is not close to any ignition sources and adequate ventilation is available.

Ensure that contamination of different refrigerants does not occur when using charging equipment. Hoses or lines should be as short as possible to minimize the amount of refrigerant contained in them. Prior to recharging the system, it should be pressure tested with OFN.

## DD.12 Decommissioning:

Before this procedure starts, it is necessary for the technician to be completely familiar with the equipment and all its details. It is recommended that all refrigerants be recovered safely. Prior to the task, an oil and refrigerant sample should be taken in case analysis is required prior to re-use of reclaimed refrigerant. It is essential that electrical power is available before the task is commenced.

- a) Be familiar with the equipment and its operation.
- b) Isolate the system electrically.
- c) Before attempting the procedure, ensure that:
  - Mechanical handling equipment is available, if required, for handling refrigerant cylinders;
  - All personal protective equipment is available and being used correctly; The recovery process is supervised at all times by a competent person;
  - The recovery equipment and cylinders should conform to the appropriate standards.
- d) Pump down refrigerant system, if possible.
- e) If a vacuum is not possible, make a manifold so that refrigerant can be removed from various parts of the system.
- f) Make sure that the cylinders are situated on the scales before recovery.
- g) Start the recovery machine and operate it in accordance with manufacturer's instructions.
- h) Do not overfill the cylinders. (No more than 80 % of volume for liquid charge).
- i) Do not exceed the maximum working pressure of the cylinders, even temporarily.
- j) When the cylinders have been filled correctly, make sure that the cylinders and the equipment are removed from the site promptly and all isolation valves on the equipment are closed off.
- k) Recovered refrigerant should not be charged into another refrigeration system unless it has been cleaned and checked.

Equipment should be labeled stating that it has been de-commissioned and emptied of refrigerant. The label should be dated and signed. Ensure that the equipment is provided with a label stating the existence of flammable refrigerant in the equipment.

When removing refrigerant from a system, either for servicing or decommissioning, it is recommended that all refrigerants be removed safely. Always transfer refrigerant into appropriate cylinders. Ensure that a correct number of cylinders are available for supporting the total system charge. All cylinders to be used should be designated for the recovered refrigerant and labeled for that refrigerant (i.e. special cylinders for the recovery of refrigerant). The cylinders should be complete with pressure relief valves and associated shut-off valves in good working conditions. Empty recovery cylinders should be evacuated and, if possible, cooled down before recovery occurs.

The recovery equipment should be in good working conditions with a set of instructions concerning the equipment that is at hand and should be suitable for the recovery of flammable refrigerants. In addition, a set of calibrated weighing scales should be available and work properly. Hoses should be complete with leak-free disconnect couplings and work properly. Before using the recovery machine, check and ensure that it is in satisfactory working conditions and has been properly maintained, and that all associated electrical components are sealed to prevent ignition in the event of a refrigerant leak. Consult the manufacturer if in case of any doubt.

The recovered refrigerant should be returned to the refrigerant supplier in correct recovery cylinders, with the relevant Waste Transfer Note arranged. Do not mix refrigerants in recovery units and especially not in cylinders. If any compressor or compressor oils is to be removed, ensure that it has been evacuated to an acceptable level to ensure that flammable refrigerant does not remain within the lubricant. The evacuation process should be carried out prior to returning the compressor to the supplier. To accelerate this process, you can only heat the compressor body with an electric heater. Draining oil from the system should ensure the safety.

**Warning:** Disconnect the appliance from its power source during servicing and parts replacement.

These units are partial unit air conditioners, complying with partial unit requirements of this International Standard, and must only be connected to other units that have been confirmed as complying to corresponding partial unit requirements of this International Standard.

## Leak detection

Under no circumstances shall potential sources of ignition be used in the searching for or detection of refrigerant leaks. A halide torch (or any other detector using a naked flame) shall not be used.

The following leak detection methods are deemed acceptable for systems containing flammable refrigerants. Electronic leak detectors should be used to detect flammable refrigerants, but the sensitivity may not be adequate, or may need re-calibration. (Detection equipment should be calibrated in a refrigerant-free area.) Ensure that the detector is not a potential source of ignition and is suitable for the refrigerant. Leak detection equipment should be set at a percentage of the LFL of the refrigerant and should be calibrated to be suitable for the refrigerant employed, with the appropriate percentage of gas (25% maximum) confirmed. Leak detection fluids should be suitable for most refrigerants but the use of detergents containing chlorine should be avoided as the chlorine may react with the refrigerant and corrode the copper pipes. If a leak is suspected, all naked flames should be removed or extinguished. If a leakage of refrigerant is found and brazing is required, all of the refrigerant should be recovered from the system, or isolated (by means of shut off valves) in a part of the system that is far from the leak. The system should be purged with oxygen free nitrogen (OFN) both before and during the brazing process.

# Safety precautions

## Disposal

This equipment uses flammable refrigerants.

The disposal of the equipment must comply with national regulations.

Do not dispose this product as unsorted municipal waste. Collection of such waste separately for special treatment is necessary.

- Do not dispose of electrical appliances as unsorted municipal waste, and use separate collection facilities.
- Contact your local government for information regarding the collection systems available.

If electrical appliances are disposed of in landfills or dumps, hazardous substances can leak into the groundwater and get into the food chain, damaging your health and well-being.



**WARNING: Risk of fire**

# General introduction

## Outdoor unit

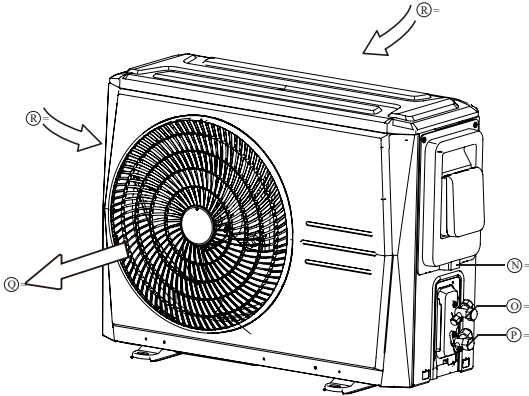

| NO. | DESCRIPTION              |
|-----|--------------------------|
| 1   | Power cord enter         |
| 2   | Refrigerant gas valve    |
| 3   | Refrigerant liquid valve |
| 4   | Air outlet               |
| 5   | Air inlet                |

## Water tank

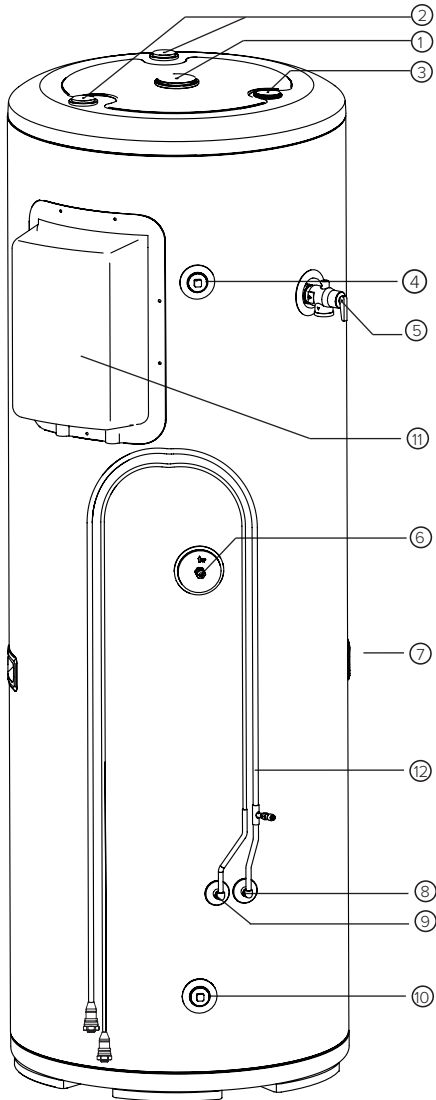

| NO. | DESCRIPTION                       |
|-----|-----------------------------------|
| 1   | Magnesium rod insertion port      |
| 2   | Foam filling port                 |
| 3   | Reserved port                     |
| 4   | Water outlet                      |
| 5   | Pressure temperature relief valve |
| 6   | Water tank temperature sensor     |
| 7   | Handle                            |
| 8   | Refrigerant gas pipe              |
| 9   | Refrigerant liquid pipe           |
| 10  | Water inlet/Drain outlet          |
| 11  | Electric auxiliary heater         |
| 12  | Quick connection tube             |

# General introduction

## Specifications

|                 |                              |                              |                   |  |
|-----------------|------------------------------|------------------------------|-------------------|--|
|                 | Model number                 |                              | HPRX300E-1        |  |
|                 | Ambient temperature          |                              | °C                | -15~46   |
|                 | Leaving water temperature    |                              | °C                | 52~70 (default 70°C)                               |
|                 | Heating                      | Capacity <sup>1</sup>        | W                 | 3600   |
|                 |                              | Input                        | W                 | 1800   |
|                 | Hot water yield              |                              | m <sup>3</sup> /h | 0.04721/ 0.06022                                   |
|                 | Refrigerant piping           | Liquid side                  | mm/inch           | φ 6.35 / φ 1/4'                                    |
|                 |                              | Gas side                     | mm/inch           | φ 9.52 / φ 3/8'                                    |
|                 |                              | Max. height difference       | m                 | 10   |
|                 |                              | Max. refrigerant pipe length | m                 | 20   |
| Design pressure |                              | MPa                          | 3.3               |  |
| Outdoor Unit    | Outdoor unit power supply    |                              | V/N/Hz            | 220-240/1/50                                       |
|                 | Max. current                 |                              | A                 | 26.0   |
|                 | Compressor Type              |                              | Type              | DC inverter rotary                                 |
|                 | Fan                          | Type                         | DC inverter       |  |
|                 | Air side heat exchanger      |                              | Type              | Hydraulic aluminum fin + Inner grooved copper tube |
|                 | Throttle                     |                              | Type              | Electric expansion valve                           |
|                 | Outdoor sound pressure level |                              | dB(A)             | 54   |
|                 | Dimension                    | Unit dimension (L*W*H)       | mm                | 804*327*555  |
|                 |                              | Packing dimension (L*W*H)    | mm                | 845*390*630  |
|                 |                              | Net weight                   | kg                | 27   |
| Refrigerant     | Type                         | R290                         |                   |  |
|                 | Charged volume               | g                            | 470               |  |
| Water Tank      | Tank volume                  |                              | L                 | 300  |
|                 | Electric heater              | Capacity                     | kW                | 4.2  |
|                 |                              | Power supply                 | V/N/Hz            | 220-240V/1/50                                      |
|                 | Dimension                    | Unit dimension (Ø*H)         | mm                | 580*580*1735                                       |
|                 |                              | Packing dimension (W*D*H)    | mm                | 1835*690*670                                       |
|                 |                              | Net weight                   | kg                | 106  |





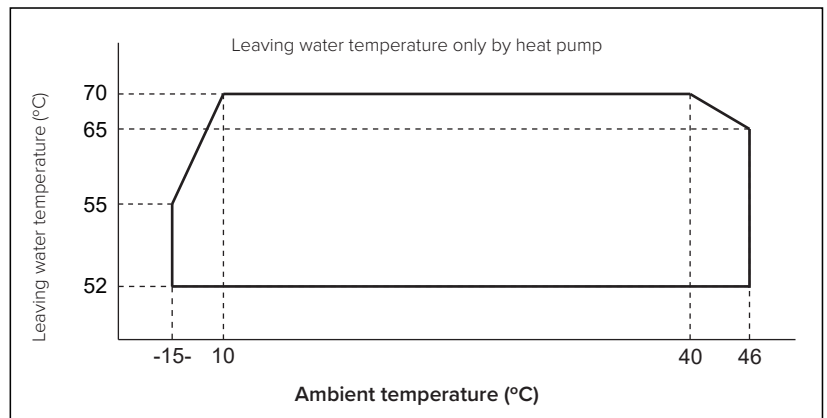



1. Ambient temperature 19/15°C(DB/WB), initial water temperature 9°C, terminative water temp. 60°C.
2. All settings and set points that can be manually adjusted will reset to default settings at mid night 00:00

- 2 The heap pump mode set point will be locked at 70°C.
- 3 All of these modes are one-shot functions and will return to standard mode once complete or will reset to default settings at mid night 00:00.



# Before installation

## Accessories

| Accessory name |                         | Qty | Image  | Purpose   |
|----------------|-------------------------|-----|--|---|
| Outdoor unit   | Installation manual     | 1   |   | Outdoor unit and water tank instruction                       |
|                | Safety manual           | 1   |   | Safety instructions   |
|                | Drain pipe joint        | 1   |   | For condensate water draining                                 |
|                | Water drainage pipe     | 1   |   | Condensate water drainage of unit bottom plate                |
|                | Seal ring               | 1   |   | Seal between water drainage connection and external machine   |
|                | Polypropylene strap     | 1   |   | Wrap the refrigerant tube between outdoor unit and water tank |
| Water tank     | Water tank fixing strip | 1   |   | Fixed water tank  |
|                | Connector               | 2   |   | Connect water tank and safe care                              |
|                | Seal ring               | 2   |  | Prevent rust between water tank and joint                     |

## Space

### NOTE

During installing, it is necessary to reserve enough installation space and maintenance space according to the following figures. Do not install the outdoor unit and tank in a enclosed space.

### Outdoor unit installation and maintenance space (unit: mm)

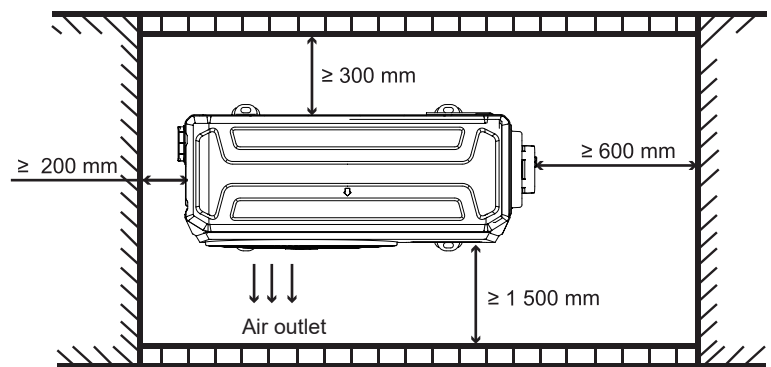
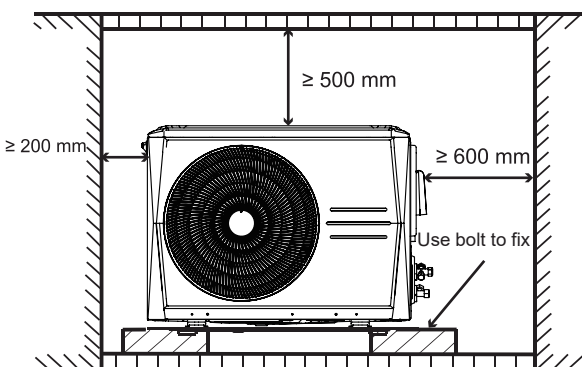

## Before installation

### Water tank installation and maintenance space (unit: mm)

#### NOTE

- If the water tank is completely installed outdoors, it is strongly recommended to install a rain shelter.
- When the water tank is installed outdoors, the distance between the water tank and the fence is not less than 200mm.
- When the water tank is installed indoors, the distance between the water tank and the wall is not less than 600mm.
- For the water tank with electric auxiliary heater, the electric auxiliary heater shall be at least 1 000mm away from the wall to ensure that there is enough space for electric auxiliary heat maintenance

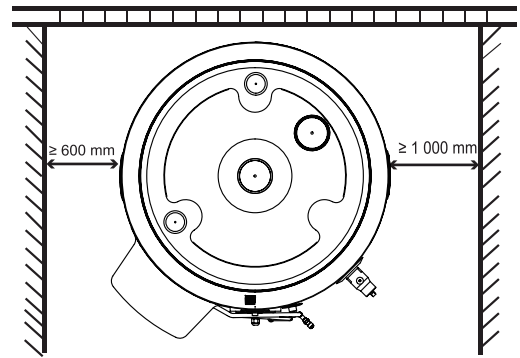
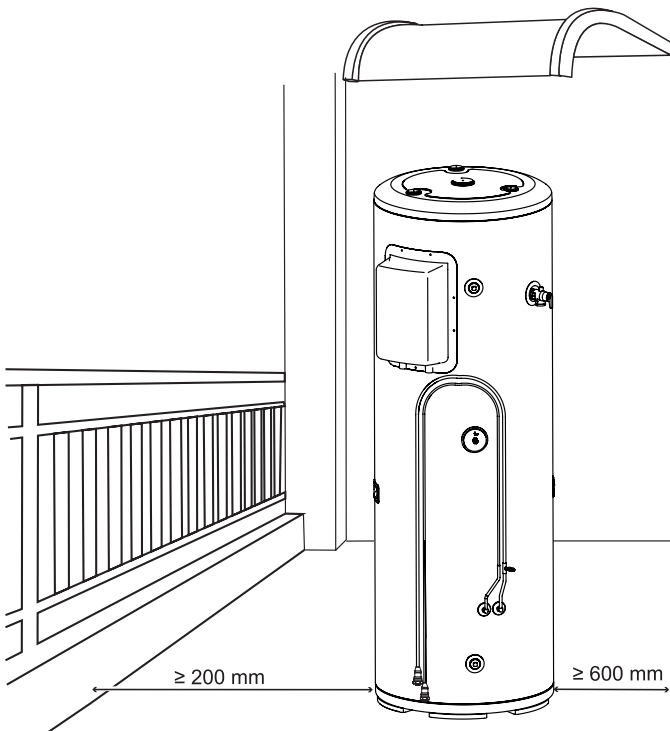

The Aux\* is replaceable material, need to make sure there is enough space for e-heater maintenance.

\*Electric auxiliary heater is shortened to Aux.

# Installation

## NOTE

- Ask your dealer or specialized person for moving, repair, and maintenance.
- Install it in the place without direct sunlight and other direct heat radiations. If it can't be avoided, please add a cover to prevent unit from direct sunlight.
- The ceiling is horizontal, and its structure can endure the weight of the indoor unit.
- Please firmly install the unit, otherwise it may cause abnormal noise and vibration.
- Remove obstacles nearby, a narrow circulation space may influence performance of the unit.
- Install in the place that closes to water tank as far as possible, under the condition that the installation requirements could be satisfied.
- When installing in the place that near to the sea and high place where strong wind blows, install the unit against a wall or use a baffle when necessary to ensure the unit could run normally. Especially in the place with strong wind, pay attention not to let strong wind blow back to the unit.
- If install the unit in a basement, inside the room or other confined space, please pay attention to air discharge and air supply circulation around the unit and outside. Circulation air volume should not less than 1250m<sup>3</sup>/h.

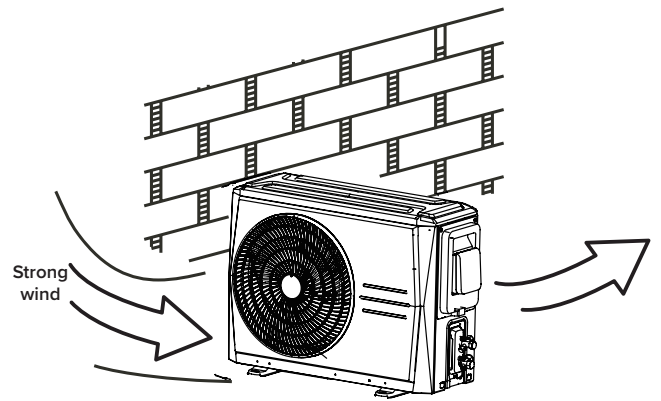
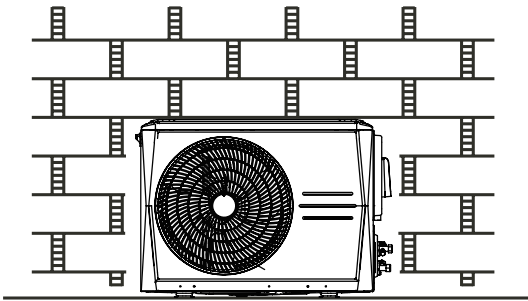

## Dimension and mounting

### Outdoor unit

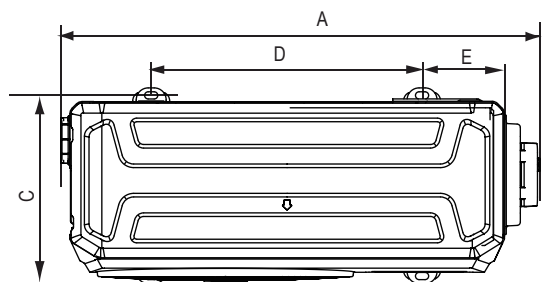
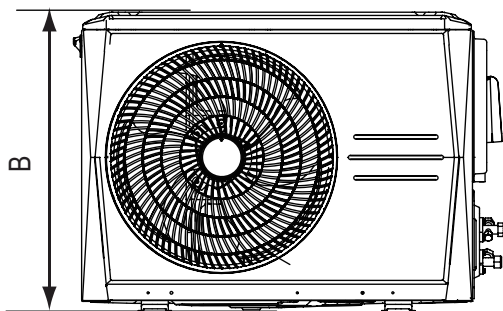

Fix the four bases of the outdoor unit on flat ground with bolts.

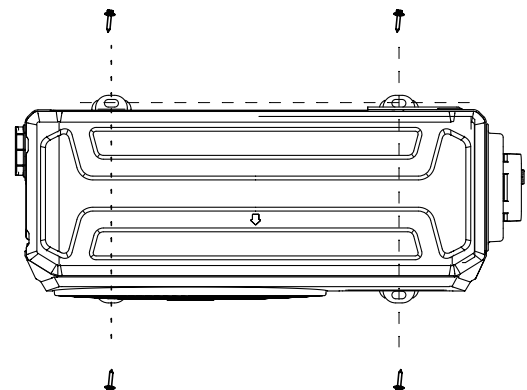

| Dimension and mounting dimension |     |     |     |     |
|----------------------------------|-----|-----|-----|-----|
| A                                | B   | C   | D   | E   |
| 804                              | 555 | 302 | 452 | 137 |

# Installation

## Water tank

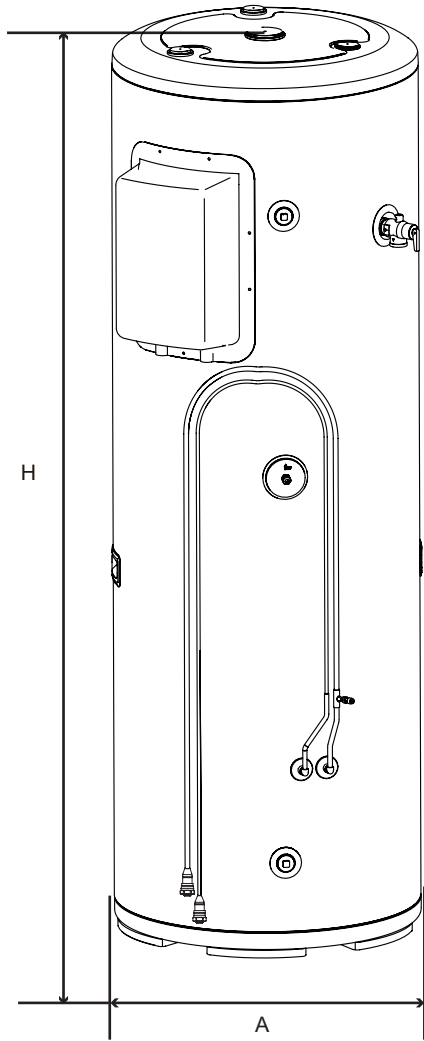

| Dimension | A   | H    |
|-----------|-----|------|
| Model     |     |      |
| 200L      | 505 | 1665 |
| 300L      | 280 | 1735 |

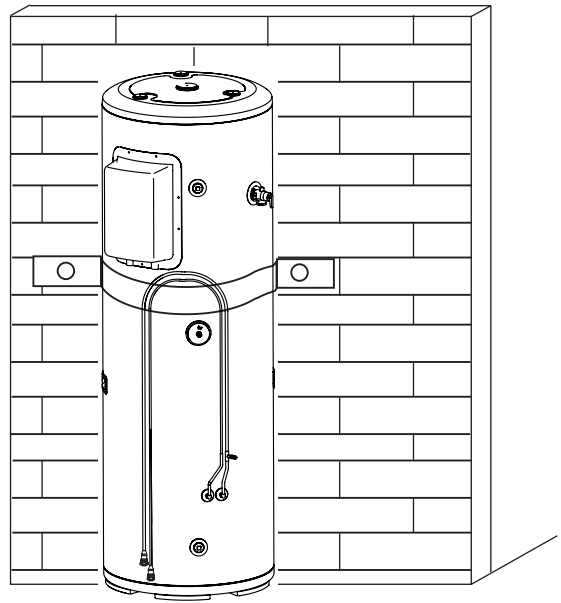

Securely attach the water tank using the fixing strip as illustrated to ensure stability.

## Drain hole position

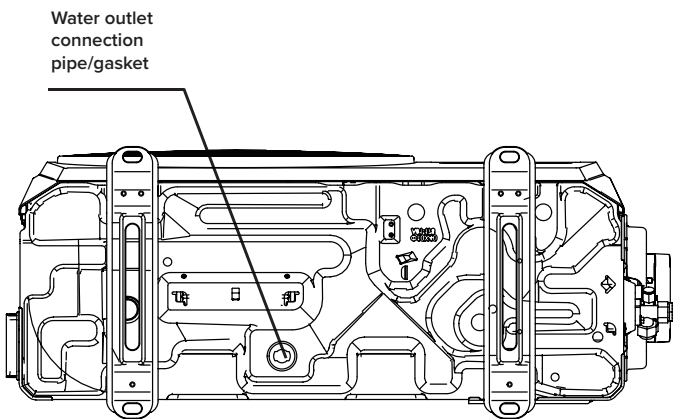

Use the Allen key to open the drain valve and release the water. If no water flows out, the draining process is complete.

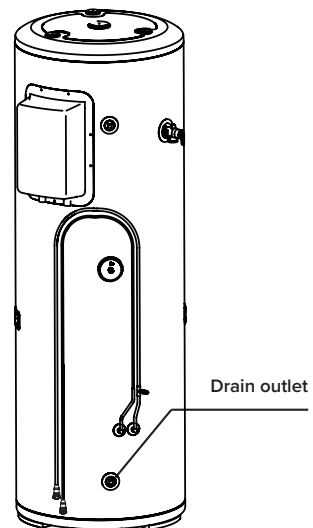







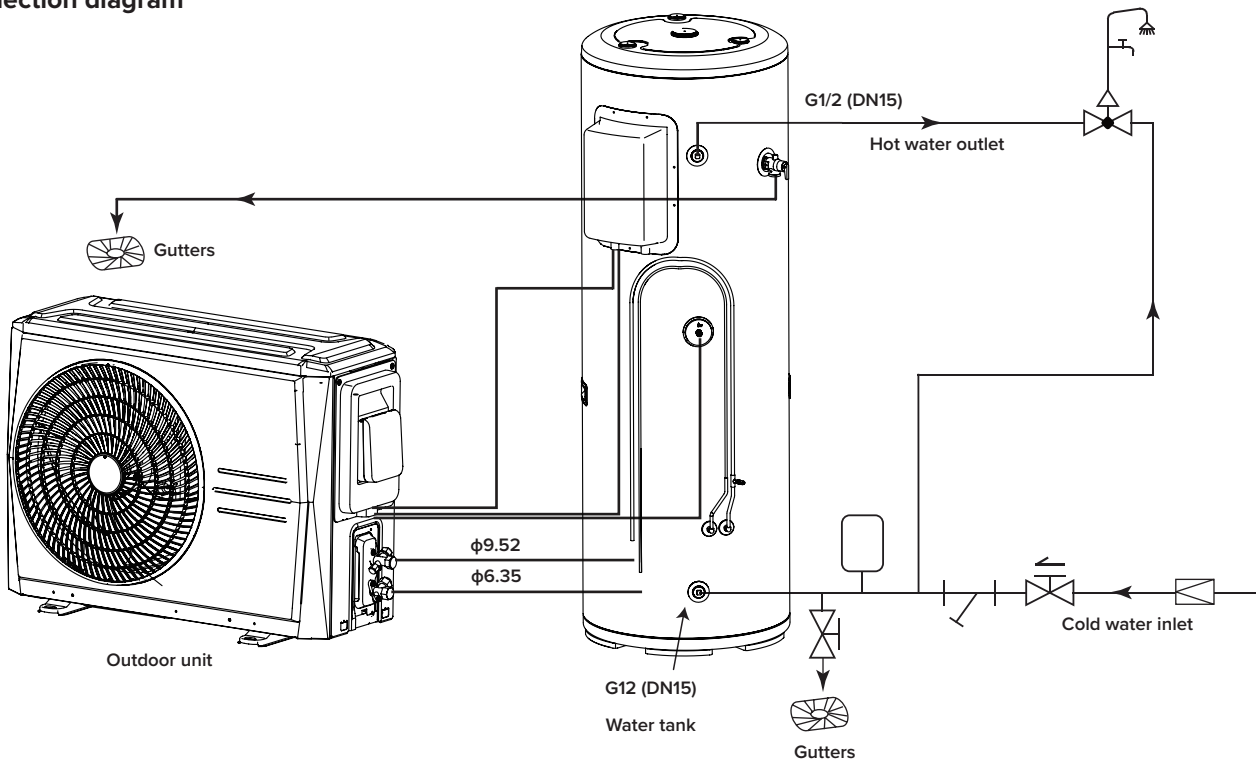

# Installation

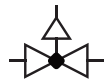
## Pipe connection

### Connection diagram



|   |   |  |   |
|---|---|--|---|
| Water use site  | One-way stop valve<br>(field supply)  | Water mixing valve<br>(field supply)   | Shut valve<br>(field supply)  |
|  |  |  |  |
| Gutter  | Expansion tank<br>(field supply, suggest to install)                                | Y-type filter (≥40 meshes)<br>(field supply)   | Pressure reducing valve<br>(field supply)   |
|  |  |  |  |

### NOTE

- The temperature of the water tank can be set between 52°C and 70°C.
- The minimum water inlet pressure should be no less than 0.15 MPa, and the maximum should not exceed 0.5 MPa.
- If the inlet water pressure is below 0.15 MPa, a pump must be installed at the water inlet.
- To ensure the safe usage of the tank, a pressure-reducing valve should be installed in the water inlet pipe if the water pressure exceeds 0.5 MPa.
- It is strongly recommended to use thread seal tape for sealing when connecting water pipes and valves.
- If the water temperature at the outlet of the mixing valve is higher than desired, please install a mixing valve at the end-user location.

# Installation

## PTR valve

- The valve body's unloading pressure is 850 kPa, unloading temperature is 99°C, and the opening energy value is 46 kW. For more details, refer to certificate No: WMK26608.
- The PTR valve should be tightened using a torque wrench set to 68 N.m. Apply sealant to the first three threads before installation. After installation, ensure the drain pipe outlet faces downward and that fewer than three threads are exposed on the PTR valve.
- The PTR valve must be correctly installed before filling the water tank.

### ⚠ CAUTION

Do not operate the valve handle quickly to avoid water hammer impact and potential damage to the valve.

- The PTR valve should be inspected every six months to ensure it is not restricted. Please be cautious of hot water from the valve. The drainage pipe should be well insulated to prevent the water inside from freezing in cold weather.

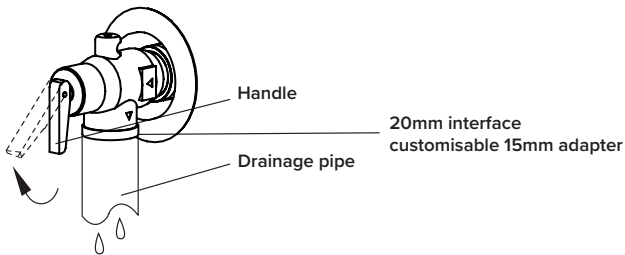

## Stop valve instruction

- In general, the shape of the stop valve and the names of each part are shown below.
- Effects of the stop valve:
  - Stops the system while the unit is operating.
  - When the water tank is connected to the outdoor unit, it evacuates and adds refrigerant through it.
  - Stops the system and recycles the refrigerant to the outdoor unit during maintenance.
- Operating the stop valve:
  - To open: dismantle the bonnet with a wrench and insert an allen key into the spool, turn the stop block anticlockwise, then tighten the bonnet.
  - To close: use a wrench to dismantle the bonnet and insert an allen key into the spool, turn the stop block clockwise, then tighten the bonnet.

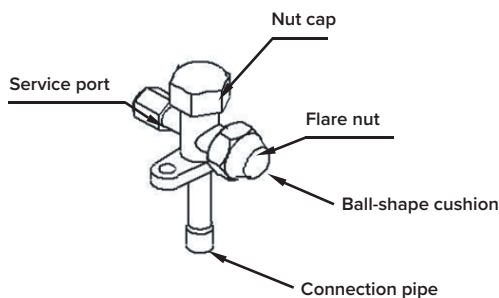

### ⚠ CAUTION

Before the water heater is operated, please ensure all stop valves are open. When operating the valves, ensure there are no open flames or sparks to prevent explosions or ignition.

## Connection length and height difference requirements for the outdoor unit and water tank pipe:

| Max. length (m) | Max. height difference (m) | Standard length (m) | Standard height difference (m) |
|-----------------|----------------------------|---------------------|--------------------------------|
| 20              | 10                         | 2                   | 0                              |

### 💡 NOTE

- Ensure that air, dust, or other impurities do not enter the pipe system during installation.
- Install the connecting pipe only after the indoor and outdoor units have been securely fixed.
- Keep the connecting pipe dry and ensure no moisture enters during installation.
- Wrap the connecting copper pipe with thermal insulation material.
- If the required length of piping exceeds the standard length of 2 meters, order the necessary actual length of extended piping, including refrigerant, from the supplier without needing additional refrigerant.

# Installation

## Quick connect couplings

- Quick connection sketch, please refer to diagram below

- ① Re-tighten the valve using a torque wrench. Tightening torque values: 20 Nm.
- ② Connect the quick connection to the stop valve using a torque wrench. Tightening torque values: 20 Nm.
- ③ Open the stop valve; for details (see previous stop valve instruction).

- Leak detection

- ① Re-tighten the valve using a torque wrench. Tightening torque values: 20 Nm.
- ② Connect the quick connection to the stop valve using a torque wrench. Tightening torque values: 20 Nm.
- ③ Open the stop valve; for details (see previous stop valve instruction).

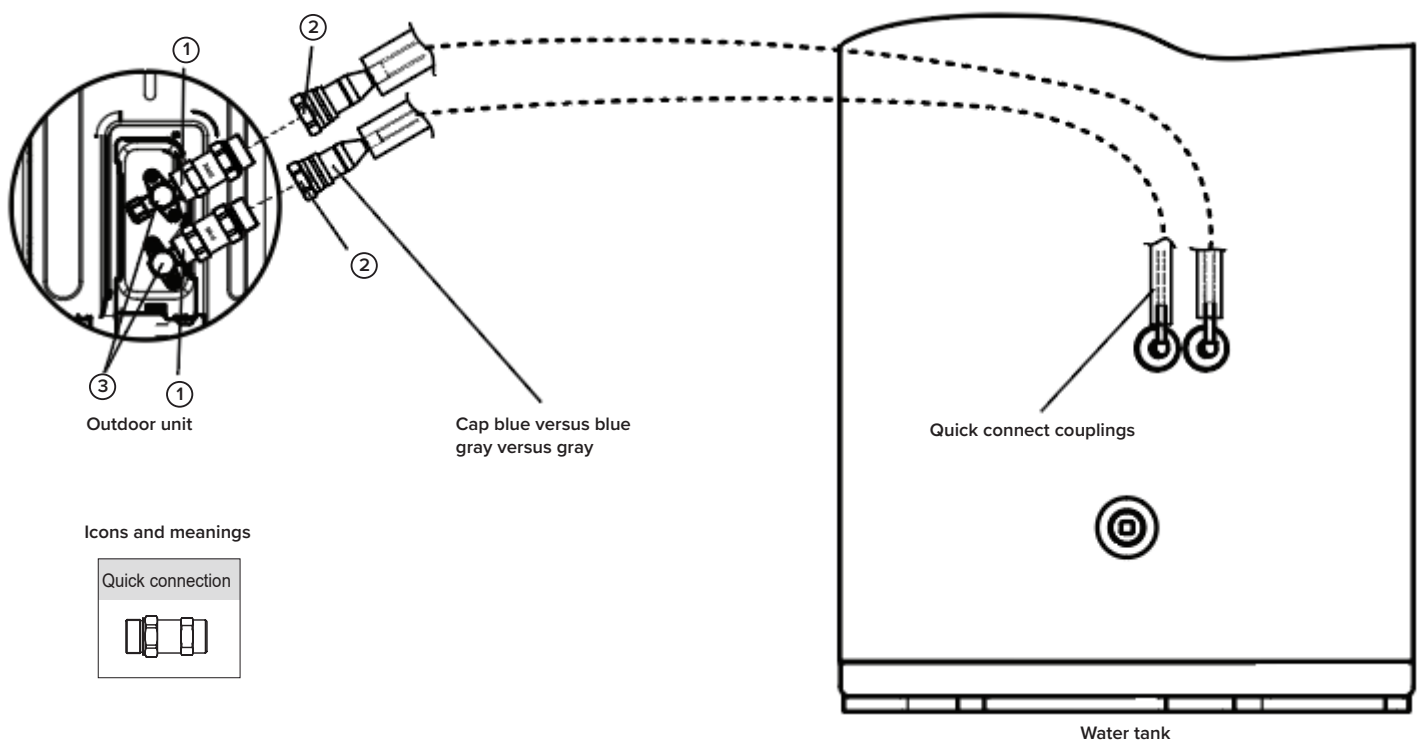

## Electrical connection

### CAUTION

- Ensure the heat pump uses a separate power supply with the correct rated voltage. If the voltage is unstable, please use a stabilised voltage supply.
- The external power supply for the heat pump must include ground wiring, which should connect to the ground wiring of both the indoor and outdoor units.
- Only qualified personnel should perform wiring tasks according to the circuit diagram.
- A leakage protector must be installed in accordance with the national standard for electrical appliances.
- An all-pole disconnection device, featuring at least 3 mm of separation at the contact points, must be installed.
- Arrange power supply cords and signal wires properly. Keep strong and weak current wires separate, and ensure they do not contact any connection pipes or valves.
- Install a power supply with a leakage protector in a waterproof location within the room.
- Avoid cross-connections between two wires; signal wires must be shielded.
- When laying power supply cords parallel to control wires, place the wires in the appropriate conduit and maintain adequate spacing between them.
- When choosing power supply cords, refer to the national standard and this manual. Power supplies used outdoors should not be lighter than NO.57 wire according to IEC 60245.
- If the power supply cord is damaged, it must be replaced by a professional to avoid hazard.
- Do not activate the power until all wiring has been thoroughly checked.

## Power supply cords

### Specification of power supply

| Item<br>Model | Power         | Min. wire dia. (mm <sup>2</sup> )<br>(metal pipe synthetic resin pipe wire) |             | Manual switch(A) |      | Leakage protector   | Max. E-heater Power(W) |
|---------------|---------------|---|-------------|------------------|------|---------------------|------------------------|
|               |               | Successive length ≤ 30 m  | Ground wire | Capacity         | Fuse |                     |                        |
| 200L/300L     | 220-240V~50Hz | 6.0   | 6.0         | 40               | 32   | 30 mA below 0.1 sec | 4 200                  |

### CAUTION

- Specifications for the power wires (outdoor unit power wire and power wire connected to the water tank): H07RN-F.
- Provide a dedicated power supply (do not use a shared power supply device).
- The wire diameter and successive length shown in the table are based on a voltage drop within 2%. If the successive length exceeds the value shown in the table, please select a wire diameter in accordance with relevant standards.

## Electrical connection

### Water tank temperature sensor installation

Connect the water tank temperature sensor wire connector to the outdoor unit T5U and T5L connector.

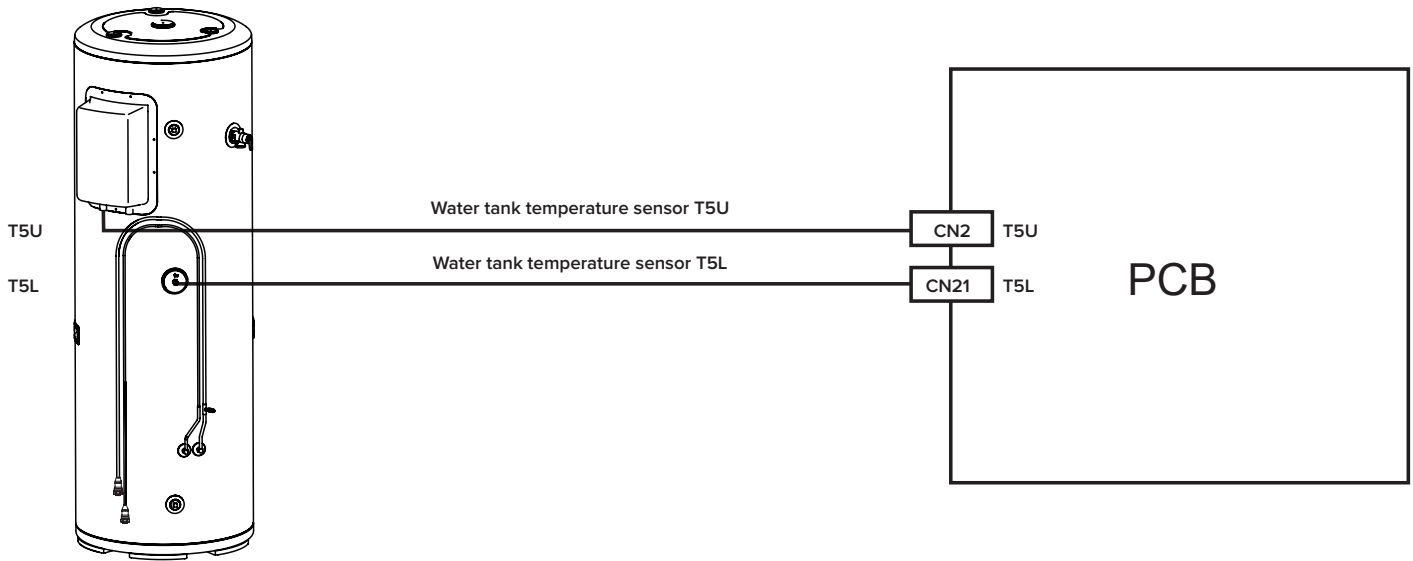

### Outdoor unit and AUX power connection

#### ⚠ CAUTION

- If the water tank is equipped with an electric auxiliary heater (AUX.) function, please follow the steps below to connect the electric auxiliary heating power cord:

1. Remove the protective cover of the electric control box on the right side of the outdoor unit.

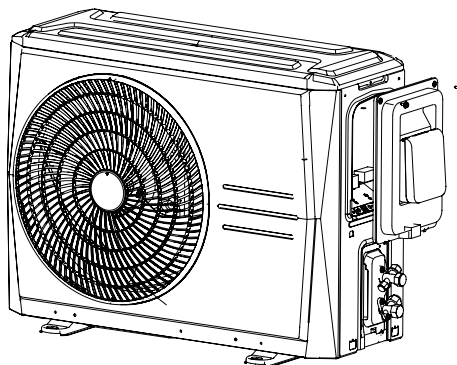

# Electrical connection

2. Connect the electric auxiliary heater power line on the water tank to the corresponding port on the terminal block.

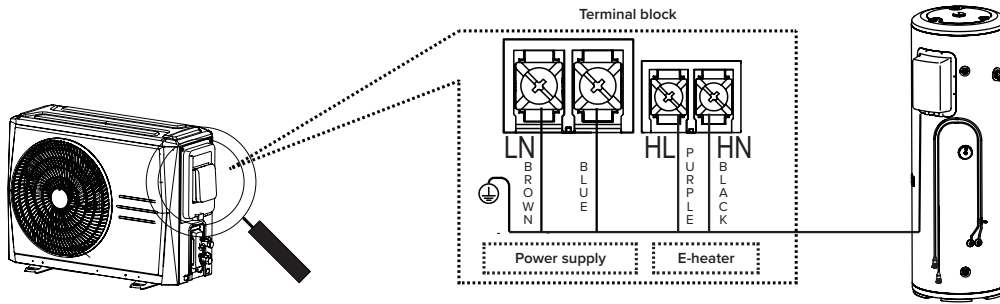

3. Power supply.

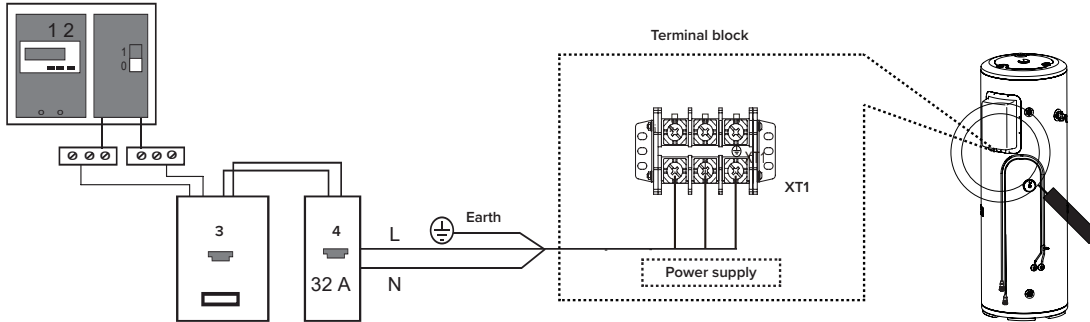

## ⚠ CAUTION

- A leakage protector must be installed on the power supply box outside the unit as shown in the figure above.
- The power supply equipped with a leakage protector must be installed indoors or in a location that meets waterproofing requirements.
- This unit can only be started if it is reliably grounded.

## Wiring diagram

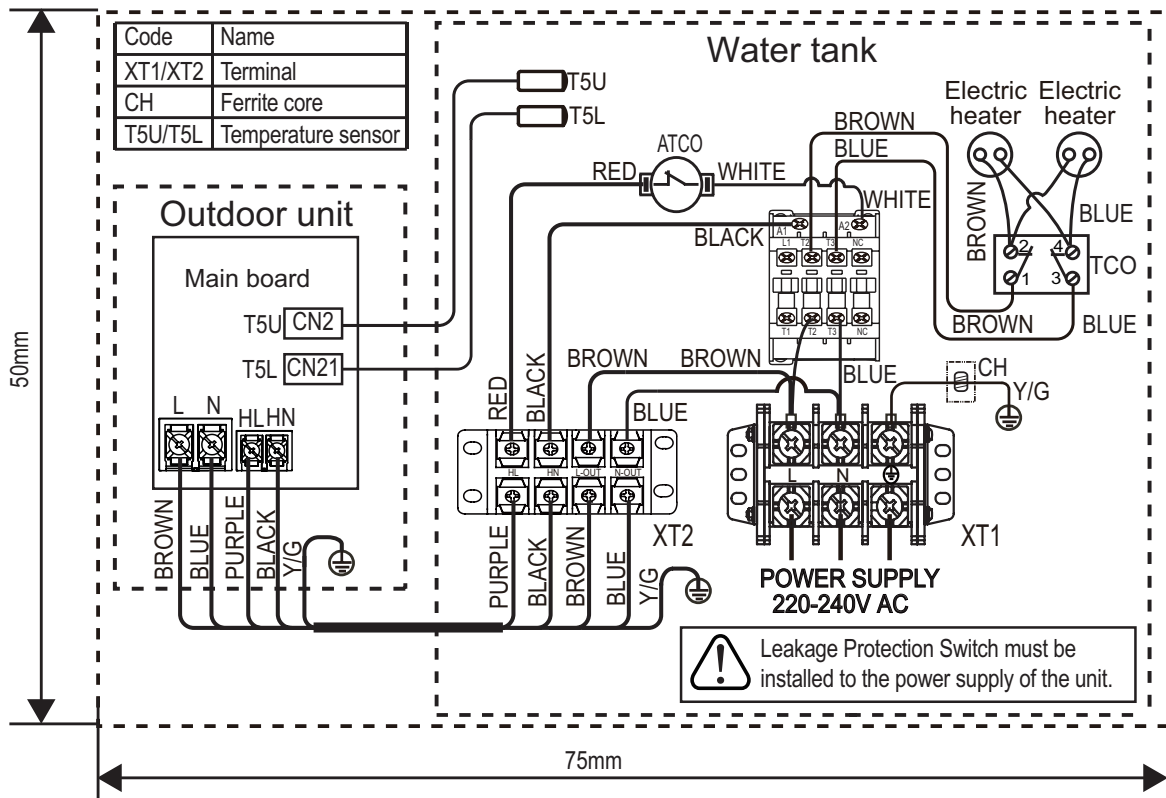







# Electrical connection

## Dip switch settings

### NOTE

• The picture shown is for reference only, actual product may vary.

 means 0,  means 1.

|      |   |   |  |
|------|---|---|--|
| S1-1 |    | 1 | Reserve  |
|      |   | 0 | Default  |
| S1-2 |    | 1 | Model2   |
|      |   | 0 | Model1   |
| S1-3 |    | 1 | Second setting parameters                      |
|      |   | 0 | First setting parameters                       |
| S2-1 |    | 1 | High temperature                               |
|      |   | 0 | Default temperature                            |
| S2-2 |   | 1 | User settings are valid in 24 hours by default |
|      |   | 0 | User settings are always valid by default      |
| S2-3 |  | 1 | High demand                                    |
|      |   | 0 | Normal demand                                  |

# Check











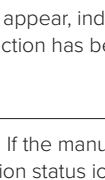











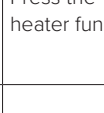

## NOTE

Before switching on the unit, please read the following recommendations:

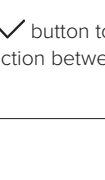
- Once the installation and parameter settings are complete, ensure all the unit's sheet metal is well covered.
- The unit should be maintained by professionals.

For the water tank with electric auxiliary heater, please check the quality of the electric auxiliary heater according to the method below before the long-term operation to avoid damage to the unit or personal injury.

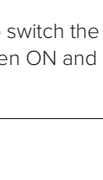
### Quality inspection of electric auxiliary heater

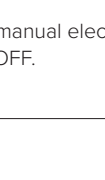
| Description   | Image   | Notice   |
|---|---|--|
| After the unit is powered on, press the power button  on the controller and the LED light will be lightened.   |    | The unit shall be installed according to the requirements of the corresponding specifications.<br>Before the unit is powered on, please ensure that the system operates in the environment where the water tank is full of water to prevent damage to the electric auxiliary heater.   |
| Long press the  button until the manual electric auxiliary heater (E-heater) function icon  appears, then press   buttons to select  icon (flashing slowly). |    | If the controller is locked and displays the icon  , long press  +  buttons to unlock the controller.<br>When the  icon disappears, it indicates that the controller is successfully unlocked. |
| Press  button again, and the icon  will appear, indicating that the manual electric auxiliary heater function has been turned on.   |    | Press the  button to switch the manual electric auxiliary heater function between ON and OFF.   |
| Press  button to return to main interface. If the manual E-heater function icon and E-heater operation status icon are displayed, it means that the manual E-heater function has been turned on, and the E-heater is nonoperational status. If not, please check whether steps 1 to 4 are correct.   |    |  |
| After the manual E-heater function is turned on, wait for 5min to make the E-heater operate stably in the environment with water, check whether the leakage protection switch trips. If there is a trip, immediately cut off the power and notify the professional maintenance personnel.   |   | In this case, it is usually need to replace the electric heater.   |
| If no tripping occurs, please turn off the manual E-heater function after unlocking the controller. Then long press the  button to enter the E-heater function interface.  |  |  |
| After entering the E-heater function interface, press  button again to cancel the manual E-heater function, and the icon display will change from  to  .   |  |  |
| Press the  button to return to the main interface, and you can find that the manual E-heater function icon and the E-heater operation status icon are disappeared, indicating that the manual E-heater function has been closed.   |  |  |

### System parameters check

If the unit fails or is in protection mode, the controller will display the corresponding code. If multiple failures or protections occur, the failure protection order will be displayed. When checking the controller, more parameters can be obtained.

# Service and maintenance

## Checks to the area

Prior to beginning work on systems containing flammable refrigerants, safety checks are necessary to ensure that the risk of ignition is minimised. For repair to the refrigerating system, the following precautions shall be complied with prior to conducting work on the system.

## Work procedure

Works shall be undertaken under a controlled procedure so as to minimise the risk of a flammable gas or vapour being present while the work is being performed.

## General work area

All maintenance staff and others working in the local area shall be instructed on the nature of work being carried out. Work in confined spaces shall be avoided. The area around the work space shall be sectioned off. Ensure that the conditions within the area have been made safe by control of flammable material.

## Checking for presence of refrigerant

The area shall be checked with an appropriate refrigerant detector prior to and during work, to ensure the technician is aware of potentially flammable atmospheres. Ensure that the leak detection equipment being used is suitable for use with flammable refrigerants, i.e. no sparking, adequately sealed or intrinsically safe.

## Presence of fire extinguisher

If any hot work is to be conducted on the refrigeration equipment or any associated parts, appropriate fire extinguishing equipment shall be available to hand. Have a dry power or CO<sub>2</sub> fire extinguisher adjacent to the charging area.

## No ignition sources

No person carrying out work in relation to a refrigeration system which involves exposing any pipe work that contains or has contained flammable refrigerant shall use any sources of ignition in such a manner that it may lead to the risk of fire or explosion.

All possible ignition sources, including cigarette smoking, should be kept sufficiently far away from the site of installation, repairing, removing and disposal, during which flammable refrigerant can possibly be released to the surrounding space. Prior to work taking place, the area around the equipment is to be surveyed to make sure that there are no flammable hazards or ignition risks. NO SMOKING signs shall be displayed.

## Ventilated area

Ensure that the area is in the open or that it is adequately ventilated before breaking into the system or conducting any hot work.

A degree of ventilation shall continue during the period that the work is carried out. The ventilation should safely disperse any released refrigerant and preferably expel it externally into the atmosphere.

## Checks to the refrigeration equipment

Where electrical components are being changed, they shall be fit for the purpose and to the correct specification. At all times the manufacturer's maintenance and service guidelines shall be followed. If in doubt consult the manufacturer's technical department for assistance. The following checks shall be applied to installations using flammable refrigerants.

- The charge size is in accordance with the room size within which the refrigerant containing parts are installed.
- The ventilation machinery and outlets are operating adequately and are not obstructed.
- If an indirect refrigerating circuit is being used, the secondary circuits shall be checked for the presence of refrigerant; marking to the equipment continues to be visible and legible.
- Marking and signs that are illegible shall be corrected.

- Refrigeration pipe or components are installed in a position where they are unlikely to be exposed to any substance which may corrode refrigerant containing components, unless the components are constructed of materials which are inherently resistant to being corroded or are suitably protected against being so corroded.

## Checks to electrical devices

Repair and maintenance to electrical components shall include initial safety checks and component inspection procedures. If a fault exists that could compromise safety, then no electrical supply shall be connected to the circuit until it is satisfactorily dealt with. If the fault cannot be corrected immediately but it is necessary to continue operation, and adequate temporary solution shall be used. This shall be reported to the owner of the equipment so all parties are advised.

Initial safety checks shall include:

- That capacitors are discharged: this shall be done in a safe manner to avoid possibility of sparking.
- That there no live electrical components and wiring are exposed while charging, recovering or purging the system.
- That there is continuity of earth bonding.

## Repairs to sealed components

a) During repairs to sealed components, all electrical supplies shall be disconnected from the equipment being worked upon prior to any removal of sealed covers, etc. If it is absolutely necessary to have an electrical supply to equipment during servicing, then a permanently operating form of leak detection shall be located at the most critical point to warn of a potentially hazardous situation.

b) Particular attention shall be paid to the following to ensure that by working on electrical components, the casing is not altered in such a way that the level of protection is affected. This shall include damage to cables, excessive number of connections, terminals not made to original specification, damage to seals, incorrect fitting of glands, etc.

Ensure that apparatus is mounted securely.

Ensure that seals or sealing materials have not degraded such that they no longer serve the purpose of preventing the ingress of flammable atmospheres. Replacement parts shall be in accordance with the manufacturer's specifications.

The use of silicon sealant may inhibit the effectiveness of some types of leak detection equipment. Intrinsically safe components do not have to be isolated prior to working on them.

## Repair to intrinsically safe components

Do not apply any permanent inductive or capacitance loads to the circuit without ensuring that this will not exceed the permissible voltage and current permitted for the equipment in use. Intrinsically safe components are the only types that can be worked on while live in the presence of a flammable atmosphere. The test apparatus shall be at the correct rating. Replace components only with parts specified by the manufacturer. Other parts may result in the ignition of refrigerant in the atmosphere from a leak.

## Cabling

Check that cabling will not be subject to wear, corrosion, excessive pressure, vibration, sharp edges or any other adverse environmental effects. The check shall also take into account the effects of aging or continual vibration from sources such as compressors or fans.

## Detection of flammable refrigerants

Under no circumstances shall potential sources of ignition be used in the searching for or detection of refrigerant leaks. A halide torch (or any other detector using a naked flame) shall not be used.

## Leak detection methods

The following leak detection methods are deemed acceptable for systems containing flammable refrigerants. Electronic leak detectors shall be used to detect flammable refrigerants, but the sensitivity may not be adequate, or may need re-calibration. (Detection equipment shall be calibrated in a refrigerant-free area.) Ensure that the detector is not a potential source of ignition and is suitable for the refrigerant. Leak detection equipment shall be set at a percentage of the LFL of the refrigerant and shall be calibrated to the refrigerant employed and the appropriate percentage of gas (25 % maximum) is confirmed. Leak detection fluids are suitable for use with most refrigerants but the use of detergents containing chlorine shall be avoided as the chlorine may react with

# Service and maintenance

The refrigerant can corrode the copper pipe-work. If a leak is suspected, all naked flames shall be removed or extinguished. If a leakage of refrigerant is found which requires brazing, all of the refrigerant shall be recovered from the system, or isolated (by means of shut off valves) in a part of the system remote from the leak. Oxygen free nitrogen (OFN) shall then be purged through the system both before and during the brazing process.

## Removal and evacuation

When breaking into the refrigerant circuit to make repairs or for any other purpose conventional procedures shall be used, however, it is important that best practice is followed since flammability is a consideration. The following procedure shall be adhered to:

- Remove refrigerant;
- Purge the circuit with inert gas;
- Evacuate;
- Purge again with inert gas;
- Open the circuit by cutting or brazing.

The refrigerant charge shall be recovered into the correct recovery cylinders. The system shall be flushed with OFN to render the unit safe. This process may need to be repeated several times.

Compressed air or oxygen shall not be used for this task. Flushing shall be achieved by breaking the vacuum in the system with OFN and continuing to fill until the working pressure is achieved, then venting to atmosphere, and finally pulling down to a vacuum. This process shall be repeated until no refrigerant is within the system.

When the final OFN charge is used, the system shall be vented down to atmospheric pressure to enable work to take place. This operation is absolutely vital if brazing operations on the pipe-work are to take place.

Ensure that the outlet for the vacuum pump is not closed to any ignition sources and there is ventilation available.

## Charging procedures

In addition to conventional charging procedures, the following requirements shall be followed:

- Ensure that contamination of different refrigerants does not occur when using charging equipment. Hoses or lines shall be as short as possible to minimize the amount of refrigerant contained in them.
- Cylinders shall be kept upright.
- Ensure that the refrigeration system is earthed prior to charging the system with refrigerant.
- Label the system when charging is complete (if not already).
- Extreme care shall be taken not to overfill the refrigeration system.
- Prior to recharging the system it shall be pressure tested with OFN. The system shall be leak tested on completion of charging but prior to commissioning. A follow up leak test shall be carried out prior to leaving the site.

## Decommissioning

Before carrying out this procedure, it is essential that the technician is completely familiar with the equipment and all its detail. It is recommended good practice that all refrigerants are recovered safely. Prior to the task being carried out, an oil and refrigerant sample shall be taken.

In case analysis is required prior to re-use of reclaimed refrigerant. It is essential that electrical power is available before the task is commenced.

- a) Become familiar with the equipment and its operation.
- b) Isolate system electrically
- c) Before attempting the procedure ensure that:
  - Mechanical handling equipment is available, if required, for handling refrigerant cylinders.
  - All personal protective equipment is available and being used correctly.
  - The recovery process is supervised at all times by a competent person.
  - Recovery equipment and cylinders conform to the appropriate standards.
- d) Pump down refrigerant system, if possible.
- e) If a vacuum is not possible, make a manifold so that refrigerant can be removed from various parts of the system.

f) Make sure that cylinder is situated on the scales before recovery takes place.

g) Start the recovery machine and operate in accordance with manufacturer's instructions.

h) Do not overfill cylinders. (No more than 80 % volume liquid charge).

i) Do not exceed the maximum working pressure of the cylinder, even temporarily.

j) When the cylinders have been filled correctly and the process completed, make sure that the cylinders and the equipment are removed from site promptly and all isolation valves on the equipment are closed off.

k) Recovered refrigerant shall not be charged into another refrigeration system unless it has been cleaned and checked.

## Labeling

Equipment shall be labeled stating that it has been de-commissioned and emptied of refrigerant. The label shall be dated and signed. Ensure that there are labels on the equipment stating the equipment contains flammable refrigerant.

## Recovery

When removing refrigerant from a system, either for service or de-commissioning, it is recommended good practice that all refrigerants are removed safely.

When transferring refrigerant into cylinders, ensure that only appropriate refrigerant recovery cylinders are employed. Ensure that the correct numbers of cylinders for holding the total system charge are available. All cylinders to be used are designated for the recovered refrigerant and labeled for that refrigerant (i.e. special cylinders for the recovery of refrigerant). Cylinders shall be complete with pressure relief valve and associated shut-off valves in good working order.

Empty recovery cylinders are evacuated and, if possible, cooled before recovery occurs.

The recovery equipment shall be in good working order with a set of instructions concerning the equipment that is at hand and shall be suitable for the recovery of flammable refrigerants. In addition, a set of calibrated weighing scales shall be available and in good working order.

Hoses shall be complete with leak-free disconnect couplings and in good condition. Before using the recovery machine, check that it is in satisfactory working order, has been properly maintained and that any associated electrical components are sealed to prevent ignition in the event of a refrigerant release. Consult manufacturer if in doubt.

The recovered refrigerant shall be returned to the refrigerant supplier in the correct recovery cylinder, and the relevant Waste Transfer Note arranged. Do not mix refrigerants in recovery units and especially not in cylinders.

If compressors or compressor oils are to be removed, ensure that they have been evacuated to an acceptable level to make certain that flammable refrigerant does not remain within the lubricant. The evacuation process shall be carried out prior to returning the compressor to the suppliers. Only electric heating to the compressor body shall be employed to accelerate this process. When oil is drained from a system, it shall be carried out safely.

## Transportation, marking and storage for units

Transport of equipment containing flammable refrigerants compliance with the transport regulations.

Marking of equipment using signs compliance with local regulations.

Disposal of equipment using flammable refrigerants compliance with national regulations.

Storage of equipment/appliances.

The storage of equipment should be in accordance with the manufacturer's instructions.

Storage of packed (unsold) equipment .

Storage package protection should be constructed such that mechanical damage to the equipment inside the package will not cause a leak of the refrigerant charge.

The maximum number of pieces of equipment permitted to be stored together will be determined by local regulations.

# Service and maintenance

## Confirmation before running

- 1) Make sure whether ground wire is broken or fall off.
- 2) Power on the machine after all connections are qualified.

## Troubleshooting when abnormal situation happens

Before asking for serving or repairing, check the following points:

- Non-mechanical malfunction
- 1) Water oozes from safety valve pressure relief opening
    - When water heating, cold water will expand when heated, water oozing is normal. Do not block it for safety consideration.
    - If a large amount of water flows, it means safety valve is invalid. Stop using and replace safety valve.
  - 2) Long period for heating a tank of water
    - In winter, water heating efficiency will decrease because of low ambient temperature (about 0°C). It will take a longer time for water heating.
    - If customer needs to use hot water, please start the unit in advance.
- Need to check
- 1) Automatically start or stop
    - Whether we set timer wrongly.
  - 2) When not working
    - Check whether powering on.
    - Whether manual switch is on.
    - Whether fuse blows.
    - Whether start the protection device (indicator lights).
    - Whether it is not the time of timer on (operation lamp lights.)
  - 3) If heating effect is not good
    - Whether air outlet and inlet has been blocked.

### CAUTION

- If the following situation happens, please stop running and cut off power supply manually and contact with the dealer or service center.
    - ON/OFF operation is ineffective.
    - Fuse or RCCB trips frequently.
  - Before leave unused for a long time, please complete the following items:
    - Drain water from tank and pipes, close all valve bodies.
- After leave unused for a long time, please check the following items:
- Check air inlet and outlet of the unit to see whether they are blocked. Clean immediately when they are blocked.
  - Check whether water pipes, valves have been damages or blocked. Whether there's water leakage in joints, replace them when water leaks.
  - It is suggest to inspect anode protection material every half year. If it has been exhausted, please replace it with a new one

## Important information for the used refrigerant

This product has flammable gas, it is forbidden to install in an enclosed space.

Refrigerant type: R290; Value of GWP: 3  
GWP=Global Warming Potential

| Factory charge |                                   |
|----------------|-----------------------------------|
| Refrigerant/kg | Tonnes CO <sub>2</sub> equivalent |
| 0.47           | 0.00141                           |

### WARNING

Frequency of Refrigerant Leak Checks:

1. For equipment that contains fluorinated greenhouse gases in quantities of 5 tonnes of CO<sub>2</sub> equivalent or more, but of less than 50 tonnes of CO<sub>2</sub> equipment, at least every 12 months, or where a leakage detection system is installed, at least every 24 months.
2. For equipment that contains fluorinated greenhouse gases in quantities of 50 tonnes of CO<sub>2</sub> equivalent or more, but of less than 500 tonnes of CO<sub>2</sub> equipment, at least every six months, or where a leakage detection system is installed, at least every 12 months.
3. For equipment that contains fluorinated greenhouse gases in quantities of 500 tonnes of CO<sub>2</sub> equivalent or more, at least every three months, or where a leakage detection system is installed, at least every six months.
4. Non-hermetically sealed equipment charged with fluorinated greenhouse gases shall only be sold to the end user where evidence is provide that the installation is to be carried out by an undertaking certified person.
5. Only certificated person is allowed to do installation, operation and maintenance.

## Water quality limitations

### NOTE

If the water quality does not meet the requirements in the table below, please contact the supplier for advice.

| PH Value     | Total Hardness | Electrical Conductivity |
|--------------|----------------|-------------------------|
| 6.5-8.0      | 50 ppm         | < 200 μS/cm(25°C)       |
| Sulphate Ion | Silicon        | Iron Content            |
| < 50 ppm     | < 30 ppm       | < 0.3 ppm               |
| Sulfide Ion  | Chloride Ion   | Ammonia Ion             |
| None         | < 50 ppm       | None                    |
| Sodium Ion   | Calcium Ion    | -                       |
| None         | < 50 ppm       | -                       |

# Service and maintenance

## Maintenance

### About refrigerant recovery

If the water tank needs to be replaced, the refrigerant needs to be recycled to the unit. The operation method for refrigerant recovery is as follows:

At first, when the controller of the unit is turned on, activate the refrigerant recovery function according to the operating instructions of the controller.

After blowing out hot air from the unit, then shut the liquid side refrigerant stop valve (the smaller one) of the unit.

After the temperature of the air blown out is close to ambient temperature, shut the gas side refrigerant stop valve (the bigger one), then cut off the power, and the refrigerant recovery is completed.

### About vacuuming

Vacuum drying should be performed in order to remove moisture and non-condensable gases from the system. Removing moisture prevents ice formation and oxidization of copper piping or other internal components. The presence of ice particles in the system would cause abnormal operation, whilst particles of oxidized copper can cause compressor damage. The presence of non-condensable gases in the system would lead to pressure fluctuations and poor heat exchange performance.

### ⚠ CAUTION

- When installing for the first time, there is no need to vacuum because the water tank and connecting pipes (included in the accompanying accessories) are already pre filled with refrigerant.
- Vacuuming is needed after having finished field maintenance of refrigerant system without disconnecting outdoor unit, water tank and connection pipes.
- When vacuuming after maintenance, make sure that there are no open flames or sparks to prevent explosion or ignition.

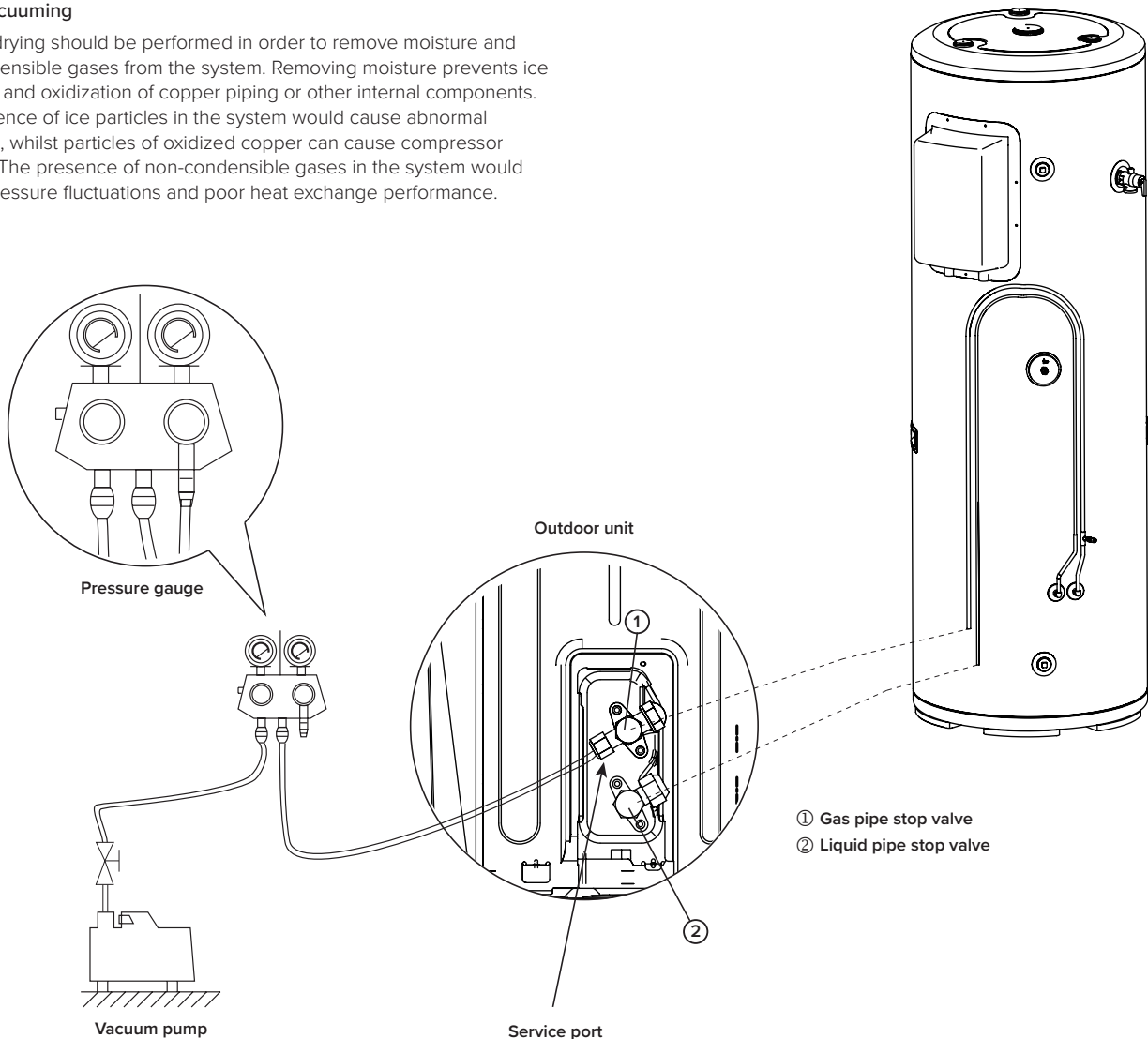

## Service and maintenance

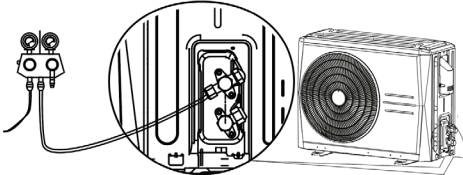
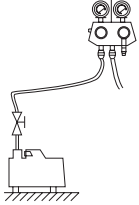
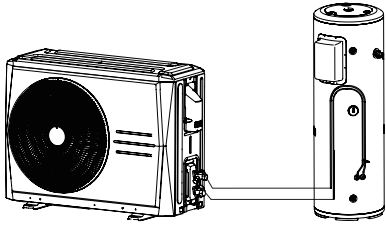
|  |  |   |
|--|--|---|
| <p>Connect the (low pressure side) hose of a pressure gauge to the outdoor unit gas pipe stop valve.</p>   |  | <p>Before performing vacuum drying, make sure that all the outdoor unit stop valves are firmly closed.</p>  |
| <p>Connect the hose to the vacuum pump.</p>  |   |   |
| <p>Connect the outdoor unit stop valve to water tank connection.</p>   |   | <ol style="list-style-type: none"> <li>1. Mixing of pump lubricant with compressor oil could cause compressor malfunction and a one-way valve should therefore be used to prevent vacuum pump lubricant seeping into the piping system.</li> <li>2. Using a vacuum pump with a discharge in excess of 4 L/s and a precision level of 0.02 mmHg is recommended.</li> </ol> |
| <p>Start the vacuum pump and then open the pressure gauge valves to start vacuum the system.</p>   |  |   |
| <p>After 15-20 minutes, close the pressure gauge valves.</p>   |  |   |
| <p>After a further 5 to 10 minutes check the pressure gauge. If the gauge is no change, then vacuum drying is OK.<br/>If the gauge has returned to zero, check for leakages in the refrigerant piping, then fix them.</p>  |  |   |
| <p>After leakages are fixed, re-open the pressure gauge valves and continue vacuum drying for at least 20 minutes and until a pressure difference of 756 mmHg or more has been achieved.<br/>Once the pressure difference of at least 756 mmHg has been achieved, continue vacuum drying for 20 minutes.</p> |  |   |
| <p>Close the pressure gauge valves and then stop the vacuum pump.</p>  |  |   |
| <p>After 1 hour, check the pressure gauge. If the pressure in the piping has not increased, the procedure is finished. If the pressure has increased, check for leakages.</p>  |  | <p>After vacuum drying, keep the hoses connected to the pressure gauge and to the outdoor unit stop valves, in preparation for refrigerant charging.</p>  |

### Refrigerant charge

- If there is no refrigerant in the system after maintenance, it is necessary to recharge the refrigerant after completing the vacuum pumping operation.
- The weight of refrigerant recharge should be calculated according to the following rules:  
If the pipe length is less than 2 meters, the recharge weight of refrigerant 470 g.  
If the pipe length is more than 2 meters, adding additional refrigerant charge is necessary, and the rule is 10 g/m for the additional pipe length.

## After sales service

If your hot water heater can not operate normally, turn off the unit and cut off the power supply at immediately.

Contact your service center or technical department.

[emerald.com.au/contactform](https://emerald.com.au/contactform)

**Emerald Energy Pty Ltd**

ABN 86 632 172 368

L2, 12a Rodborough Road Frenchs Forest NSW 2086